



**INDUSTRIAL  
CONTROL DIRECT**

A B&D Industrial Company

**IMO**

*The World's Finest*

# iSmart

## Intelligent Relay (v3)

## Hardware Manual



Smart Control **Smart Choice**

## PREFACE

This manual explains how to use all models types of the *iSmart* Intelligent Relay.



### WARRANTY AND LIMITATION OF LIABILITY

IMO Precision Controls Ltd. warrants to the original purchaser that the *iSmart* module is free from defects in material and workmanship under normal use and service. The obligation of IMO under this warranty shall be limited to the repair or exchange of any part or parts which may prove defective under normal use and service within three (3) years from the date of purchase, such defect to be disclosed to the satisfaction of IMO after examination by IMO of the allegedly defective part or parts. THIS WARRANTY IS EXPRESSLY IN LIEU OF ALL OTHER WARRANTIES EXPRESSED OR IMPLIED INCLUDING THE WARRANTIES OF MERCHANTABILITY AND FITNESS FOR USE AND OF ALL OTHER OBLIGATIONS OR LIABILITIES AND IMO NEITHER ASSUMES, NOR AUTHORIZES ANY OTHER PERSON TO ASSUME FOR IMO, ANY OTHER LIABILITY IN CONNECTION WITH THE SALE OF THIS *iSmart* module. THIS WARRANTY SHALL NOT APPLY TO THIS *iSmart* module OR ANY PART THEREOF WHICH HAS BEEN SUBJECT TO ACCIDENT, NEGLIGENCE, ALTERATION, ABUSE, OR MISUSE. IMO MAKES NO WARRANTY WHATSOEVER IN RESPECT TO ACCESSORIES OR PARTS NOT SUPPLIED BY IMO. THE TERM "ORIGINAL PURCHASER", AS USED IN THIS WARRANTY, SHALL BE DEEMED TO MEAN THAT PERSON FOR WHOM THE *iSmart* module IS ORIGINALLY INSTALLED. In no event, whether as a result of breach of contract, warranty, tort (including negligence) or otherwise, shall or its suppliers be liable of any special, consequential, incidental or penal damages including, but not limited to, loss of profit or revenues, loss of use of the products or any associated equipment, damage to associated equipment, cost of capital, cost of substitute products, facilities, services or replacement power, down time costs, or claims of original purchaser's customers for such damages.

**To obtain warranty service, return the product to your distributor with a description of the problem, proof of purchase, post paid, insured and in a suitable package.**

### ABOUT PROGRAMMING EXAMPLES

Any example programs and program segments in this manual or provided on accompanying diskettes are included solely for illustrative purposes. Due to the many variables and requirements associated with any particular installation, IMO Precision Controls Ltd. cannot assume responsibility or liability for actual use based on the examples and diagrams. It is the sole responsibility of the system designer utilizing the *iSmart* module to appropriately design the end system, to appropriately integrate the *iSmart* module and to make safety provisions for the end equipment as is usual and customary in industrial applications as defined in any codes or standards which apply.

**Note: All programming examples shown in this manual or in tutorials are for illustrative purposes only. Proper machine operation is the sole responsibility of the system integrator.**

<b>SUMMARY OF CHANGES .....</b>	<b>6</b>
<b>CHAPTER 1: GETTING STARTED .....</b>	<b>7</b>
EXAMINATION BEFORE INSTALLATION .....	8
ENVIRONMENTAL PRECAUTIONS .....	8
SMT MODEL IDENTIFICATION.....	9
<b>QUICK START SETUP.....</b>	<b>10</b>
INSTALL SMT CLIENT SOFTWARE.....	10
CONNECT POWER TO iSMART RELAY .....	10
CONNECT PROGRAMMING CABLE.....	11
ESTABLISH COMMUNICATION .....	11
WRITE SIMPLE PROGRAM .....	12
<b>CHAPTER 2: INSTALLATION.....</b>	<b>15</b>
GENERAL SPECIFICATIONS .....	15
PRODUCT SPECIFICATIONS .....	18
MOUNTING .....	19
WIRING .....	21
B TYPE INDICATOR LIGHT .....	23
<b>CHAPTER 3: PROGRAM TOOLS.....</b>	<b>24</b>
PC PROGRAMMING SOFTWARE “SMT CLIENT” .....	24
<i>Installing the Software</i> .....	24
<i>Connecting the Software</i> .....	25
<i>Start Screen</i> .....	25
<i>Ladder Logic Programming Environment</i> .....	26
<i>Programming</i> .....	28
<i>Simulation Mode</i> .....	29
<i>Establish Communication</i> .....	30
<i>Writing a Program to the iSmart</i> .....	31
<i>Operation menu</i> .....	31
<i>Online Monitoring/Editing</i> .....	32
<i>HMI/TEXT</i> .....	33
<i>Program Documentation</i> .....	36
<i>AQ Set</i> ... ..	37
MEMORY CARTRIDGE (SOLD SEPARATELY).....	39
LCD DISPLAY AND KEYPAD .....	40
<i>Keypad</i> .....	40
<i>Original Screen</i> .....	40
<i>LCD Display Main Menu</i> .....	43
<b>CHAPTER 4: RELAY LADDER LOGIC PROGRAMMING .....</b>	<b>52</b>
COMMON MEMORY TYPES.....	52
SPECIALTY MEMORY TYPES.....	55
OUTPUT INSTRUCTIONS.....	57
ANALOGUE MEMORY TYPE.....	58
TIMER INSTRUCTION .....	59
COUNTER INSTRUCTIONS .....	67
REAL TIME CLOCK (RTC) INSTRUCTIONS.....	77
COMPARATOR INSTRUCTIONS .....	84
HMI DISPLAY INSTRUCTIONS .....	87
PWM OUTPUT INSTRUCTION (DC TRANSISTOR OUTPUT MODELS ONLY) .....	90
DATA LINK/REMOTE I/O INSTRUCTION (SMT-CDXX MODEL ONLY) .....	93

SHIFT (SHIFT OUTPUT) .....	96
AQ (ANALOGUE OUTPUT) .....	97
AS (ADD-SUBTRACT) .....	99
MD (MUL-DIV) .....	100
PID (PROPORTION- INTEGRAL- DIFFERENTIAL) .....	101
MX (MULTIPLEXER) .....	102
AR (ANALOGUE-RAMP).....	103
DR (DATA REGISTER) .....	105
MU (MODBUS) (ONLY CD TYPE MODEL) .....	107
<b>CHAPTER 5: FUNCTION BLOCK DIAGRAM PROGRAMMING .....</b>	<b>110</b>
COIL BLOCK INSTRUCTION.....	110
<i>HMI</i> .....	111
<i>PWM function block (only transistor output version)</i> .....	111
<i>Data Link function block</i> .....	112
<i>SHIFT function block</i> .....	112
LOGIC BLOCK INSTRUCTIONS.....	113
<i>AND Logic Diagram</i> .....	114
<i>AND (EDGE) Logic Diagram</i> .....	114
<i>NAND Logic Diagram</i> .....	114
<i>NAND (EDGE) Logic Diagram</i> .....	114
<i>OR Logic Diagram</i> .....	115
<i>OR Logic Diagram</i> .....	116
<i>XOR Logic Diagram</i> .....	116
<i>SR Logic Diagram</i> .....	116
<i>NOT Logic Diagram</i> .....	116
<i>Pulse Logic Diagram</i> .....	118
<i>BOOLEAN Logic Diagram</i> .....	118
FUNCTION BLOCK.....	119
<i>Timer Function Block</i> .....	120
<i>Common Counter function block</i> .....	122
<i>High Speed Counter Function Block</i> .....	123
<i>RTC Comparator Function Block</i> .....	125
<i>Analogue Comparator Function Block</i> .....	126
<i>AS (ADD-SUB) function block</i> .....	127
<i>MD (MUL-DIV) function block</i> .....	127
<i>PID (Proportion- Integral- Differential) function block</i> .....	128
<i>MX (Multiplexer) function block</i> .....	128
<i>AR (Analogue-Ramp) function block</i> .....	128
<i>DR (Data-Register) function block</i> .....	128
<i>MU (MODBUS) function block</i> .....	129
<b>CHAPTER 6: HARDWARE SPECIFICATION .....</b>	<b>131</b>
NORMAL SPECIFICATION.....	131
PRODUCT SPECIFICATIONS .....	132
POWER SPECIFICATIONS.....	133
<i>Standard Model Specifications</i> .....	133
<i>12V DC Model Specifications</i> .....	134
<i>24V AC model Specifications</i> .....	134
<i>Power circuitry diagram</i> .....	135
INPUT SPECIFICATIONS .....	136
<i>100~240V AC model</i> .....	136
<i>24V AC model</i> .....	136
<i>24V DC, 12I/O model</i> .....	137
<i>24V DC, 20I/O model</i> .....	138

OUTPUT SPECIFICATIONS .....	139
OUTPUT PORT WIRING NOTICE.....	139
<i>Light Load</i> .....	139
<i>Inductance Load</i> .....	140
<i>Life of relay</i> .....	140
DIMENSIONS OF SMT .....	141
<b>CHAPTER 7: 20 POINTS C TYPE MODELS INSTRUCTION .....</b>	<b>142</b>
FUNCTION SUMMARY: .....	142
DETAIL INSTRUCTION.....	142
<i>Communication parameter</i> .....	142
<i>Remote IO function</i> .....	143
<i>IO Link Function</i> .....	145
<i>Modbus RTU master</i> .....	147
<i>Slave via Modbus RTU Protocol</i> .....	149
SMT MODBUS PROTOCOL .....	150
<i>Useful Modbus References</i> .....	151
<b>CHAPTER 8: EXPANSION MODULE .....</b>	<b>153</b>
SUMMARY: .....	153
DIGITAL IO MODULE.....	155
ANALOGUE MODULE .....	161
COMMUNICATION MODULE .....	164
<i>ModBus module</i> .....	164
<i>DeviceNet COMM. Module</i> .....	167
<i>Profibus</i> .....	170
<b>APPENDIX: KEYPAD PROGRAMMING .....</b>	<b>173</b>
APPENDIX A: KEYPAD PROGRAMMING IN LADDER MODE .....	173
APPENDIX B: KEYPAD PROGRAMMING IN LADDER FUNCTION BLOCK .....	178
<b>IMO UK .....</b>	<b>190</b>
<b>IMO FRANCE .....</b>	<b>190</b>
<b>IMO ITALY .....</b>	<b>190</b>
<b>IMO CANADA .....</b>	<b>190</b>

## Summary of changes

This user manual is modified by firmware V3.0 and SMT Client programming software V3.0. SMT V3.0 adds some new functions with firmware version V3.0 to strong SMT function. The upgrade content is shown as the 2 tables below simply. More information about idiographic function to see function instruction.

### Edit and Display

	SMT V3.0	SMT V2.x
Ladder	300 lines	200 lines
FBD	260blocks	99blocks
LCD	4 lines * 16 characters	4 lines * 12 characters

### Contact and function block

	Input	Output	SMT V3.0	SMT V2.x
Auxiliary relay M	M	M	63(M01~M3F)	15(M1~MF)
Auxiliary relay N	N	N	63(N01~N3F)	Ladder: NO FBD: 15(N1~NF)
Temperature Input	AT		4(AT01~AT04)	NO
Analogue Output		AQ	4(AQ01~AQ04)	NO
PWM		P	2(P01~P02, P01 additional PLSY mode)	1(P1: PWM)
HMI			31(H01~H1F)	15(H1~HF)
Timer	T	T	Ladder: 31(T01~T1F) FBD: 250(T01~TFA)	15(T1~TF)
Counter	C	C	Ladder: 31(C01~C1F) FBD: 250(C01~CFA)	15(C1~CF)
RTC	R	R	Ladder: 31(R01~R1F) FBD: 250(R01~RFA)	15(R1~RF)
Analogue Comparator	G	G	Ladder: 31(G01~G1F) FBD: 250(G01~GFA)	15(G1~GF)
AS(Add-Sub)			Ladder: 31(AS01~AS1F) FBD: 250(AS01~ASFA)	N/A
MD(Mul-Div)			Ladder: 31(MD01~MD1F) FBD: 250(MD01~MDFA)	N/A
PID			Ladder: 15(PI01~PI0F) FBD: 30(PI01~PI1E)	N/A
MX(Multiplexer)	N/A	N/A	Ladder: 15(MX01~MX0F) FBD: 250(MX01~MXFA)	N/A
AR(Analogue Ramp)			Ladder: 15(AR01~AR0F) FBD: 30(AR01~AR1E)	N/A
DR(Data Register)			240(DR01~DRF0)	N/A
MU(MODBUS)			Ladder: 15(MU01~MU0F) FBD: 250(MU01~MUFA)	N/A
Block	B	B	Logic function: BOOLEAN 260(B001~B260)The capability of each block is alterable, and the total capability of block is 6000bytes	99(B01~B99)The capability of each block is fixed
PM04 (3 <sup>rd</sup> )			PM04(3 <sup>rd</sup> ) can be used with all version of SMT	PM04(3 <sup>rd</sup> ) cannot be used with SMT V3.x

## Chapter 1: Getting Started

The *iSmart* Relay is an electronic device. For safety reasons, please carefully read and follow the paragraphs with "WARNING" or "CAUTION" symbols. They are important safety precautions to be aware of while transporting, installing, operating, or examining the SMT Controller.



WARNING: Personal injury may result from improper operation.



CAUTION: The *iSmart* relay may be damaged by improper operation.

### Precaution for Installation



Compliance with the installation instructions and the user manual is absolutely necessary. Failure to comply could lead to improper operation, equipment damage or in extreme cases even death, serious bodily injury or considerable damage to property.



When installing the open-board models, insure that no wiring or foreign materials can fall into the exposed circuits and components. Damage to equipment, fire, or considerable damage to property could result.



Always switch off power before you wire, connect, install, or remove any module.



The wiring for the *iSmart* relay is open and exposed. For the open-board models, all electrical components are exposed. For this reason, it is recommended the *iSmart* relay be installed in an enclosure or cabinet to prevent accidental contact or exposure to the electrical circuits and components.



Never install the product in an environment beyond the limits specified in this user manual such as high temperature, humidity, dust, corrosive gas, vibration, etc.

### Precaution for Wiring



Improper wiring and installation could lead to death, serious bodily injury or considerable damage to property.



The *iSmart* relay should only be installed and wired by properly experienced and certified personnel.



Make sure the wiring of the *iSmart* relay meets all applicable regulations and codes including local and national standards and codes.



Be sure to properly size cables for the required current rating.



Always separate AC wiring, DC wiring with high-frequency switching cycles, and low-voltage signal wiring.

### Precaution for Operation



To insure safety with the application of the *iSmart* relay, complete functional and safety testing must be conducted. Only run the SMT after all testing and confirming safe and proper operation is complete. Any

potential faults in the application should be included in the testing. Failure to do so could lead to improper operation, equipment damage or in extreme cases even Death, serious bodily injury or considerable damage to property.



When the power is on, never contact the terminals, exposed conductors or electrical components. Failure to comply could lead to improper operation, equipment damage or in extreme cases even death, serious bodily injury or considerable damage to property.



It is strongly recommended to add safety protection such as an emergency stop and external interlock circuit in case the *iSmart* relay operation must be shut down immediately.

#### **Examination before Installation**

Every *iSmart* relay has been fully tested and examined before shipment. Please carry out the following examination procedures after unpacking your *iSmart* relay.

- Check to see if the model number of the SMT matches the model number that you ordered.
- Check to see whether any damage occurred to the SMT during shipment. Do not connect the *iSmart* relay to the power supply if there is any sign of damage.

**Contact IMO Precision Controls Ltd if you find any abnormal conditions as mentioned above.**

#### **Environmental Precautions**

The installation site of the *iSmart* relay is very important. It relates directly to the functionality and the lifespan of your SMT. Please carefully choose an installation site that meets the following requirements:

- Mount the unit vertically
- Environment temperature: 14°F - 143°F (-10°C to +60°C)
- Avoid placing SMT close to any heating equipment
- Avoid dripping water, condensation, or humid environment
- Avoid direct sunlight
- Avoid oil, grease, and gas
- Avoid contact with corrosive gases and liquids
- Prevent foreign dust, flecks, or metal scraps from contacting the *iSmart* relay
- Avoid electric-magnetic interference (soldering or power machinery)
- Avoid excessive vibration; if vibration cannot be avoided, an anti-rattle mounting device should be installed to reduce vibration.

#### **Disclaim of Liability**

We have reviewed the contents of this publication to ensure consistency with the hardware and software described. Since variance cannot be precluded entirely, we cannot guarantee full consistency. However, the information in this publication is reviewed regularly and any necessary corrections are included in subsequent editions.



## SMT Model Identification

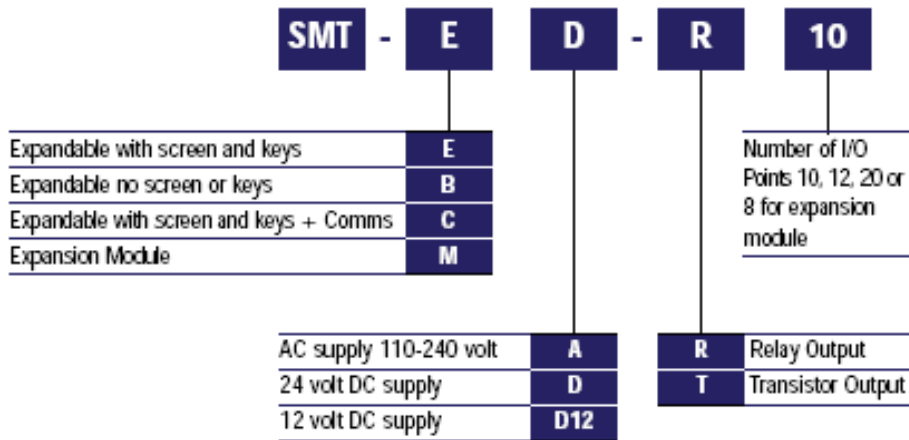

## Quick Start Setup

This section is a simple 5-steps guide to connecting, programming and operating your new *iSmart* relay. This is not intended to be the complete instructions for programming and installation of your system. Many steps refer to other sections in the manual for more detailed information.

### Install SMT Client Software

Install the SMT Client Software from the Resource CD or from the free internet download at [www.imopc.com](http://www.imopc.com)

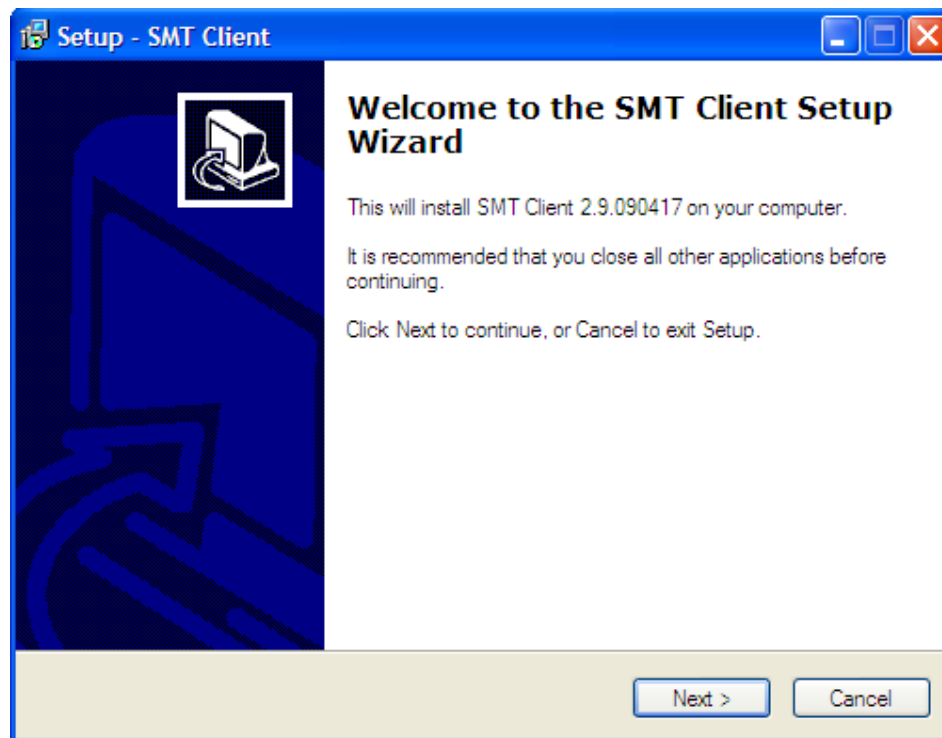

### Connect Power to *iSmart* relay

Connect power to the *iSmart* using the below wiring diagrams for AC or DC supply for the applicable modules. See “Chapter 2: Installation” for complete wiring and installation instructions.

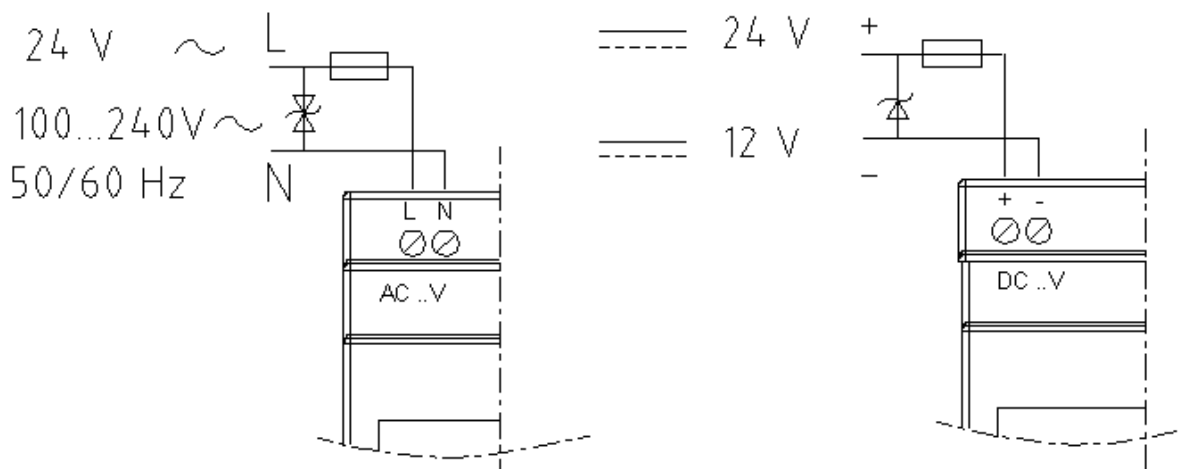

### Connect Programming Cable

Remove the plastic connector cover from the SMT using a flathead screwdriver as shown in the figure below. Insert the plastic connector end of the programming cable into the *iSmart* relay as shown in the figure below. Connect the opposite end of the cable to an RS232 serial port on the computer. If USB programming is required please use PC501 in conjunction with SMT-PC03. For Ethernet programming, please use SMT-ENET in conjunction with SMT-PC03.

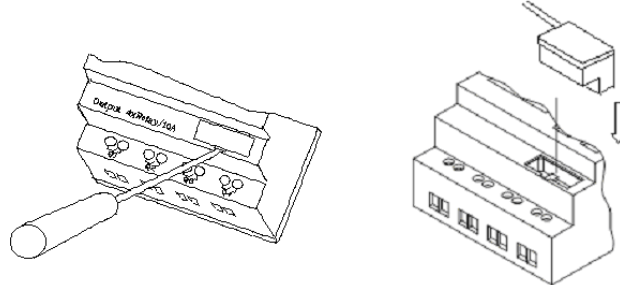

### Establish Communication

- Open the SMT Client software and select “New Ladder Document” as shown below left.
- Select “Operation/Link Com Port...” as shown below right.

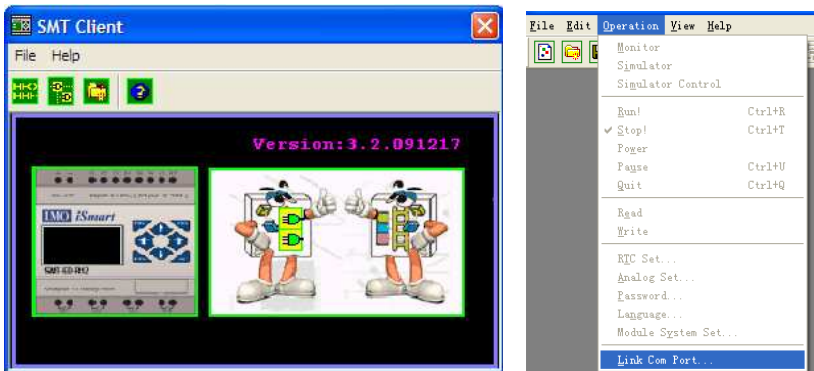

- Select the correct Com Port number where the programming cable is connected to the computer then press the “Link” button.

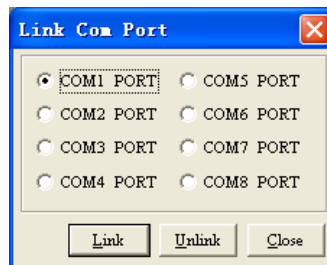

- The SMT Client will then begin to detect the connected smart relay to complete its connection.

## Write simple program

- Write a simple one rung program by clicking on the leftmost cell at line 001 of the programming grid, then click on the “M” contact icon on the ladder toolbar, as shown below. Select M01 and press the OK button. See Chapter 4: Ladder Programming instructions for complete instruction set definitions.

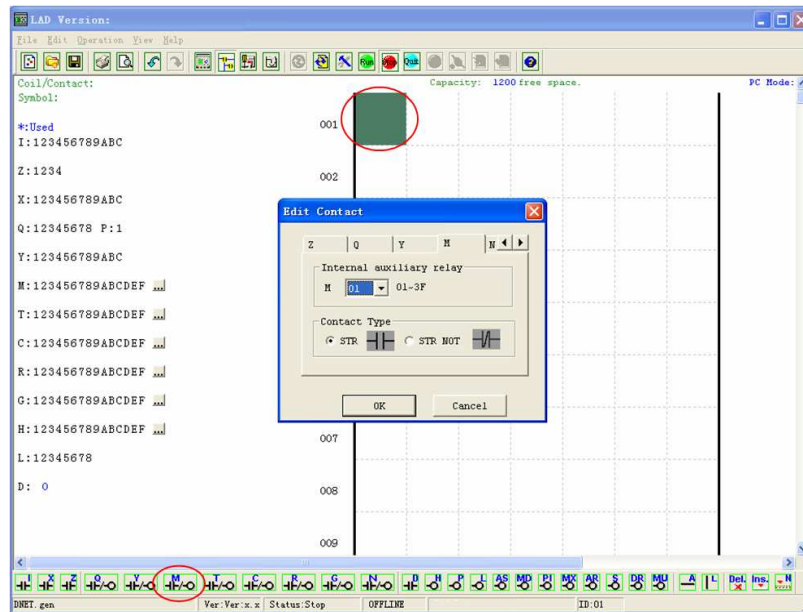

**Note:** If the ladder toolbar is not visible at the bottom of the screen, select **View>>Ladder Toolbar** from the menu to enable.

- Use the “A” key on your keyboard (or the “A” icon on the ladder toolbar) to draw the horizontal circuit line from the M contact to the right most cell, as shown below.

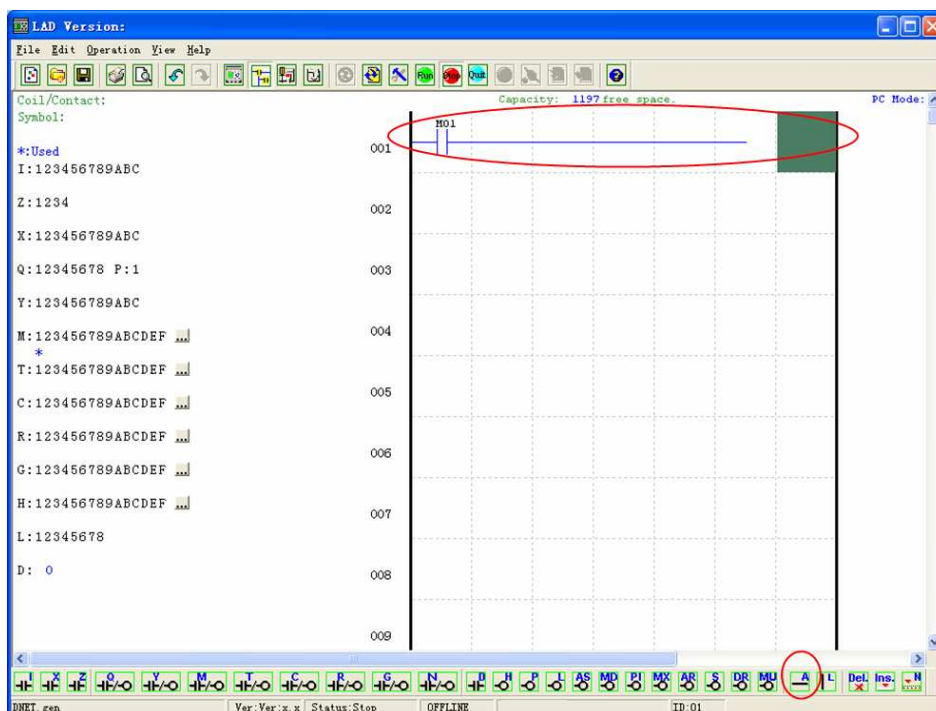

c. Select the “Q” coil icon from the ladder toolbar and drop it on the right most cells. Select Q01 from the dialog and press OK as shown below. See Chapter 4: Ladder Programming instructions for complete instruction set definitions.

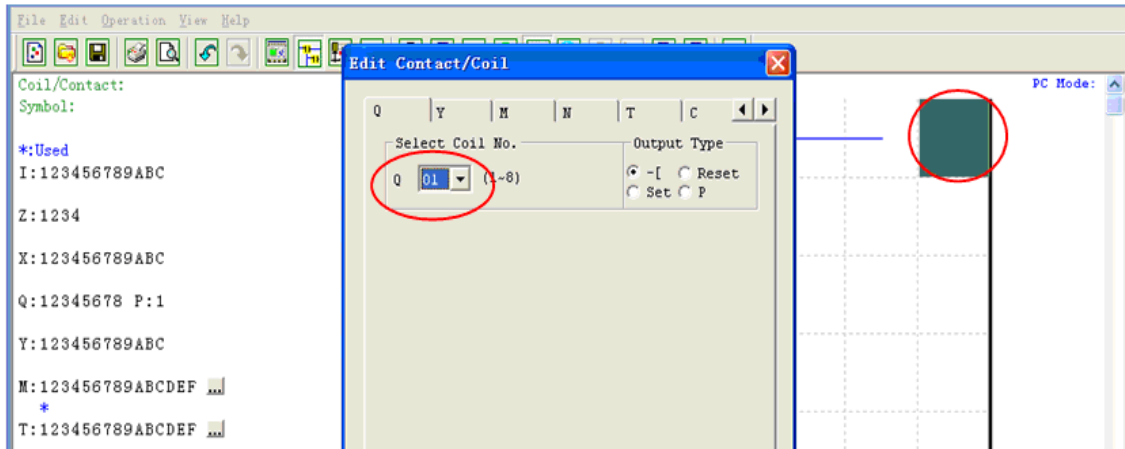

d. Test the simple program. From the Operation menu, select the Write function and write the program to the connected iSmart as shown below.

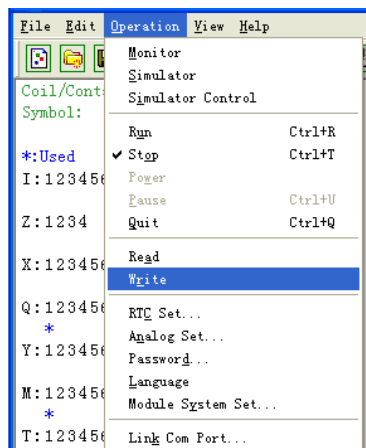

e. Select the RUN icon from the toolbar, and select “No” when the pop-up message asks “Do you want to read program from module?”, as shown below.

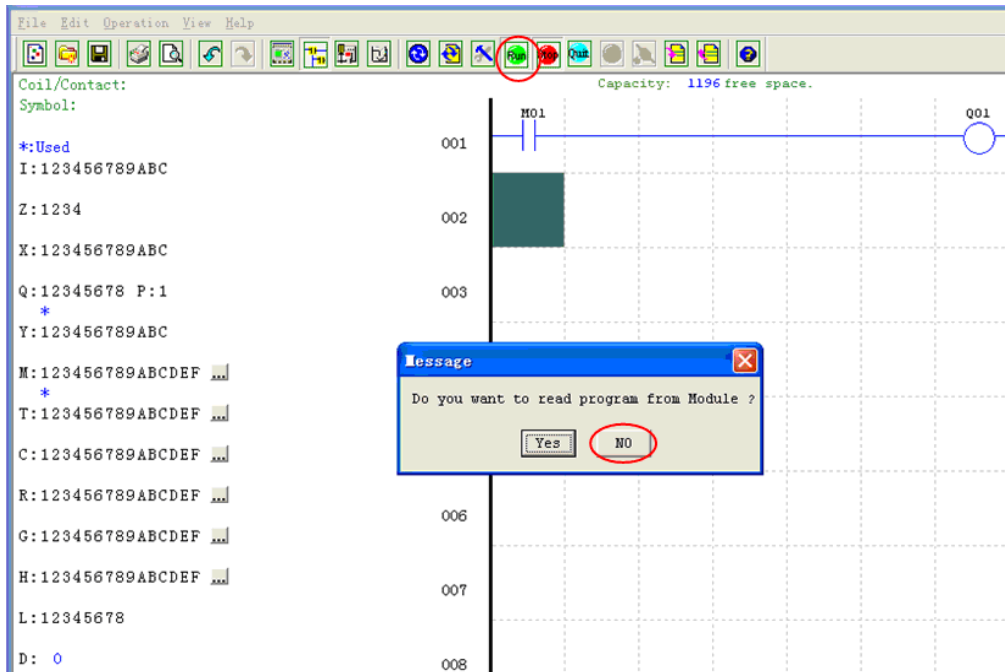

f. On the Input Status dialog, click on M01 to activate the contact M01 which will turn ON the Output Q01 as shown below. The highlighted circuit will show active and the first Output (Q01) on the connected smart relay will be ON. See Chapter 3: Programming Tools for more detailed software information.

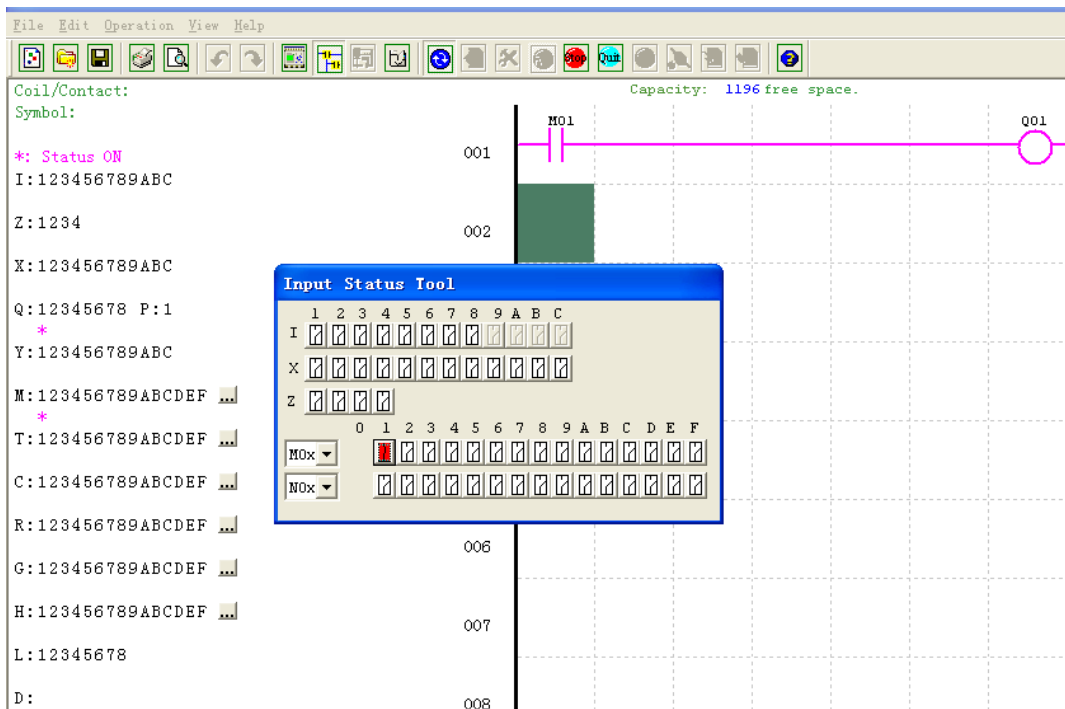

## Chapter 2: Installation

### General Specifications

SMT is a miniature smart Relay with a maximum of 44 I/O points and can be programmed in Relay Ladder Logic or FBD (Function Block Diagram) program. The SMT can expand to its maximum I/O count by adding 3 groups of 4-input and 4-output modules.

POWER SUPPLY	
INPUT POWER VOLTAGE RANGE	24V DC MODELS: 20.4-28.8V 12V DC MODELS: 10.4~14.4V AC MODELS: 85-265V 24V AC MODELS: 20.4-28.8V
POWER CONSUMPTION	24VDC: 12-POINT :125MA 20-POINT: 185MA 12VDC: 12-POINT: 195MA 20-POINT: 265MA 100-240VAC: 100MA 24VAC: 290MA
WIRE SIZE (ALL TERMINALS)	26 TO 14 AWG

PROGRAMMING	
PROGRAMMING LANGUAGES	LADDER/FUNCTION BLOCK DIAGRAM
PROGRAM MEMORY	300 LINES OR 260 FUNCTION BLOCKS
PROGRAMMING STORAGE MEDIA	FLASH
EXECUTION SPEED	10MS/CYCLE
LCD DISPLAY	4 LINES X 16 CHARACTERS
<b>TIMERS</b>	
MAXIMUM NUMBER	LADDER: 31 ; FBD: 250
TIMING RANGES	0.01s-9999MIN
<b>COUNTERS</b>	
MAXIMUM NUMBER	LADDER: 31 ; FBD: 250
HIGHEST COUNT	999999
RESOLUTION	1
<b>RTC (REAL TIME CLOCK)</b>	
MAXIMUM NUMBER	LADDER: 31 ; FBD: 250
RESOLUTION	1MIN
TIME SPAN AVAILABLE	WEEK, YEAR, MONTH, DAY, HOUR, MIN
COMPARE INSTRUCTIONS (ANALOGUE, ANALOGUE*GAIN + OFFSET, TIMER, COUNTER, TEMPERATURE INPUT (AT), ANALOGUE OUTPUT (AQ), AS, MD, PI, MX, AR AND DR VALUES)	
<b>ANALOGUE COMPARE</b>	
MAXIMUM NUMBER	LADDER: 31 ; FBD: 250
COMPARE VERSUS OTHER INPUTS	ANALOGUE, TIMER, COUNTER, TEMPERATURE INPUT (AT), ANALOGUE OUTPUT (AQ), ANALOGUE*GAIN + OFFSET, AS, MD, PI, MX, AR, DR, OR NUMERIC VALUES

ENVIRONMENTAL	
ENCLOSURE TYPE	IP20
MAXIMUM VIBRATION	1G ACCORDING TO IEC60068-2-6
OPERATING TEMPERATURE RANGE	-4° TO 131°F (-20° TO 55°C)
STORAGE TEMPERATURE RANGE	-40° TO 158°F (-40° TO 70°C)
MAXIMUM HUMIDITY	90% (RELATIVE, NON-CONDENSING)
VIBRATION	0.075MM AMPLITUDE, 1.0G ACCELERATION
WEIGHT	8-POINT: 190G 10,12-POINT: 230G (C TYPE: 160G) 20-POINT: 345G (C TYPE: 250G)
AGENCY APPROVALS	CUL, CE, UL



DISCRETE INPUTS	
CURRENT CONSUMPTION	3.2MA @24VDC 4MA @12VDC 1.3MA @100-240VAC 3.3MA @24VAC
INPUT SIGNAL "OFF" THRESHOLD	24VDC: <5VDC; 12VDC: <2.5VDC 100-240VAC: <40VAC 24VAC: <6VAC
INPUT SIGNAL "ON" THRESHOLD	24VDC: >15VDC; 12VDC: >7.5VDC 100-240VAC: >79VAC 24VAC: >14VAC
INPUT ON DELAY	24, 12VDC: 5ms 240VAC: 25ms; 120VAC: 50ms 24VAC: 5ms
INPUT OFF DELAY	24, 12VDC: 3ms 240VAC: 90/85ms 50/60Hz ; 120VAC: 50/45ms 50/60Hz 24VAC: 3ms
TRANSISTOR DEVICE COMPATIBILITY	NPN, 3-WIRE DEVICE ONLY
HIGH SPEED INPUT FREQUENCY	1kHz
STANDARD INPUT FREQUENCY	< 40 Hz
REQUIRED PROTECTION	INVERSE VOLTAGE PROTECTION REQUIRED

TRANSISTOR OUTPUTS	
PWM MAX. OUTPUT FREQUENCY	1.0kHz (0.5ms ON,0.5ms OFF)
STANDARD MAX. OUTPUT FREQUENCY	100Hz
VOLTAGE SPECIFICATION	10-28.8VDC
CURRENT CAPACITY	1A
MAXIMUM LOAD	RESISTIVE: 0.5A/POINT INDUCTIVE: 0.3A/POINT
MINIMUM LOAD	0.2MA

**Product Specifications**

	Part Number:	Power	Digital In	Digital Out	Analogue In	Analogue Out	HMI	Comments
<b>BASE MODELS</b> (STOCKED)	SMT-EA-R10-V3	100-240Vac	6 AC	4 (8A Rly)	-	-	Y	
	SMT-EA-R20-V3	100-240Vac	12 AC	8 (8A Rly)	-	-	Y	
	SMT-ED-R12-V3	24Vdc	8 DC*	4 (8A Rly)	2 (0-10V)	-	Y	2 High Speed Inputs (up to 1Khz)
	SMT-ED-R20-V3	24Vdc	12 DC*	8 (8A Rly)	4 (0-10V)	-	Y	2 High Speed Inputs (up to 1Khz)
	SMT-ED12-R12-V3	12Vdc	8 DC*	4 (8A Rly)	2 (0-10V)	-	Y	2 High Speed Inputs (up to 1Khz)
	SMT-BA-R10-V3	100-240Vac	6 AC	4 (8A Rly)	-	-	N	
	SMT-BA-R20-V3	100-240Vac	12 AC	8 (8A Rly)	-	-	N	
	SMT-BD-R12-V3	24Vdc	8 DC*	4 (8A Rly)	2 (0-10V)	-	N	2 High Speed Inputs (up to 1Khz)
	SMT-BD-R20-V3	24Vdc	12 DC*	8 (8A Rly)	4 (0-10V)	-	N	2 High Speed Inputs (up to 1Khz)
	SMT-CD-R20-V3	24Vdc	12 DC*	8 (8A Rly)	4 (0-10V)	-	Y	2 HSI (1Khz), RS485 Modbus, Link
	SMT-CD-T20-V3	24Vdc	12 DC*	8(0.5A Trn)	4 (0-10V)	-	Y	2 PWM (0.5Khz), RS485 Modbus
<b>EXPANSION / EXTRAS</b> (STOCKED)	SMT-MA-R8	100-240Vac	4 AC	4 (8A Rly)			-	Max 3 per Base
	SMT-MD-R8	24Vdc	4 DC	4 (8A Rly)			-	Max 3 per Base
	SMT-MD-T8	24Vdc	4 DC	4(0.5A Trn)			-	Max 3 per Base
	SMT-MD-4AI	24Vdc			4 (V, mA)		-	Max 1 per Base
	SMT-4PT	24Vdc			4 PT100		-	Max 1 per Base
	SMT-2AO	24Vdc				2 (V, mA)	-	Max 2 per Base
	SMT-MODBUS	24Vdc					-	RS485 Modbus**
	SMT-DEVICENET	24Vdc					-	DeviceNet Slave**
	SMT-PC03	-						PC-Link Programming cable
	SMT-PM04-V3	-						32K Flash Memory module
	<b>MADE TO ORDER</b>	SMT-ED-T12-V3	24Vdc	8 DC*	4(0.5A Trn)	2 (0-10V)		Y
SMT-ED-T20-V3		24Vdc	12 DC*	8(0.5A Trn)	4 (0-10V)		Y	2 PWM (0.5Khz)
SMT-BD-T12-V3		24Vdc	8 DC*	4(0.5A Trn)	2 (0-10V)		N	2 PWM (0.5Khz)
SMT-BD-T20-V3		24Vdc	12 DC*	8(0.5A Trn)	4 (0-10V)		N	2 PWM (0.5Khz)
SMT-CD12-R20-V3		12Vdc	12 DC*	8 (8A Rly)	4 (0-10V)		Y	RS485 Modbus, Link Function
SMT-ED12-R20-V3		12Vdc	12 DC*	8 (8A Rly)	4 (0-10V)	-	Y	2 High Speed Inputs (up to 1Khz)
SMT-EA24-R12-V3		24Vac	6 AC	4 (8A Rly)			Y	24Vac inputs, and power
SMT-EA24-R20-V3		24Vac	12 AC	8 (8A Rly)			Y	24Vac inputs, and power
SMT-MA24-R8		24Vac	4 AC	4 (8A Rly)				24Vac inputs, and power
SMT-ENET		24Vdc					-	Ethernet Expansion**
SMT-PROFIBUS		24Vdc					-	Profibus Slave Expansion**

\*Analogue Inputs can be used as Digital, number shown includes Analogues

\*\*One comms expansion module per base unit

## Mounting

### DIN-rail Mounting

The ISmart relay should always be mounted vertically. Press the slots on the back of the SMT and expansion module plug CONNECTOR onto the rail until the plastic clamps hold the rails in place. Then connect the expansion module and CONNECTOR with the Master (press the PRESS-BUTTON simultaneously)

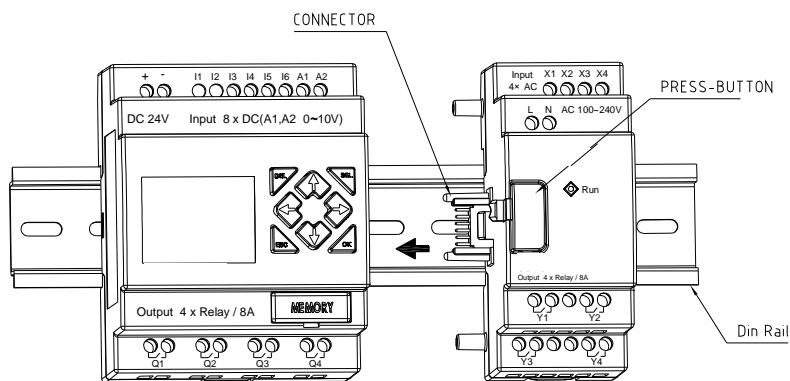
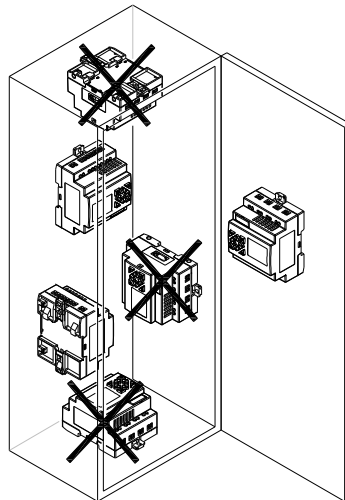
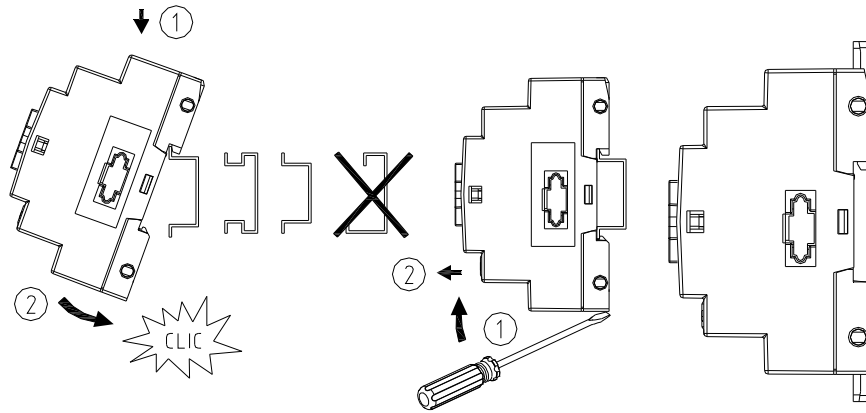

It is recommended to apply a DIN-rail end clamp to hold the SMT in place.

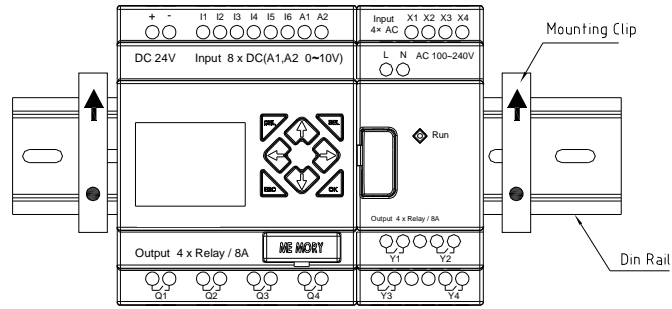

## Direct Mounting

Use M4 screws to direct mount the SMT as shown. For direct installation of the expansion module, slide the expansion module and connect with the Master after the Master is fixed.

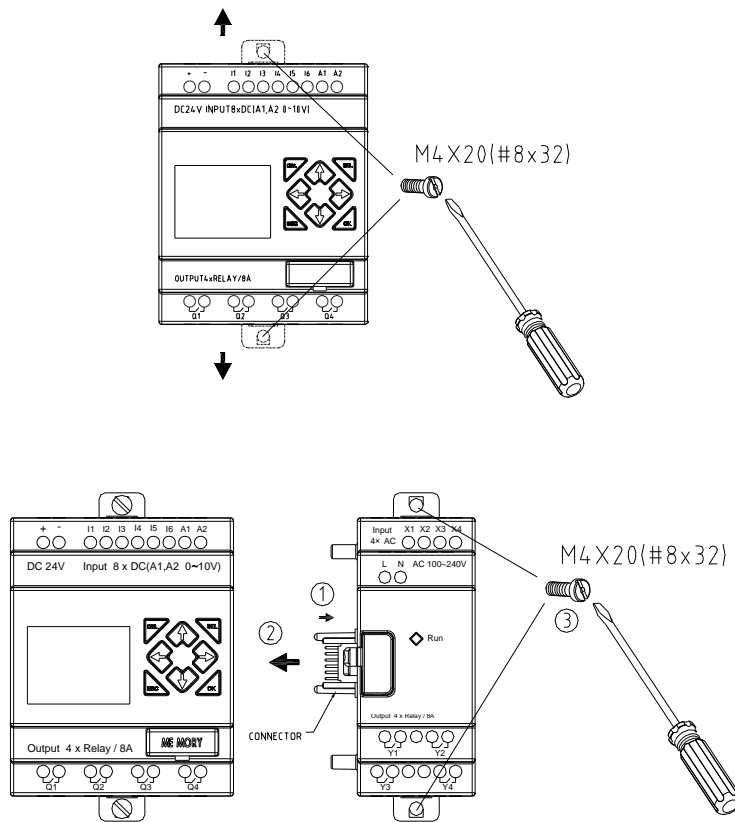

## Wiring

**!** **WARNING:** The I/O signal cables should not be routed parallel to the power cable, or in the same cable trays to avoid the signal interference.

**!** To avoid a short circuit on the load side, it is recommended to connect a fuse between each output terminals and loads.

## Wire size and Terminal Torque

mm <sup>2</sup>	0.14...1.5	0.14...0.75	0.14...2.5	0.14...2.5	0.14...1.5
AWG	26...16	26...18	26...14	26...14	26...16
∅ 3.5 (0.14in)					
		lb-in	5.4		

## Input 12/24V DC

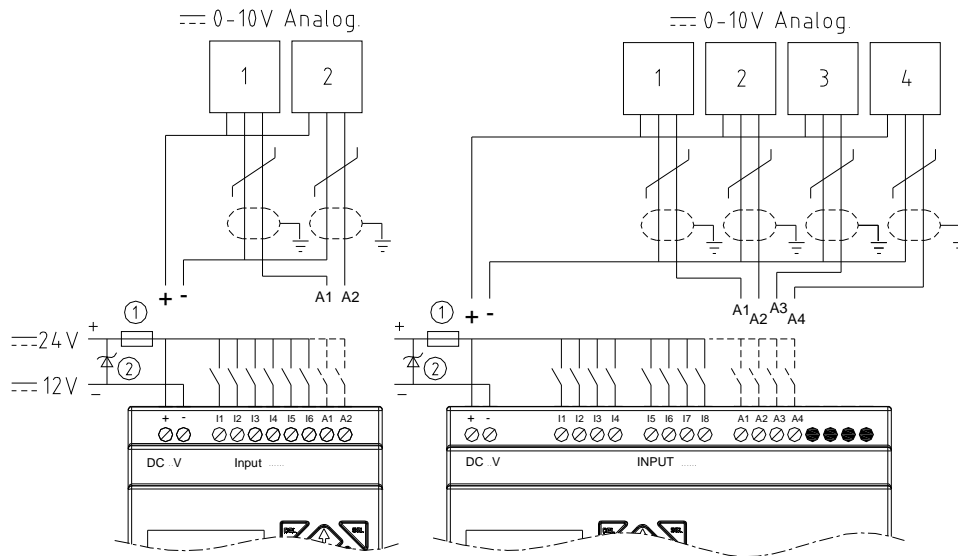

## Sensor Connection

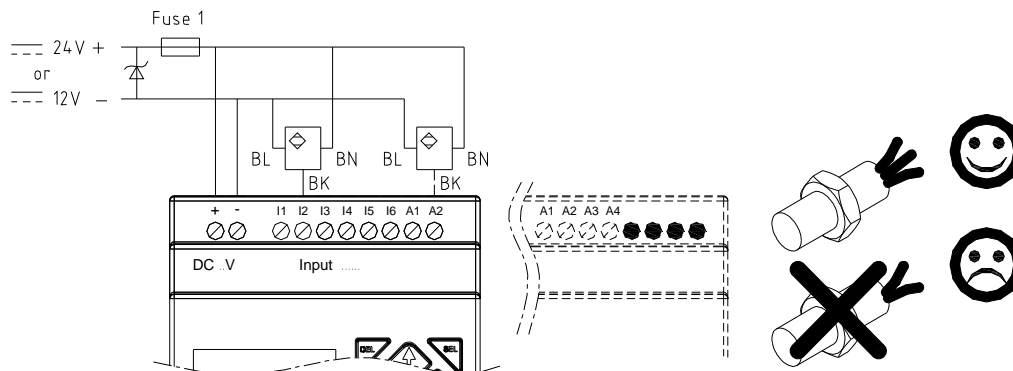

## Input 100~240V /24V AC

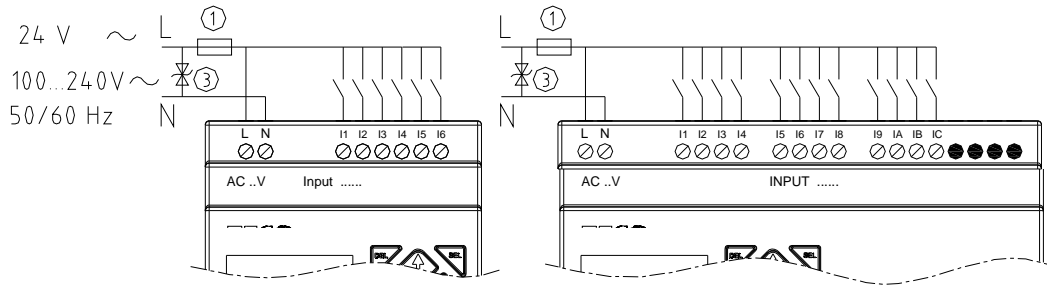

## Output (Relay)

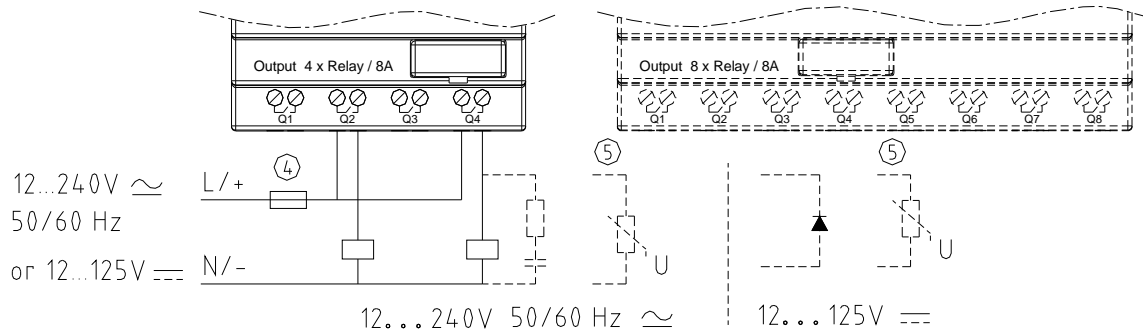

## Output (Transistor)

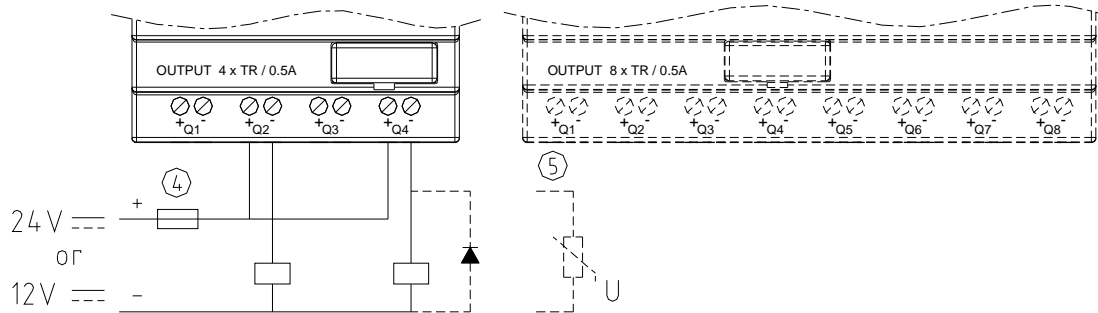

## Data Link OR Remote I/O Link

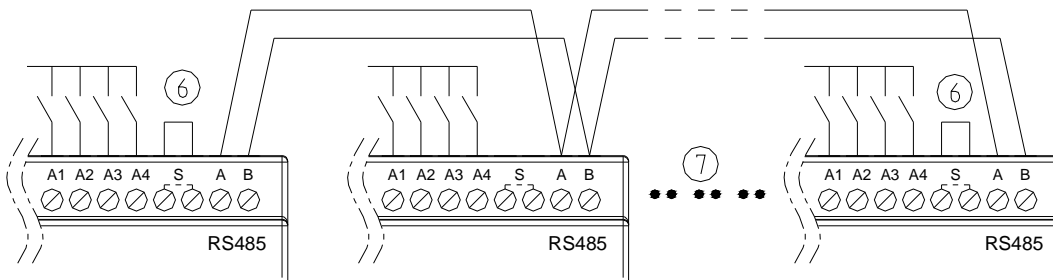

The power supply and the I/O supply should share the same power source. Only short circuit the first and the last module.

When I/O link, the net can connect 8 products in max. (ID: 0-7).



When Remote I/O is available, it only can connect 2 products max (Master & Slave).

- 1 - 1A quick-blowing fuse, circuit-breaker or circuit protector
- 2 - Surge absorber (36V DC)
- 3 - Surge absorber (400V AC)
- 4 - Fuse, circuit-breaker or circuit protector
- 5 - Inductive load
- 6 - Only short circuit the first product and the last product
- 7 - Comply with standard: EIA RS-485.

※ More information about C type communication to see “**Chapter 7 - 20 Point C type High-powered Models Instruction**”.

### **B type Indicator Light**

There is an indicator light to indicate the status of SMT (Blind type) smart, and the below table shows the relationship between the light and the SMT status.

STATE OF LIGHT	DESCRIPTION
	POWER UP, SMT IS STOPPING
	FLICKER SLOW(2Hz), SMT IS RUNNING
	FLICKER QUICK(5Hz), SMT IS UNDER FAILURE STATUS
	—ROM ERROR —LOGIC ERROR IN USER PROGRAM —EEPROM ERROR —EXPANSION MODEL ERROR

## Chapter 3: Program Tools

### PC Programming Software “SMT Client”

The SMT Client programming software provides two edit modes, Ladder Logic and Function Block Diagram (FBD). The SMT Client software includes the following features:

1. Easy and convenient program creation and editing.
2. Programs can be saved on a computer for archiving and reuse. Programs can also be uploaded directly from a SMT and saved or edited.
3. Enables users to print programs for reference and review.
4. The Simulation Mode allows users to run and test their program before it is loaded to the controller.
5. Real-time communication allows the user to monitor and force I/O on the ISmart relay operation during RUN mode.

### Installing the Software

Install the SMT Client (free download from the IMO website):

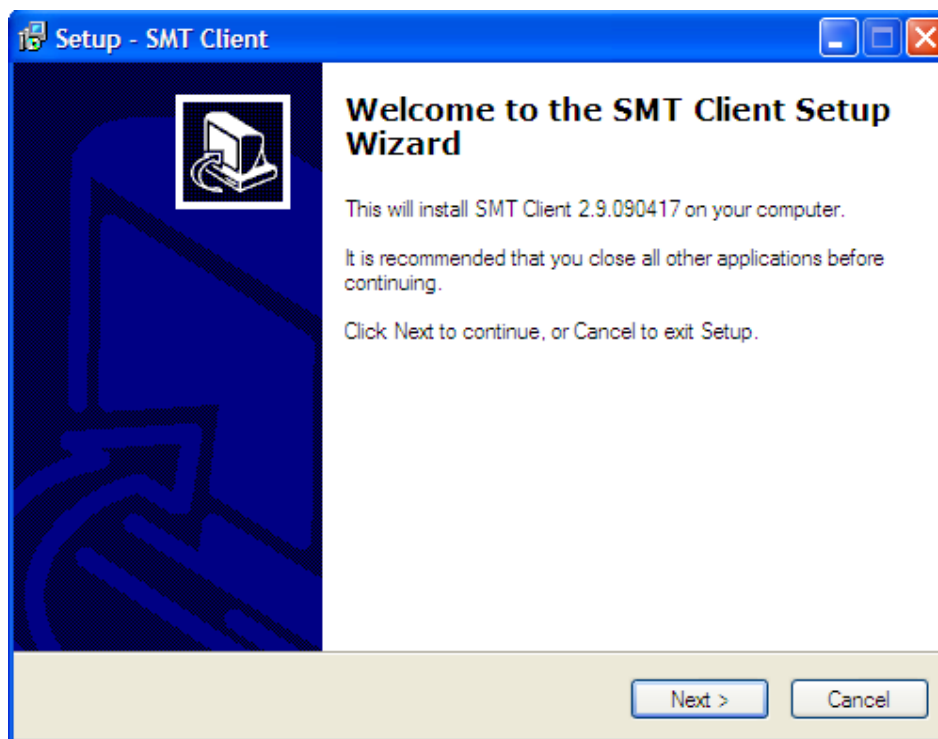



## Connecting the Software

Remove the plastic connector cover from SMT using a flathead screwdriver as shown in the figure below. Insert the plastic connector end of the programming cable into the ISmart relay as shown in the figure below. Connect the opposite end of the cable to an RS232C serial port on the computer.

## Start Screen

Run the SMT Client software and the below Start screen will be displayed. From this screen, you can perform the following functions



### New Ladder Program

Select **File -->New -->New LAD** to enter the development environment for a new Ladder program.

### New FBD Program

Select **File -->New -->New FBD** to enter the development environment for a new FBD (Function Block Diagram) program.

### Open Existing File

Select **File -->Open** to choose the type of file to open (Ladder or FBD), and choose the desired program file, and then click Open.

## Ladder Logic Programming Environment

The Ladder Logic Programming Environment includes all the functions for programming and testing the SMT using the Ladder Logic programming language. To begin a new program select **File-->New**, and select the desired model of SMT, and the number of connected expansion units if applicable, as shown below.

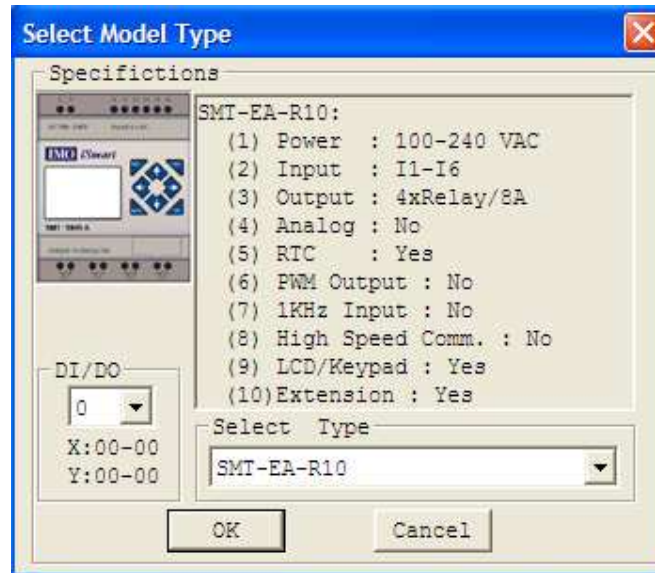

The Ladder programming environment includes the following Menus, Icons and Status Displays

1. Menu bar – Five menu selections for program development and retrieval, editing, communication to connected controllers, configuration of special functions and viewing preference selections.
2. Main Toolbar – (From Left to Right)  
Icons for create a new program, open a program, save a program and print a program.  
Icons for Keypad, Ladder view, HMI/Text edit and Symbol (comments) edit.  
Icons for Monitor, Simulator, Simulator Controller, Controller Mode changes (Run, Stop, and Quit), and Read/Write programs from/to the *iSmart* relay.
3. Usage List – List for all memory types and addresses used with the current open program. Used addresses are designated by a “\*” symbol below each address.
4. Amount of free programming memory available.
5. Current Mode – operation mode of the controller, or simulator, from the connected PC.
6. Ladder Toolbar – Icons for selecting and entering all available Ladder Logic instructions.
7. Status Bar – Status of current open project and connect *iSmart* relay.

LAD Version: 1

File Edit Operation View Help

Coil/Contact: Capacity: 1200 free space. 5 PC Mode

Symbol:

\*:Used  
 I: 123456789ABC 3  
 Z: 1234  
 X: 123456789ABC  
 Q: 12345678 P: 1  
 Y: 123456789ABC  
 M: 123456789ABCDEF ...  
 T: 123456789ABCDEF ...  
 C: 123456789ABCDEF ...  
 R: 123456789ABCDEF ...  
 G: 123456789ABCDEF ...  
 H: 123456789ABCDEF ...  
 L: 12345678  
 D: 0

001 4

002

003

004

005

006

007

008

009

I X Z O Y M T C R G N D H P L AS MD PI MX AR S DR MU A L Del. Ins. 6

DNET.gen Ver: Ver: x. x Status: Stop OFFLINE Model: SMT-EA-R10 ID: 01 7

## Programming

The SMT Client software can be programmed by either drag-and-drop of instructions or by using keyboard entry commands. Below is an example of some common methods of entering programming instructions.

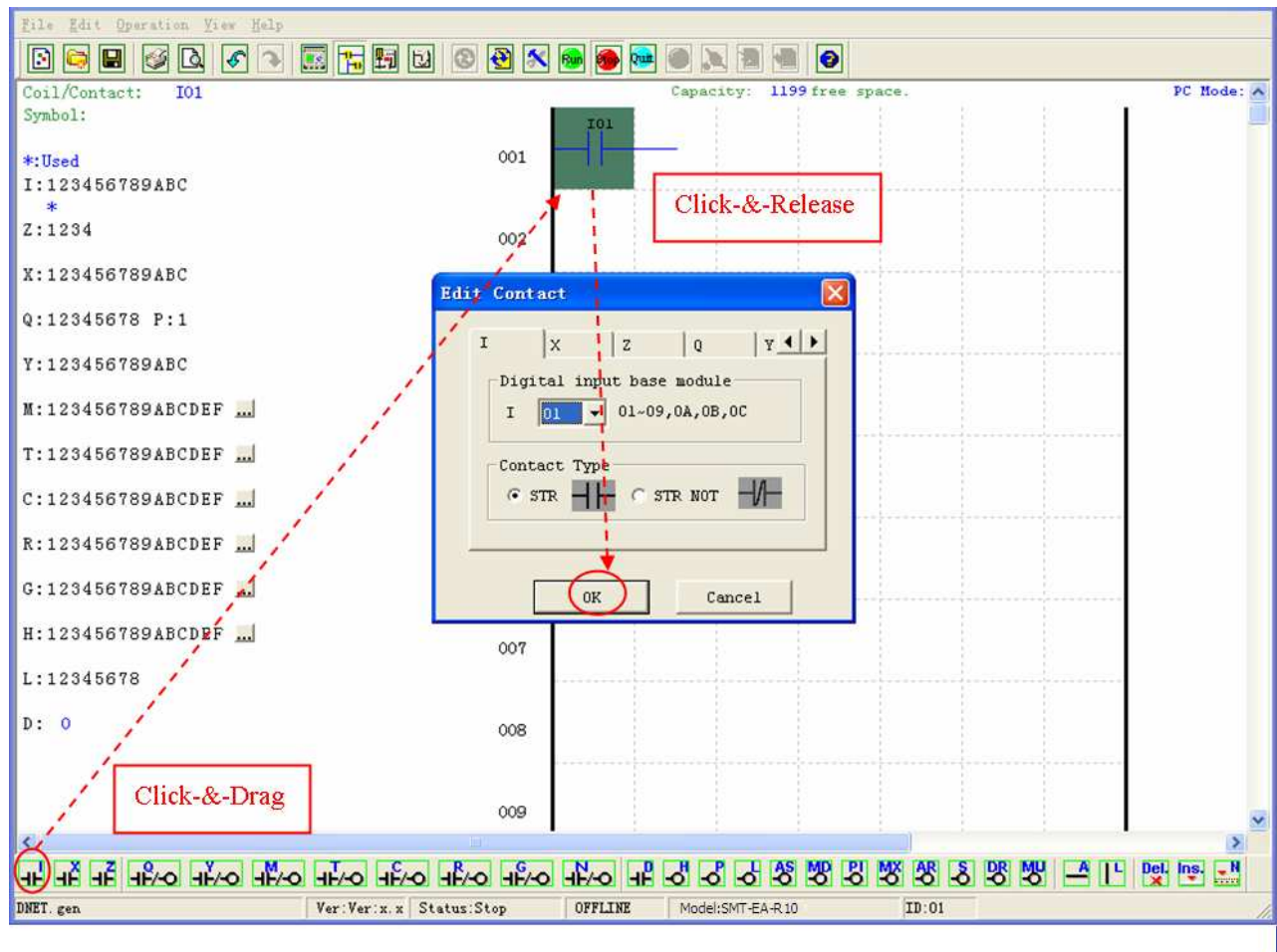

The “A” and “L” keys or icons are used to complete parallel and serial circuits. The right column is for output coils.

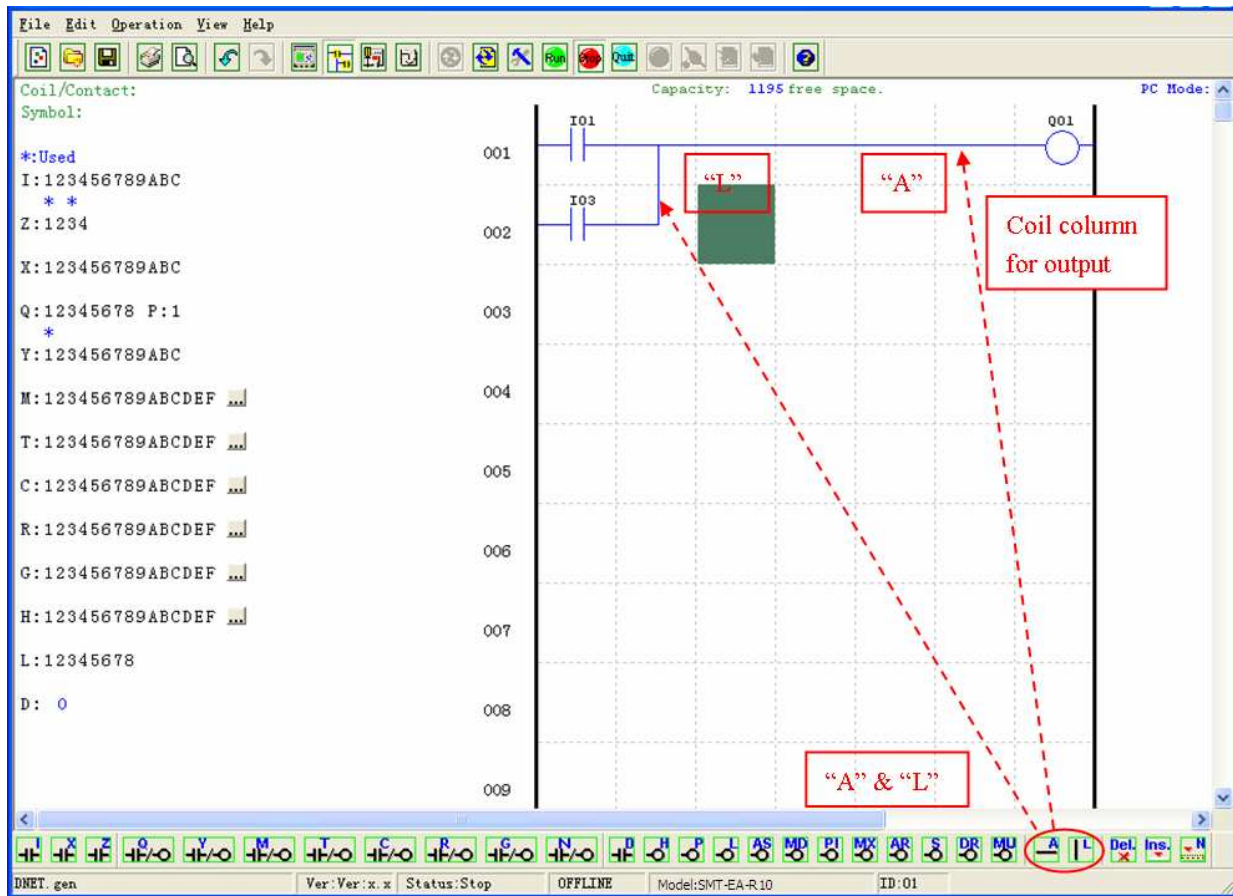

## Simulation Mode

The SMT Client software includes a built-in simulator to test and debug programs easily without the need of a controller. To activate simulation mode, simply press the red RUN icon. The program below is shown in simulation mode, identifying the significant available features.

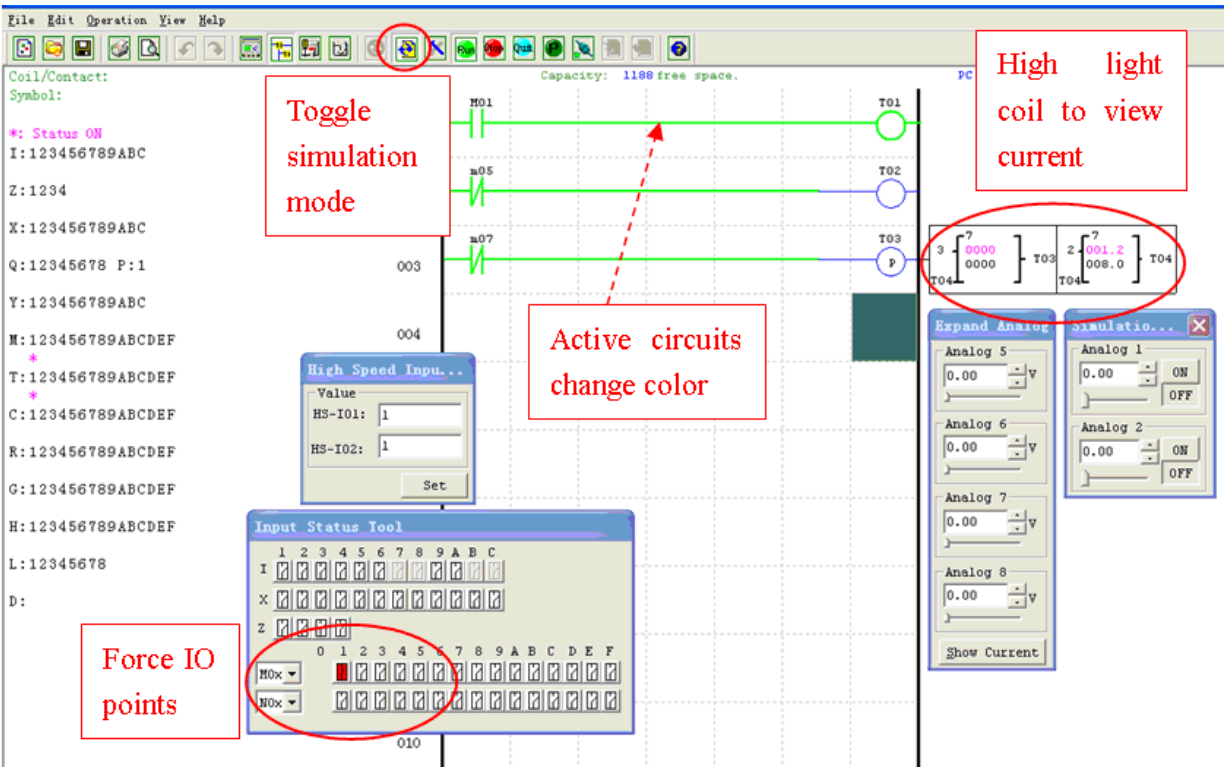

## Establish Communication

The following is the simple procedure for establishing communication between PC and the ISmart relay.

- a. Select “Operation/Link Com Port...” as shown below.

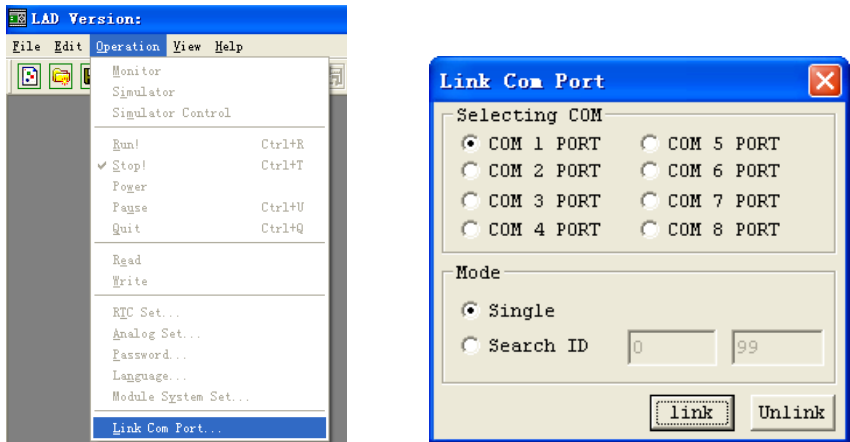

- b. Select the correct Com Port number where the programming cable is connected to the computer then press the “Link” button.
- c. The SMT Client software will then begin to detect the connected smart relay to complete its connection.

## Writing a Program to the iSmart

From the Operation menu, select the Write function and write the program to the connected smart relay as shown below, or press Write button to write program to connected smart relay as shown below.

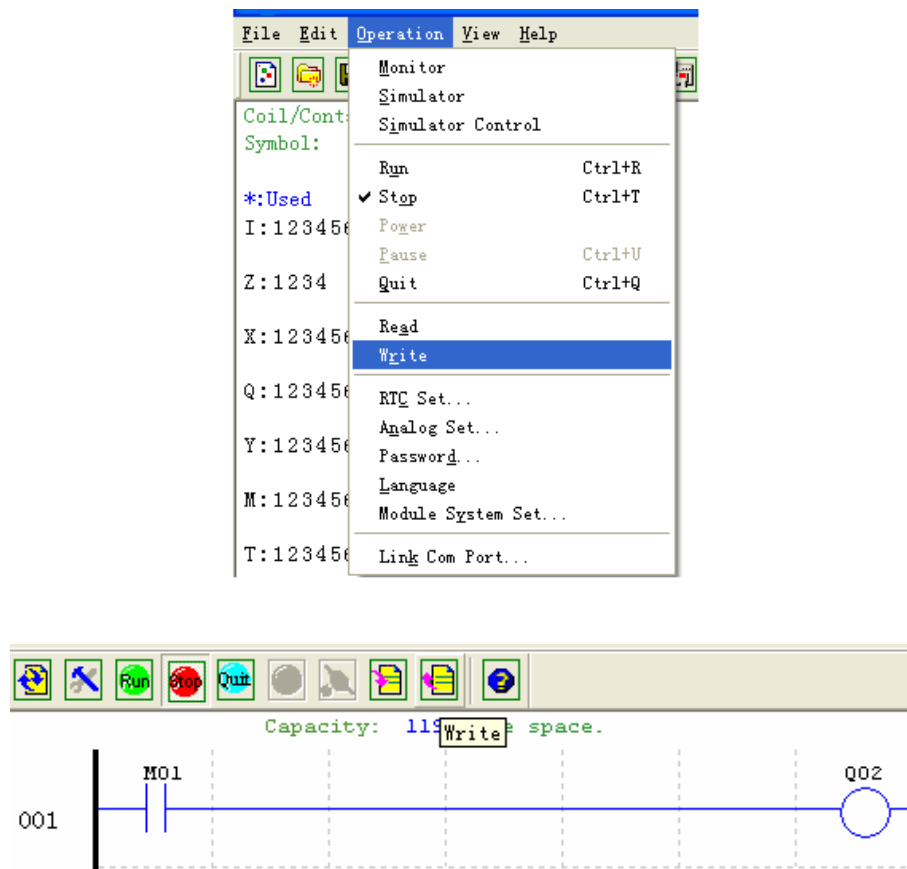

### Operation menu

The Operation menu, includes several system configuration functions for both online and offline setup. The following explains the details of each function.

Monitor – Online function for runtime monitor and editing when connected to a controller

Simulator – Offline function for testing and debugging a program.

Simulator Control – Self-motion simulator control

Run-Stop-Quit – Mode change selections for both runtime editing and simulation mode.

Read-Write – Reading and writing programs to and from a connected iSmart relay.

RTC Set – Online function for setup of the Real-time clock/calendar (see dialog below left)

Analogue Set – setup analogue input A01-A08 gain and offset (see dialog below right)

Password – Set a password for accessing the current program after upload to the smart relay

Language – Change iSmart relay menu language

Module System Set – Dialog for changing important system setup functions including Module ID,

Remote I/O preferences, Expansion I/O settings, and Retentive memory preferences (Keeping) for (C)

Counters, (M) Auxiliary Coils, and (Z) keypad input set and the LCD Backlight.

Link Com Port – Select the port communication with ISmart relay.

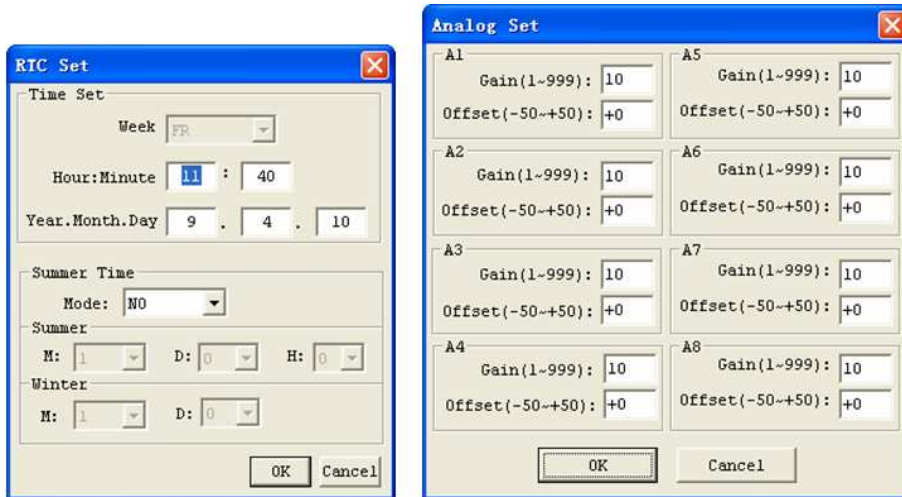

## Online Monitoring/Editing

The SMT Client software allows for online monitoring of the currently running program during runtime. Additional online functions include, I/O forcing, and Mode changes (Run/Stop/Quit).

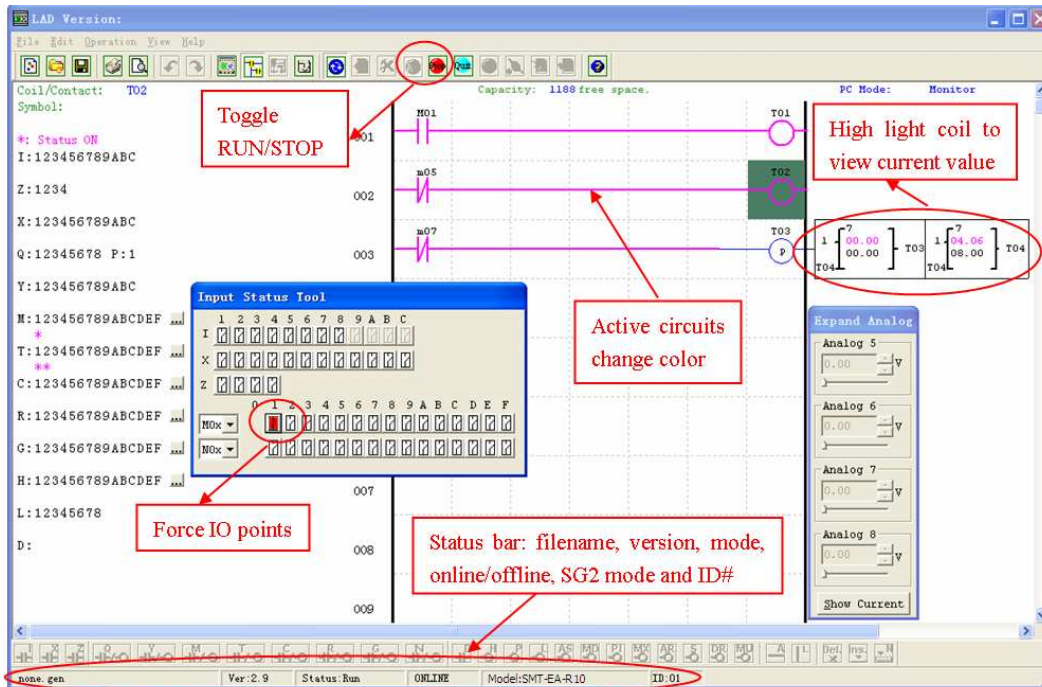

✘ The SMT Client software does not support runtime logic editing changes. All logic edits to contacts, coils, Timers/Counters, and circuit connecting lines must be written to the connected smart relay while in Stop mode.



## HMI/TEXT

This function block can display information on 16×4 LCD screen. Information displaying can be present value or target value of Counter, Timer, RTC and Analogue comparator etc. Under running mode, to modify the target value of timer, counter and analogue comparator via HMI is available. HMI can display the status of input terminal (I, Z, X) and Auxiliary terminal M, N (only FBD).

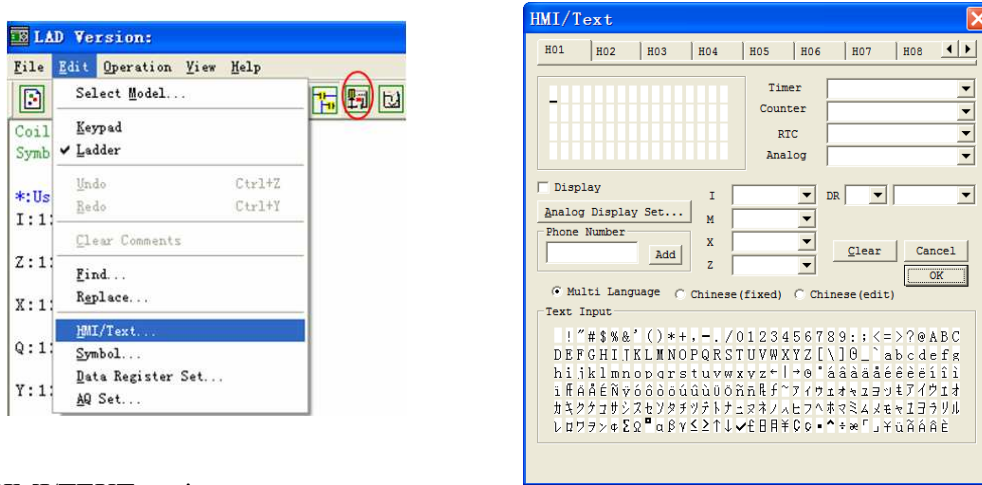

HMI/TEXT setting:

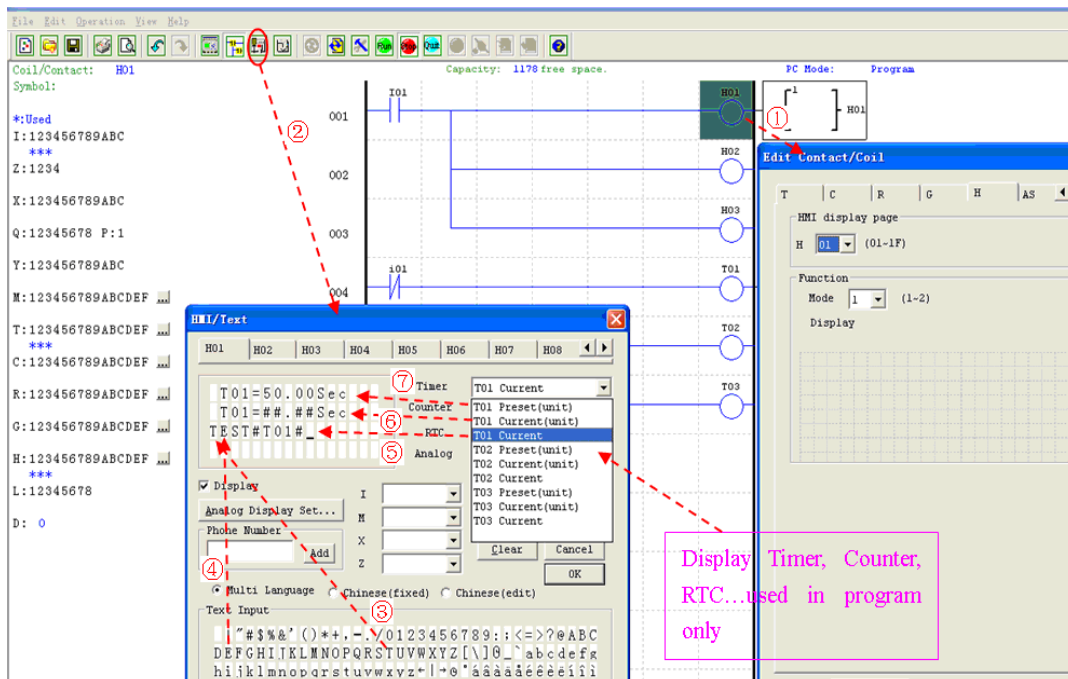

- ① Enter H01 coil
- ② Into HMI/TEXT edit frame
- ③ Choose the “T”
- ④ Choose the “E”
- ⑤ Choose “T01 current”

⑥ Choose T01 current (unit)

⑦ Choose T01 present (unit), user can modify T01 preset value when H coil enable and display on LCD

Download to SMT, and I01 turn ON, or press “SEL” if the H coils is set to mode 1, then the SMT LCD will display the first H text as shown below.

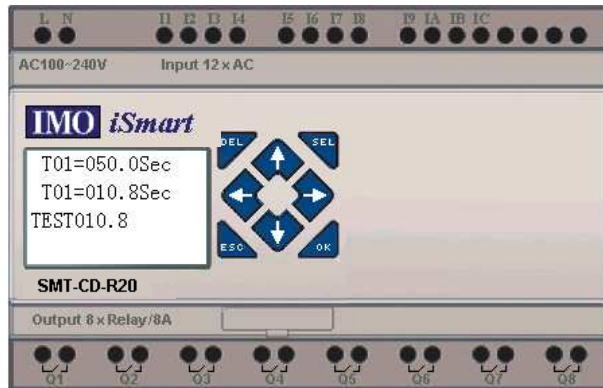

I , Press “↑” or “↓” to choice the nearest H coil

II , Press “SEL”+“↑” or “↓”and “OK” update T01 preset value (In this example, 050.0 can update, T01 preset value depends on HMI/TEXT edit frame setting.)

HMI/TEXT Example:

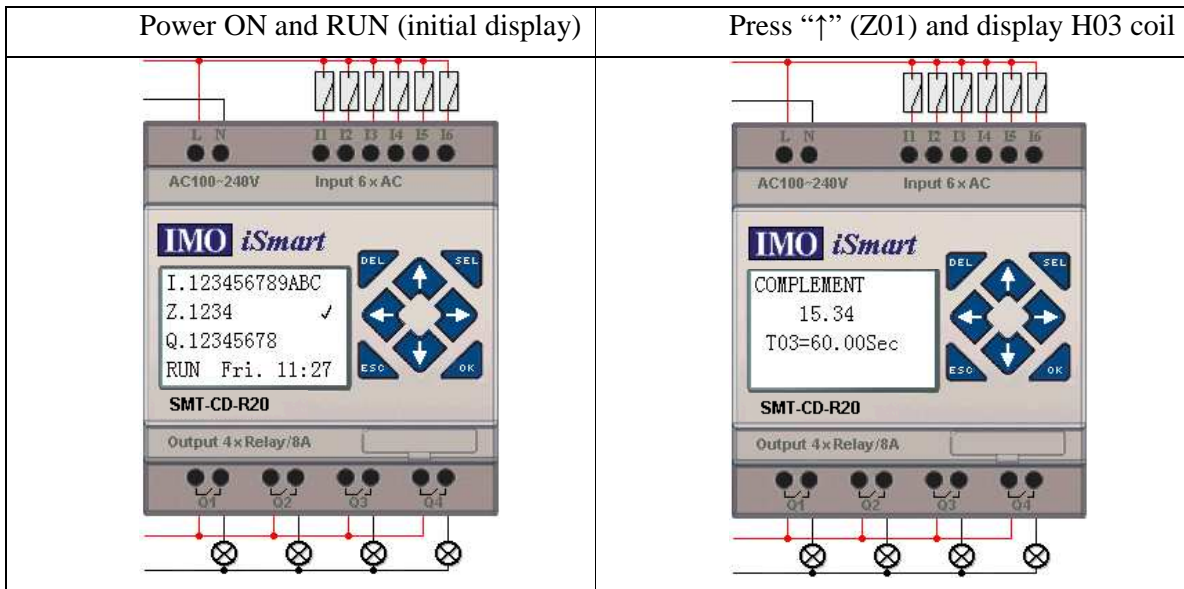

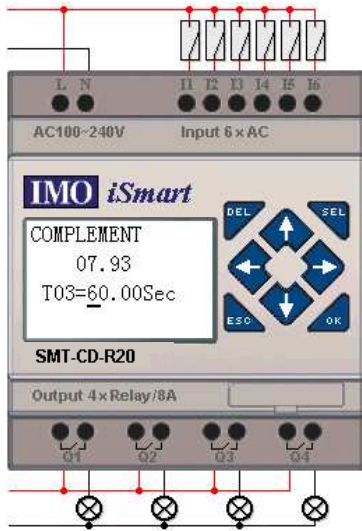

- ① Press “SEL” to display cursor
- ② Press “↑”, “↓”, “←”, “→” to move cursor
- ③ Press “SEL” again to choice modified position
- ④ Press “↑”, “↓” to change number and press “←”, “→” to move cursor
- ⑤ Press “OK” to make sure the modify value

Press “←” (Z02) to disable H03 coil, initial frame.

Press “↓” to reset Timer designed.

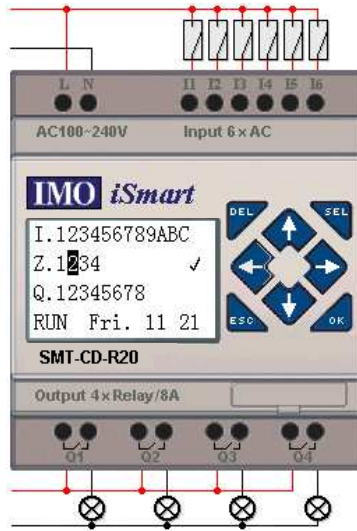

and the LCD display changes to

(T01、 T02、 T03) as program

## Program Documentation

The SMT Client software includes the ability to document a program using Symbols and Line Comments. Symbols are used to label each I/O address up to a length of 12 characters. Line Comments are used to document sections of a program. Each Line Comment can have up to 4 lines with each line containing up to 50 characters in length. Below are examples of entering Symbols and Line Comments.

### Symbol...

The Symbol editing environment can be accessed through the menu using the **Edit>>symbol...** selection or using the symbol icon on the main toolbar shown below.

The Symbol editing environment allows for documenting all the contact and coil memory types, and selecting display modes as shown below.

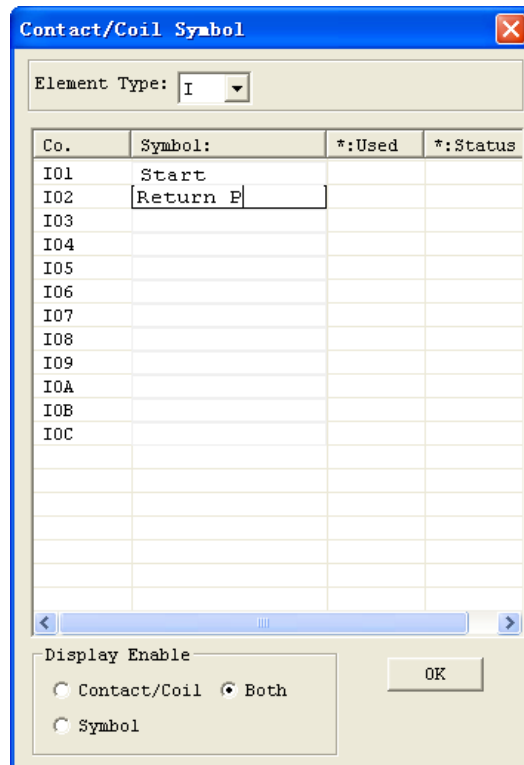
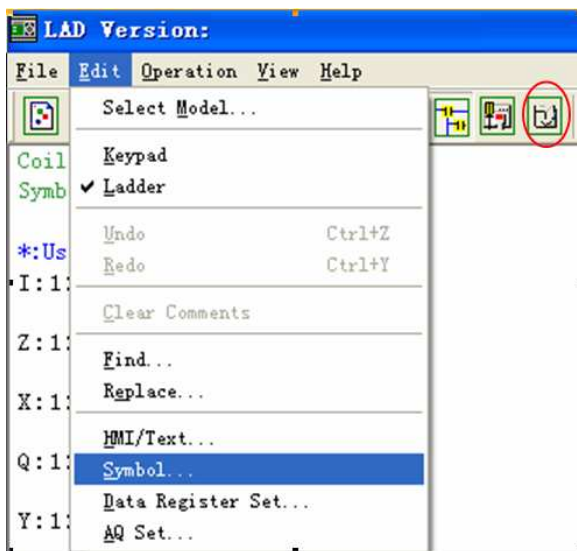

## Line Comments

The Line Comment editor is accessed by clicking the “N” icon on the Ladder Toolbar. After clicking on the “N” icon, to drag the line number you want to comment and release, and then type the desired comments and press OK.

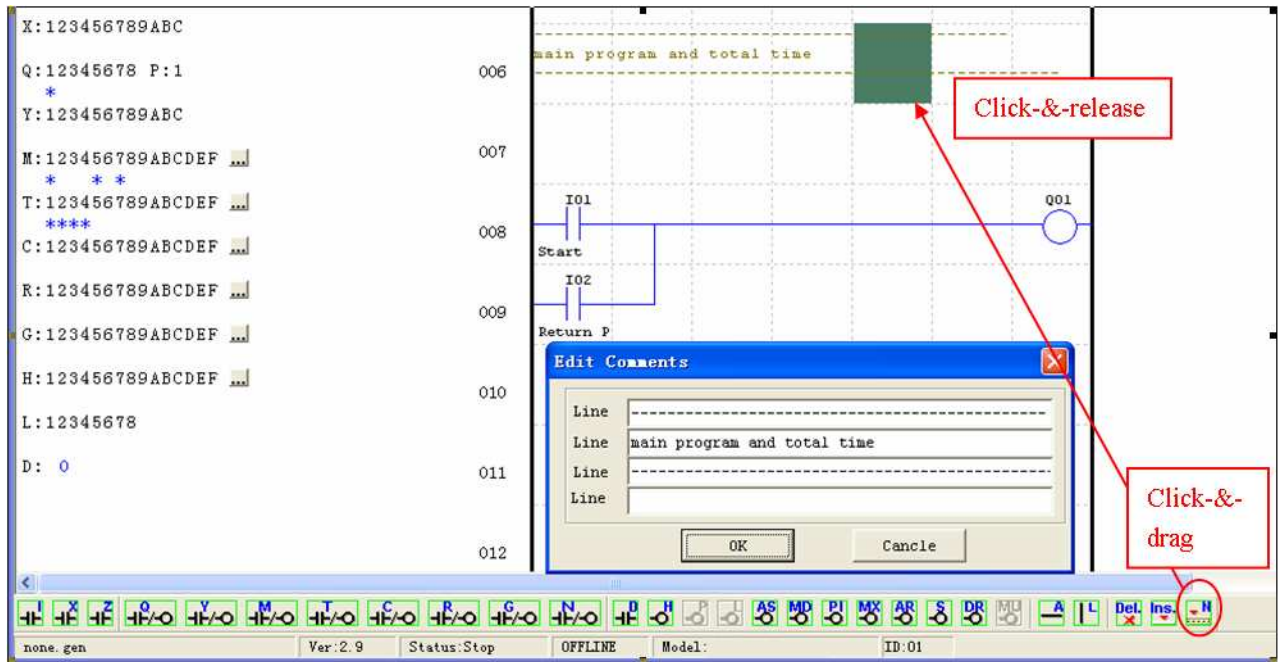

## AQ Set...

The AQ editing environment can be accessed through the menu using the **Edit>> AQ Set...** selection shown below. The range of AQ is 0~1000 if the output mode of AQ is voltage mode. And the range is 0~500 if the output mode is current mode. The preset value of AQ can be set as either a constant or a function of other data. The output mode of AQ and preset value are set as below. More information about output mode and displaying to see: Chapter 4: Relay Ladder Logic Programming

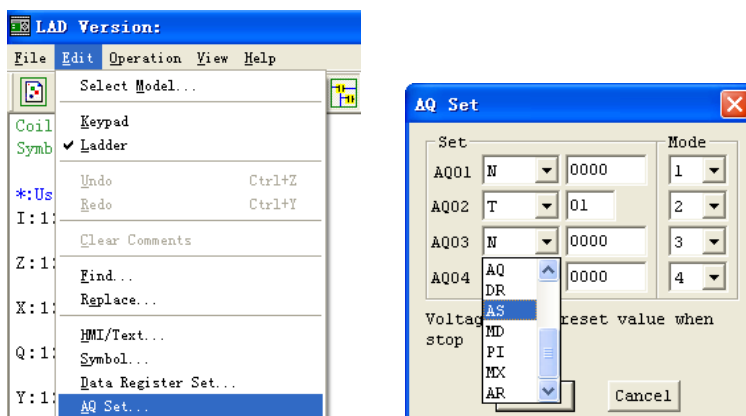

## Data Register Set...

The content of Data Register is either unsigned or signed, it can be set as shown below. Selecting Unsigned, the range of DR is 0~65535; and selecting Signed, the range of DR is -32768~32767.

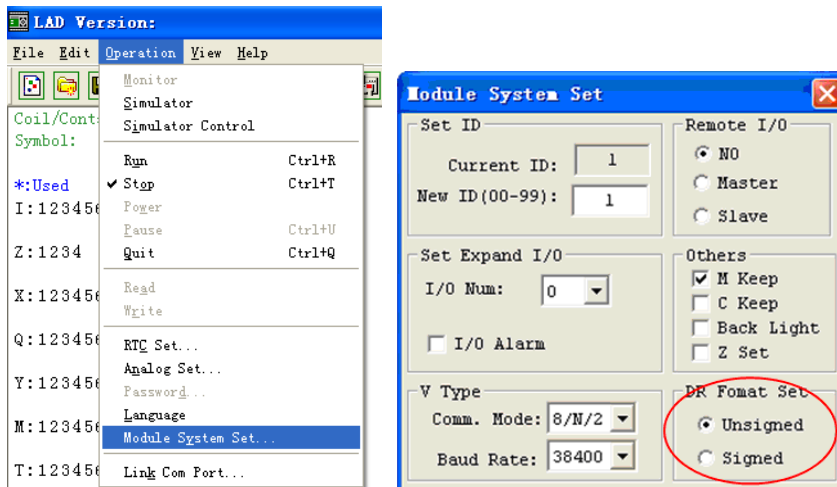

After the operating above, the Data Register editing environment can be access through the menu using the **Edit>> Data Register Set...** selection shown below. The preset value of DR can be set as either a constant or a code of other data type.

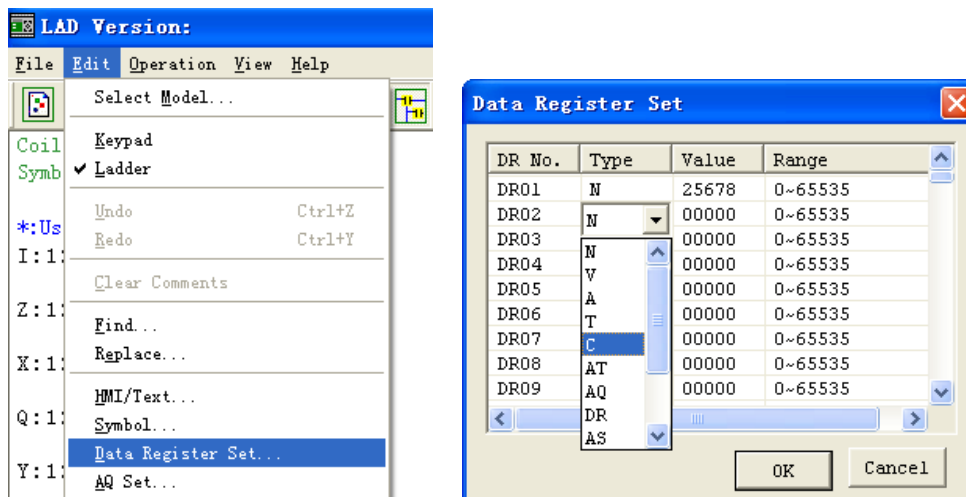

DR is set as signed shown below.

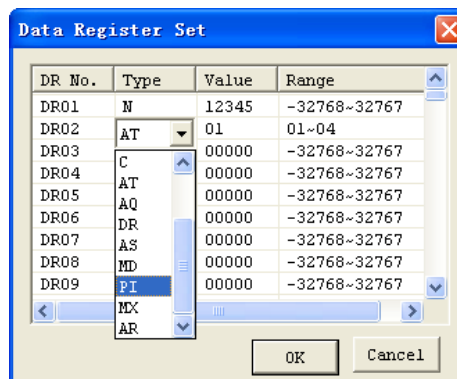

### Memory Cartridge (sold separately)

PM04 (3rd) is a special kind of PM04, it can be used in all version of SMT. There is an icon 3rd on SMT V3 smart and side of PM04 (3rd).

About to use PM04 and PM04 (3rd) with SMTV2/3, see next figure:

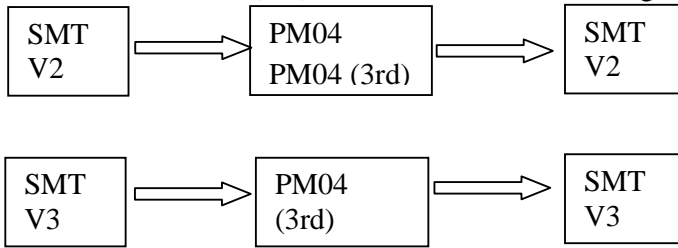

The optional PM04 (3rd) memory cartridge is used to easily transfer programs from one smart relay to another. The PM04 (3rd) memory cartridge plugs into the same connector as the programming cable (see procedure below).

1. Remove the plastic connector cover from SMT using a flathead screwdriver as shown in the figure below.
2. Insert the PM04 (3rd) memory cartridge onto the connector as shown below.

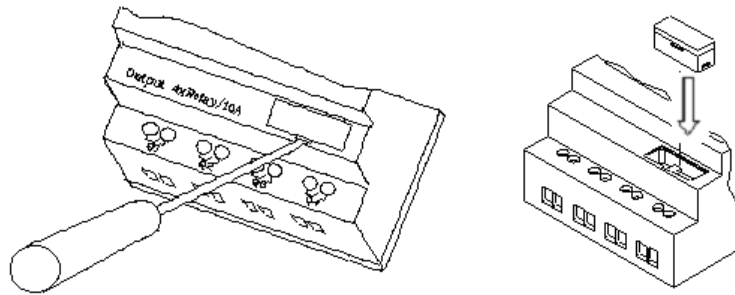

3. From the display keypad on the face of the *i*Smart relay, select either **WRITE** or **READ** to transfer the program to PM04 (3rd) or from the PM04 (3rd) memory cartridge to the smart relay.
4. B type - power the product, the program in PM04 (3rd) will automatically download and execute.
5. Program in different types are not compatible, here are the regulations:

- A-1: 10/12 point type program ---- compatible with 20 point type
- A-2: 20 point type program ---- not compatible with 10/12 point type
- B-1: AC type program ---- compatible with DC type
- B-2: DC type program ---- not compatible with AC type
- C-1: Relay type program ---- compatible with Transistor type
- C-2: Transistor type program ---- not compatible with Relay type
- D-1: Not-C type program ---- compatible with C type
- D-2: CD type program ---- not compatible with Non-C type
- E-1: SMTV2 program ---- compatible with SMTV3 type
- E-2: SMTV3 program ---- not compatible with SMTV2 type

## LCD Display and Keypad

### Keypad

Most SMT CPU units include the built-in LCD Display and Keypad. The keypad and display are most often used for changing timer/counter set points, controller mode changes (Run/Stop), uploading/downloading to the PM04 memory cartridge, and updating the RTC (Real Time Clock/Calendar). Although, logic programming can be performed from the keypad and display, it is highly recommended to only perform logic changes using the SMT Client software. Below is an overview of the basic keypad and display functions.

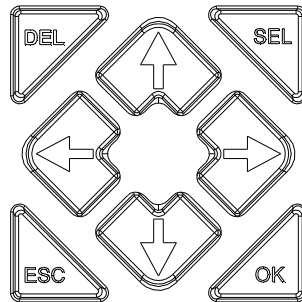

Select (SEL) – Used to select the available memory and instruction types for editing. Holding the Select button will display all “H” HMI/Text messages on the LCD.

OK – Used to accept the selection displayed of an instruction or function. It is also used to select any of the Main Menu options on the LCD.

Note: Press the “SEL” and “OK” simultaneously to insert a rung above the current active cursor position.

Escape – Used to exit a selected display screen and go to the previous screen. When in a ladder display screen, press the ESC to display the main menu.

Delete – Used to delete an instruction or rung from the ladder program.

The 4 navigation buttons (↑←↓→) are used to move the cursor throughout the functions of the SMT display or active program. The 4 buttons also can be set programmable input coils Z01-Z04 (‘↑’= Z01, ‘←’=Z02, ‘↓’=Z03, ‘→’ =Z04);

### Original Screen

LCD displays 4-line state

⊙ Original screen as power on



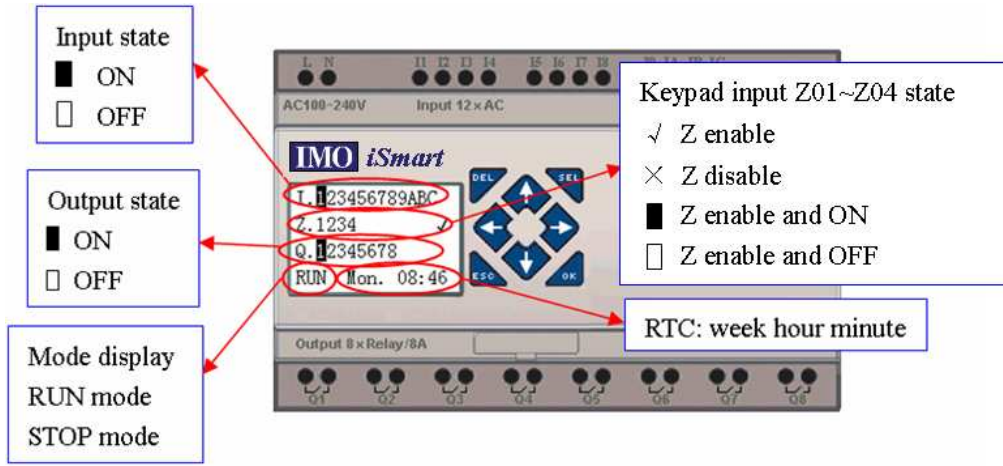

Press the button:

ESC	Enter Main Menu screen
SEL+↑ ↓ ↑ ↓	Under LADDER Mode, display the state of relays (I ↔ Z ↔ Q ↔ X ↔ Y ↔ M ↔ N ↔ T ↔ C ↔ R ↔ G ↔ A ↔ AT ↔ AQ) ↔ Original Screen
	Under FBD Mode, display the state of relays (I ↔ Z ↔ Q ↔ X ↔ Y ↔ M ↔ N ↔ A ↔ AT ↔ AQ) ↔ Original Screen
SEL	H Function will be displayed whose mode is 1 as the button is pressed.
SEL+OK	Enter RTC setting screen

⊙ Expansion display State

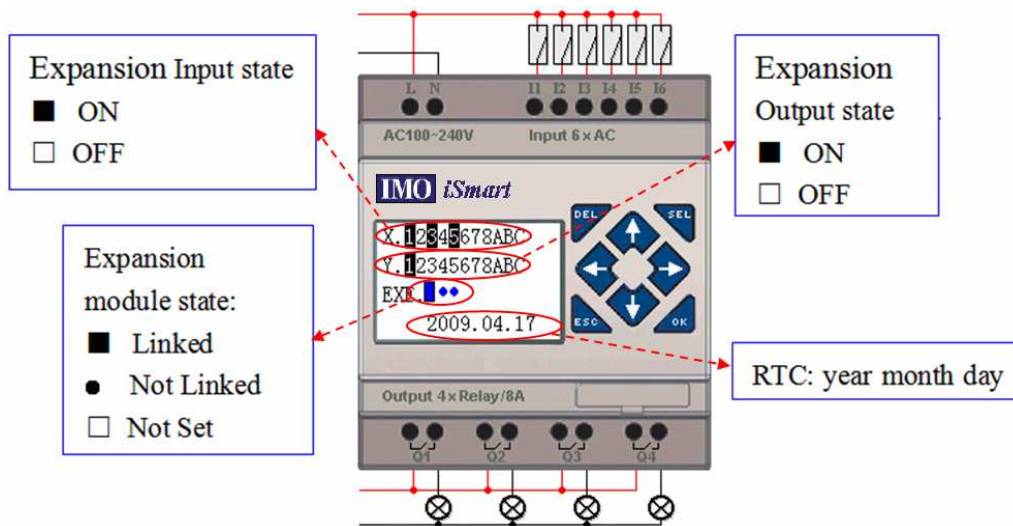

※ Expansion module setting: refer to Main Menu “SET”

⊙ Other Display State

Ladder edit mode: Coil I, Z, X, Q, Y, M, N, T, C, R, G, D, Analogue input A01~A04, Expansion Analogue input A05~A08, temperature analogue input AT01~AT04, analogue output AQ01~AQ04;

FBD edit mode: Coil I, Z, X, Q, Y, M, N, Analogue input A01~A04, Expansion Analogue input A05~A08, temperature analogue input AT01~AT04, analogue output AQ01~AQ04;

Analog input A01~A04 (0~9.99V)      Expansion Analog input A05~A08

A01=00.00V	A05=00.00V
A02=00.00V	A06=00.00V
A03=00.00V	A07=00.00V
A04=00.00V	A08=00.00V

Expansion Analog input A05~A08:  
0~9.99 voltage or 0~20mA current,  
SG2 client software can display  
voltage and current value

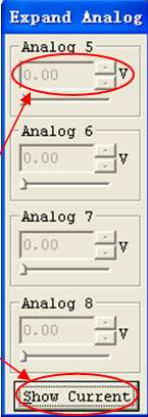

The screenshot shows a vertical stack of four analog input channels labeled 'Analog 5', 'Analog 6', 'Analog 7', and 'Analog 8'. Each channel has a digital display showing '0.00' and a unit indicator 'V'. A red circle highlights the '0.00' display for Analog 5. At the bottom of the stack, there is a button labeled 'Show Current' which is also circled in red. Red arrows point from the text box to the 'Show Current' button and to the '0.00' display of Analog 5.

## LCD Display Main Menu

(1) The Main Menu as SMT under 'STOP' Mode.

Into ladder main function to press ESC after power on when the user program is ladder type or empty program.

Into FBD main function to press ESC after power on when the user program is FBD type or empty program.

>LADDER FUN.BLOCK PARAMETER RUN	>FBD PARAMETER RUN DATA REGISTER
DATA REGISTER CLEAR PROG. WRITE >READ	CLEAR PROG. WRITE READ >SET
SET RTC SET ANALOG SET >PASSWORD	RTC SET ANALOG SET PASSWORD >LANGUAGE
ANALOG SET PASSWORD LANGUAGE >INITIAL	ANALOG SET PASSWORD LANGUAGE >INITIAL

Menu	Description
>	LADDER
LADDER	Ladder edit
FUN.BLOCK	Ladder function block (timer/counter/RTC ...) edit
FBD	FBD display
PARAMETER	FBD block or LADDER function block parameter display
RUN	RUN or STOP
DATA REGISTER	DR display
CLEAR PROG.	Clear the user program and the password
WRITE	Save user program to PM04 (3rd)
READ	Read user Program from PM04
SET	System setting
RTC SET	RTC setting
ANALOGUE SET	Analogue setting
PASSWORD	Password setting
LANGUAGE	Select the language
INITIAL	Initially set Edit method

(2) The Main Menu as SMT under 'RUN' Mode.

>LADDER FUN.BLOCK PARAMETER STOP	>FBD PARAMETER STOP DATA REGISTER	> LADDER	FBD
DATA REGISTER WRITE RTC SET >PASSWORD	WRITE RTC SET PASSWORD >LANGUAGE	FUN.BLOCK	
WRITE RTC SET PASSWORD >LANGUAGE		PARAMETER	
		STOP	
		DATA REGISTER	
		WRITE	
		RTC SET	
		PASSWORD	
		LANGUAGE	

Press the Button

↑ ↓	Move the Cursor to select Main Menu
OK	Confirm the selected Function
ESC	Skip to Initial Screen

※SMT can be modified, edited, cleared and read user program only when it is under STOP Mode.

※As the program is modified, SMT will automatically backup it to FLASH.

◎ Main Menu LADDER

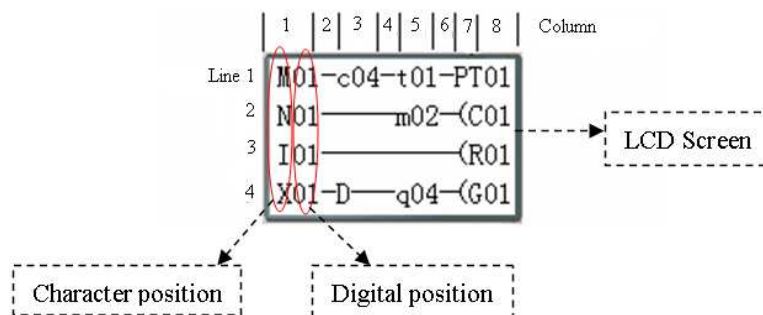

Press the Button

Button	Description
SEL	1. Ixx ⇒ ix x ⇒ — ⇒ space ⇒ Ixx (only for digital and character position of 1, 3, 5 column.) 2. Qxx ⇒ space ⇒ Qxx (only for digital and character position of 8 column.) 3. T ⇒ Space ⇒ T (all available but the 2,4,6 column of the first line) ⊥ ⊥
SEL, then ↑/↓	1. I ⇔ X ⇔ Z ⇔ Q ⇔ Y ⇔ M ⇔ N ⇔ D ⇔ T ⇔ C ⇔ R ⇔ G ⇔ I (When the cursor located at 1, 3, 5 Column). 2. Q ⇔ Y ⇔ M ⇔ N ⇔ T ⇔ C ⇔ R ⇔ G ⇔ H ⇔ L ⇔ P ⇔ S ⇔ AS ⇔ MD ⇔ PI ⇔ MX ⇔ AR ⇔ DR ⇔ MU ⇔ Q (When the cursor located at 8 Column) 3. ( ⇔ ^ ⇔ v ⇔ P ⇔ ( (When the cursor located at 7 Column, and the 8 Column is set as Q, Y, M, N) 4. ( ⇔ P ⇔ ( (When the cursor located at 7 Column, and the 8 Column is set as T)
SEL, then ←/→	Confirm the input data and move the cursor
↑ ↓ ← →	move the cursor
DEL	Delete an instruction
ESC	1. Cancel the Instruction or action under Edition. 2. Back to Main Menu after query the program (save program).
OK	1. Confirm the data and automatically save, the cursor moves to next input position. 2. When the cursor is on Column 8, Press the button to automatically enter the function block and set the parameters(such as T/C).
SEL+DEL	Delete a Line of Instruction.
SEL+ESC	Display the number of the Lines and operation state of SMT (RUN/STOP).
SEL+↑/↓	Skip up/ down every 4-line program.
SEL+OK	Insert a space line

Operation Sample: more detailed to see appendix A.

⊙ FUNCTION BLOCK program input

Into FUNCTION BLOCK, cursor flicker on “T”, press “SEL” key, Ladder function block display in sequence:

T→C→R→G→H→L→P→S→AS→MD→PI→MX→AR→MU→T...

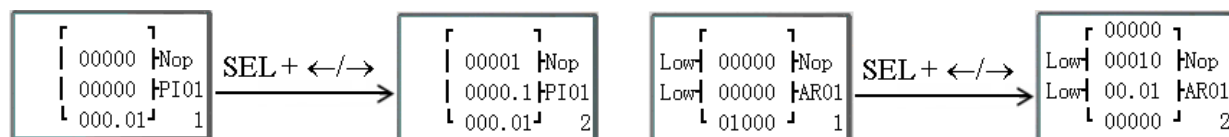
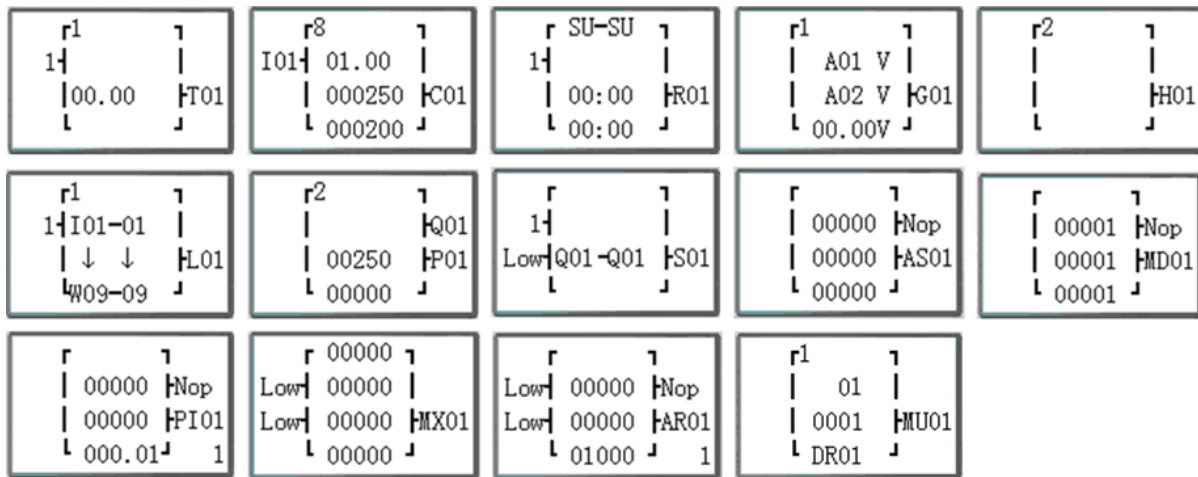

Operation Sample: more detailed to see Appendix B.

⊙PARAMETER

Under Ladder mode, press “SEL” key, function block display in sequence:

T→C→R→G→AS→MD→PI→MX→AR→MU→T...

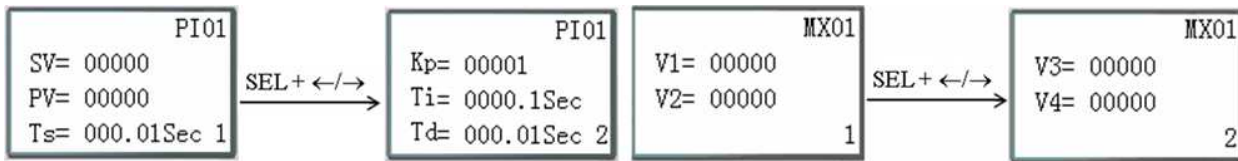
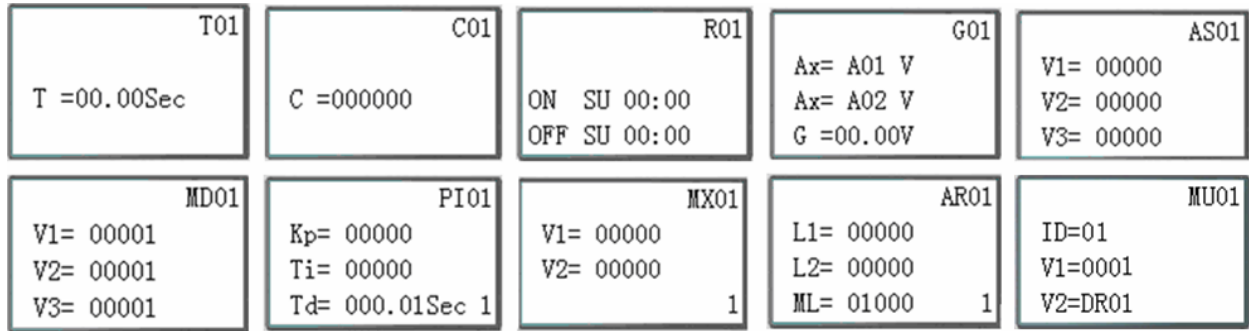

Under FBD mode, Press “SEL” key, Block displays in sequence.

⊙ RUN or STOP

(1) RUN Mode                      (2) STOP Mode



↑ ↓	Move the cursor
OK	Execute the instruction, then back to main menu
ESC	Back to main menu

⊙DATA REGISTER

Displaying preset value when the smart is STOP status and displaying current value when the smart is RUN status.

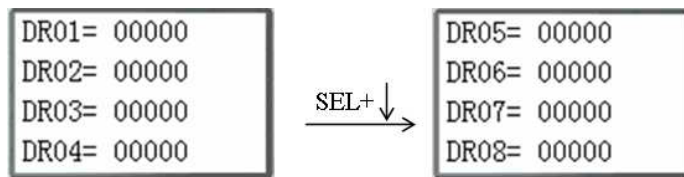

↑ ↓ ← →	Move the cursor
OK	Ensure the edit
SEL	Enter edit (edit DR display number or DR preset value)
‘SEL’ then ‘SEL’	Edit DR preset value type
‘SEL’ then ‘↑ ↓’	1. Edit DR display number (only first line)

	2. Edit DR preset value
ESC	1. Cancel edit. 2. Back to main menu (save DR preset data)
SEL+↑/↓	Tip-up/down page

◎ Other Menu Items

(1) CLEAR PROGRAM (Clear RAM, EEPROM and Password at the same time)



(2) WRITE: save the program (RAM) to PM04 (3rd) program spare cartridge

(3) READ: read the program from the PM04 or PM04 (3rd) program spare cartridge to SMT (RAM)



(1) ~ (3) Now Press:

↑ ↓	Move the cursor
OK	Execute the instruction
ESC	Back to main menu

(4) SET (system setting)

	Content	Default	
ID SET 01	ID SET	01	→ ID setting (00~99)
REMOTE I/O N	REMOTE I/O	N	→ Remote I/O Mode (N: none M: Master S: Slave)
BACKLIGHT x	BACK LIGHT	×	→ Back light mode (√: always light ×: light for 10s after pressed.)
M KEEP ✓	M KEEP	√	→ M: non-Volatile (√:Volatile ×: Non- Volatile)
I/O NUMBER: 0	I/O NUMBER	0	→ Setting expansion I/O module number (0~3)
I/O ALARM ✓	I/O ALARM	√	→ Siren setting when is not available to Expansion I/O Points (√:Yes ×:No)
C KEEP x	C KEEP	×	→ in stop/run switching, Counter Present Value Keeping (√:Yes ×:No)
Z SET x	Z SET	×	→ Enable or disable keypad input Z01-Z04 (√:enable ×:disable)
V COMM SET 03	V COMM SET	03	→ Setting the form and baud rate of RS-485
DATA REG. U	DATA REG.	U	→ Setting the Data Register type (U: 16bit-unsiged S: 16bit-sign)

※ M KEEP function is available for keeping M status and current value of T0E/T0F when power is re-supplied after loss.

Now Press:

↑↓←→	Move the cursor
SEL	Begin to edit.
'SEL' then '←/→'	Move the cursor for 'ID SET' item and 'V COMM SET' item
'SEL' then '↑/↓'	1. ID SET = 00~99 ; I/O NUMBER = 0~3 2. REMOTE I/O = N↔M↔S↔N 3. BACK LIGHT ; C KEEP ; Z SET = ×↔√ 4. M KEEP; I/O ALARM = √↔× 5. V COMM SET = (0~3)(0~5) 6. DATA REG. = U↔S
OK	Confirm the Edition Data
ESC	1. Cancel the setting when pressed 'SEL' 2. Back to Main Menu(save edit data)

※ When DATALINK is selected, ID setting range is 0~7, which should be continuous.

ID=0 default as Master, ID=1~7 default as Slave.

※ When REMOTE I/O is selected, the distribution of the remote I/O is as follows:

	Master		Slave
Remote Input	X01~X0C	←	I01~I0C
Remote Output	Y01~Y08	→	Q01~Q08

※ The high bit of V COMM SET detects the form of RS-485, and the low bit detects the baud rate of RS-485.

More detailed to see chapter 4: Relay Logic Programming: Data Link/Remote IO Instruction

#### (5) RTC SET

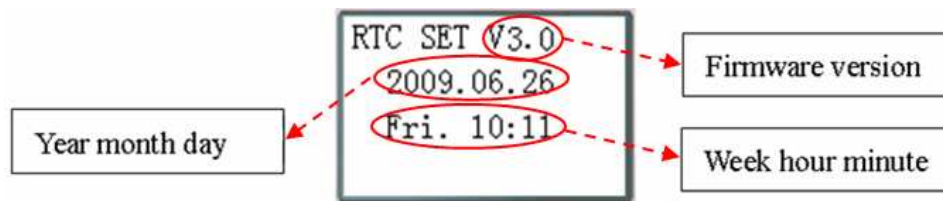

Now Press

↑↓	Enter RTC setting or Summer/Winter setting
SEL	Begin to input parameters
'SEL' then '←/→'	Move the Cursor
'SEL' then '↑/↓'	1. year=00~99, month=01~12, day=01~31 2. week: MO↔TU↔WE↔TH↔FR↔SA↔SU↔MO 3. hour = 00~23 , minute = 00~59
'SEL' then 'SEL'	Summer/Winter setting: NO – EUROPE – USA – OTHER – NO ...
OK	Save the Input Data
ESC	1. Cancel the Input Data when press 'SEL'. 2. Back to Main Menu.

※ RTC precision

Temperature	Error
+25°C	±3s/day
-20°C/+50°C	±6s/day



## RTC Summer/Winter setting

There are 2 fixed Summer/Winter, EUROPE and USA, 1 edit Summer/Winter in SMT.

Edit rule: ①The last Sunday is defined as 0;

②Hour range: 1~22;

③Summer hour and Winter hour are the same.

Summer/Winter can be set through the two methods as shown below.

### 1) PC Client

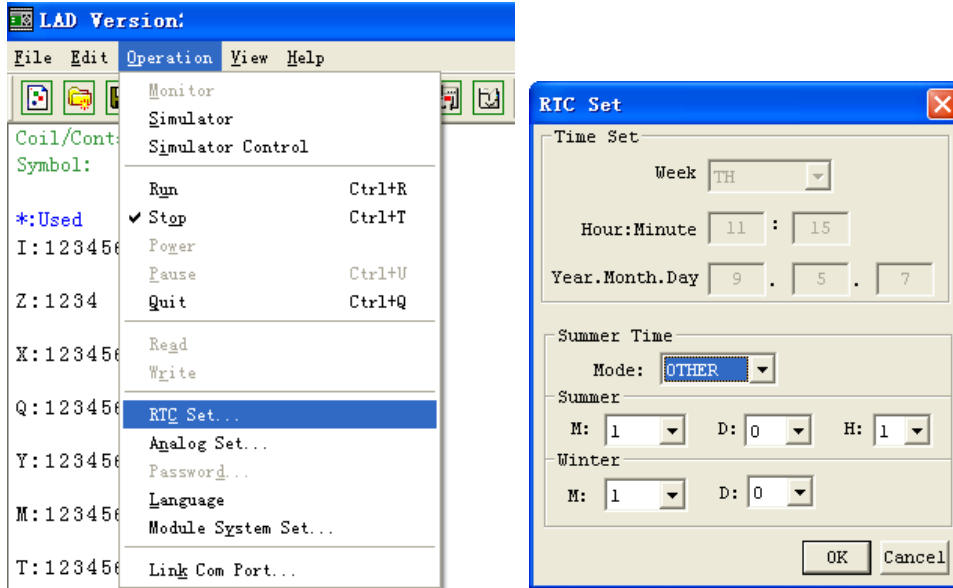

### 2) Keypad

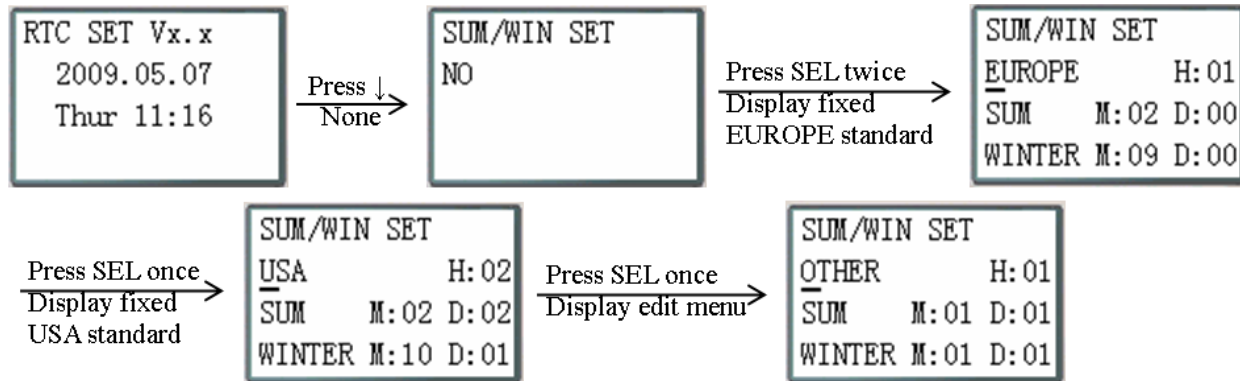

Then pressing “→” selects edit location, pressing “↑”, “↓” edit content.

### Example:

Year 2009, SUM M: 05 D: 01 → 2009-5-3; M: 10 D: 00 → 2009-10-25.

```

SUM/WIN SET
OTHER      H: 08
SUM       M: 05 D: 01
WINTER   M: 10 D: 00

```

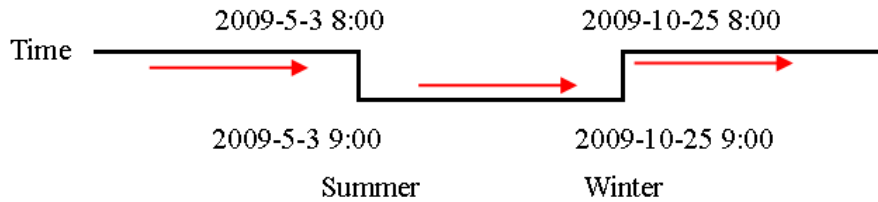

(6) ANALOGUE SET

```

A01=GAIN  :010
  OFFSET:+00
A02=GAIN  :010
  OFFSET:+00

```

```

A 1=GAIN : 010
OFFSET : +00
A 2=GAIN : 010
OFFSET : +00
A3~A8...Gain +
Offset

```

→ GAIN (0~999), default 10  
 → OFFSET (-50~+50), default 0

Now Press

↑ ↓	1. Move downward the Cursor 2. Switch the setting screen from A01/A02 → A03/A04 → A50/A06 → A07/A08
SEL	Begin to input parameters
'SEL' then '←/→'	Move the Cursor
'SEL' then '↑/↓'	1. GAIN =000~999 2. OFFSET=-50~+50
OK	Save the Input Data
ESC	1. Cancel the Input Data when press 'SEL'. 2. Back to Main Menu (save edit data).

※  $V01 = A01 * A01\_GAIN + A01\_OFFSET \dots V08 = A08 * A08\_GAIN + A08\_OFFSET$

(7) PASSWORD (setting password)

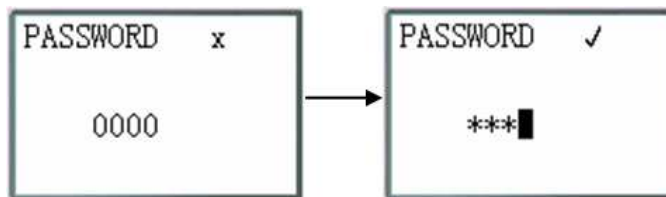

Now Press

SEL	1. Begin to input numeral 2. When the password is ON, it will not display 0000, but ****.
'SEL' then '←/→'	Move the cursor
'SEL' then '↑/↓'	Data changed 0~F
OK	Save the input data, not 0000 or FFFF, as the PASSWORD is ON.
ESC	1. Cancel the Input Data when press 'SEL'. 2. Back to Main Menu.

※ A Class: Password number is set to 0001~9FFF.

B Class: Password number is set to A000~FFFE.

Password number = 0000 or FFFF is disabled Password function, Default setting: 0000.

A/B Class password Description (√ : cannot use under password protected )

Menu	A Class	B Class
LADDER	√	√
FUN.BLOCK	√	√
FBD	√	√
PARAMETER		√
RUN/STOP		√
DATA REGISTER		√
CLEAR PROG.	√	√
WRITE	√	√
READ	√	√
SET		√
RTC SET		
ANALOGUE SET		√
LANGUAGE		√
INITIAL	√	√

(8) LANGUAGE (Selection menu language)

>ENGLISH ✓ FRANÇAIS ESPAÑOL ITALIANO	→ English
	→ French
	→ Spanish
	→ Italian
ITALIANO DEUTSCH PORTUGUES >简体中文	→ German
	→ Portuguese
	→ Simplified Chinese

Now Press

↑↓	Vertically move the Cursor
OK	Select the language the cursor located
ESC	Back to Main Menu

(9) INITIAL (select Ladder Logic and Function Block Diagram (FBD))

INITIAL  >LADDER ✓ FBD
---------------------------------

Now Press:

↑↓	Vertically move the Cursor
OK	Select the mode the cursor located
ESC	Back to Main Menu



The origin program will be cleared as the change of edition method.

## Chapter 4: Relay Ladder Logic Programming

### Common Memory Types

	General output	SET output	RESET output	PULSE output	N.O. contact	N.C. contact	Number
<b>Symbol</b>	[	▲	▼	P	⏏	⏏	(N.O./N.C.)
<b>Input contact</b>					I	i	12(I01-I0C/i01-i0C)
<b>Keypad input</b>					Z	z	4(Z01-Z04/z01-z04)
<b>Output coil</b>	Q	Q	Q	Q	Q	q	8(Q01-Q08/q01-q08)
<b>Auxiliary relay</b>	M	M	M	M	M	m	63(M01-M3F/m01-m3F)
<b>Auxiliary relay</b>	N	N	N	N	N	n	63 (N01-N3F/n01-n3F)
<b>Counter</b>	C				C	c	31(C01-C1F/c01-c1F)
<b>Timer</b>	T			T	T	t	31(T01-T1F/t01-t1F)

#### Inputs (I memory Type)

The SMT digital input points are designated I memory types. The number of digital I input points is 6, 8 or 12 depending on each SMT model.

#### Keypad inputs (Z Memory type)

The SMT keypad input points are designated Z memory types. The number of digital Z input points is 4 depending on SMT B type model and C type model.

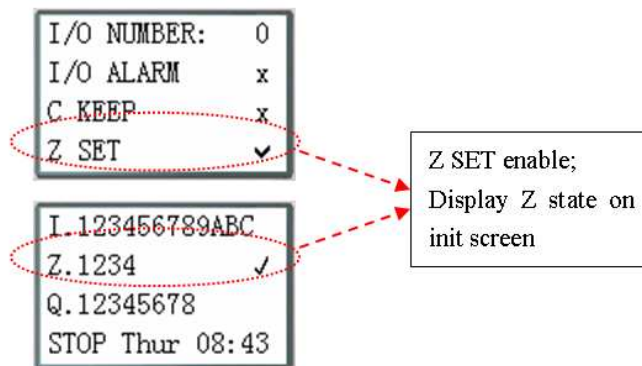

### Outputs (Q Memory Type)

The SMT digital output points are designated Q memory types. The number of digital Q output points is 4 or 8 depending on each SMT model. In this example, output point Q01 will be turned on when input point I01 is activated.

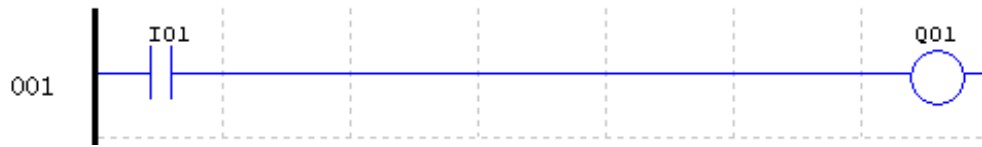

### Auxiliary Relays (M memory type)

Auxiliary relays are digital internal memory bits used to control a ladder logic program. The auxiliary relays are not physical inputs or outputs that can be wired to any external device, switches, sensors, relays, lamps, etc. The number of Auxiliary Relays M is 63. Since auxiliary relays are internal bits within the CPU, they can be programmed as digital inputs (contacts) or digital outputs (coils). In the first rung of this example, auxiliary relay M01 is being used as an output coil and will energize when input I02 turns on. In the second rung auxiliary relay M01 is being used as an input and when energized, will turn on outputs Q02 and Q03.

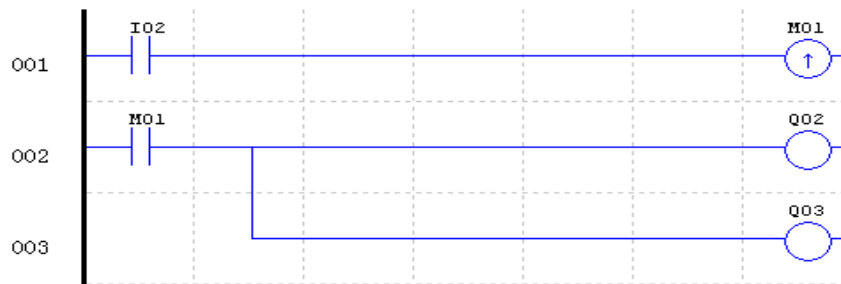

※ The state of auxiliary relays “M01~M3F” will be kept when the smart powers down if “M Keep” is active. “M Keep” can be set by the two ways below.

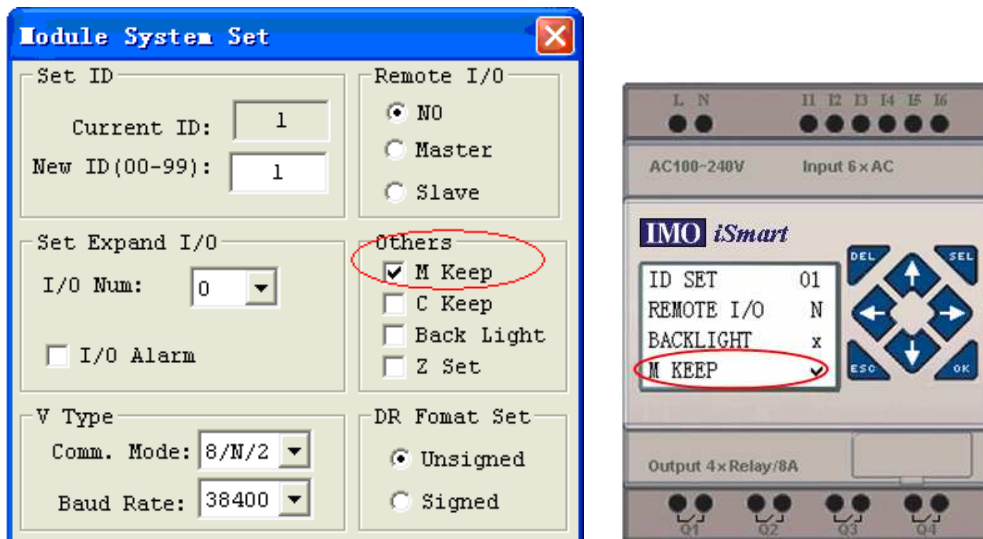

### Special Auxiliary Relays: M31~M3F

Code	Signification	Description
M31	User program upstart flag	Outputting ON during the first scanning period; and used as normal auxiliary relay at other scan period.
M32	1s blinking output	0.5s ON, 0.5s OFF
M33	Summer/Winter output	Summer time turn ON, winter time turn OFF, used as normal auxiliary relay.
M34	AT01 flag	Output ON when the first channel of SMT-4PT is error
M35	AT02 flag	Output ON when the second channel of SMT-4PT is error
M36	AT03 flag	Output ON when the third channel of SMT-4PT is error
M37	AT04 flag	Output ON when the fourth channel of SMT-4PT is error
M38~M3C	reserved	
M3D	Received	MODBUS function flags
M3E	Error flag	
M3F	Time out	

### Auxiliary Relays (N memory type)

Auxiliary relays N is the same to auxiliary relays M, but it can't be kept when the smart powers down.

In the first rung of this example, auxiliary relay N01 is being used as an output coil and will energize when input I03 turns on. In the second rung auxiliary relay N01 is being used as an input and when energized, will turn on outputs Q04 and Q05.

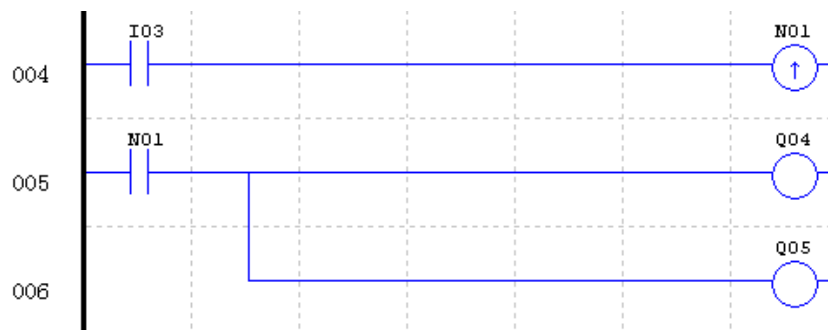

### Timers and Timer Status Bits (T Memory Type)

Timer status bits provide the relationship between the current value and the preset value of a selected timer. The timer status bit will be on when the current value is equal or greater than the preset value of a selected timer. In this example, when input I03 turns on, timer T01 will start. When the timer reaches the preset of 5 seconds timer status contact T01 turns on. When T01 turns on, output Q04 will turn on. Turning off I03 will reset the Timer.

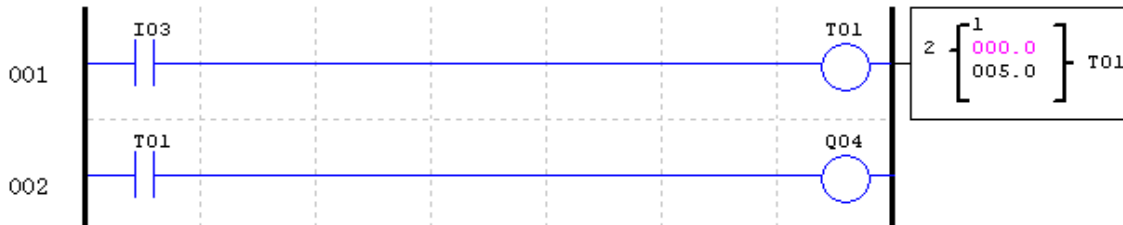

### Counters and Counter Status Bits (C Memory Type)

Counter status bits provide the relationship between the current value and the preset value of a selected counter. The counter status bit will be on when the current value is equal or greater than the preset value of a selected counter. In this example, each time the input contact I04 transitions from off to on, the counter (C01) increments by one. When the counter reaches the preset of 2 counts, the counter status contact C01 turns on. When C01 turns on, output Q05 will turn on. When M02 turns on counter C01 will reset. If M09 is turned on, the counter will change from a count-up to a count-down counter.

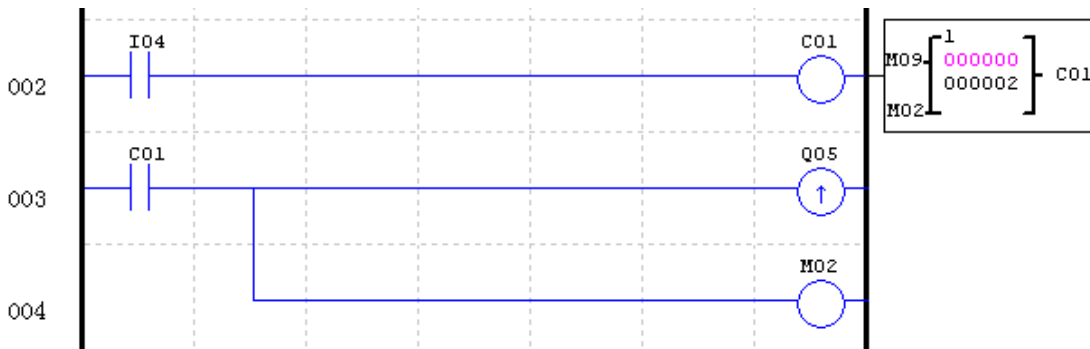

### Specialty Memory Types

	General output	SET output	RESET output	PULSE output	N.O. contact	N.C. contact	Number
Symbol	[	▲	▼	P	⎓	⎓/	(N.O./N.C.)
					Lo	Hi	Used in function block
Expansion input coil					X	x	12(X01-X0C/x01-x0C)
Expansion output coil	Y	Y	Y	Y	Y	y	12(Y01-Y0C/y01-y0C)
Differential (one shot)					D	d	
RTC	R				R	r	31(R01-R1F/r01-r1F)
Analogue comparator	G				G	g	31(G01-G1F/g01-g1F)
HMI	H						31(H01-H1F)
PWM	P						2(P01-P02)
DATA LINK	L						8(L01-L08)
SHIFT	S						1(S01)

### Positive input Differential Instruction (One-Shot)

A positive input differential instruction, or One-Shot, holds its status ON for one CPU scan when the preceding series contact transitions from OFF to ON. This transition from OFF to ON is called a Positive Input Differential.

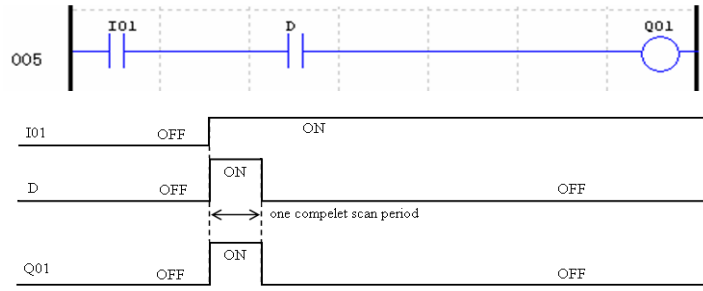

### Negative Input Differential Instruction (One-Shot)

A negative input differential instruction, or One-Shot, holds its status ON for one CPU scan when the preceding series contact transitions from ON to OFF. This transition from ON to OFF is called a Negative Input Differential.

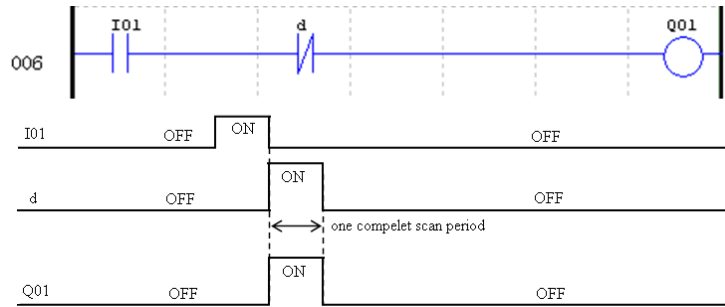



## Output Instructions

### Set Output Instruction (Latch) (A)

A set output instruction, or Latch, turns ON an output coil (Q) or an auxiliary contact (M) when the preceding input contact transitions from OFF to ON. Once the output is ON or set, it will remain ON until it is reset using the Reset output instruction. It is not necessary for the preceding input contact controlling the Set output instruction to remain ON.

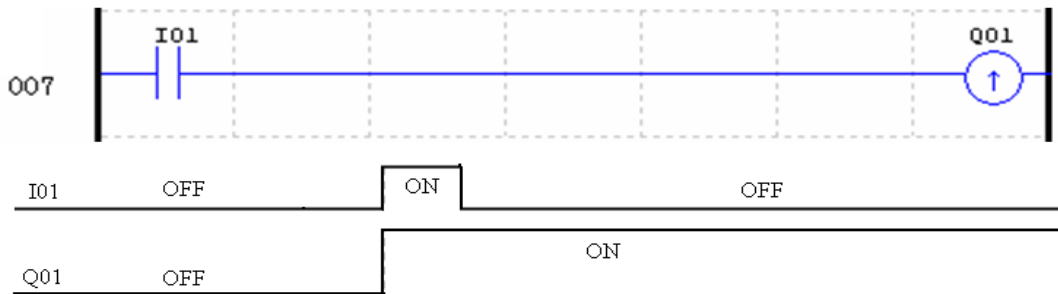

### Reset Output Instruction (Unlatch) (V)

A reset output instruction, or Unlatch, turns OFF a previous set output coil (Q) or an auxiliary contact (M) when the preceding input contact transitions from OFF to ON. Once the output is OFF or reset, it will remain OFF until it is reset using another output instruction. It is not necessary for the preceding input contact controlling the Reset output instruction to remain ON.

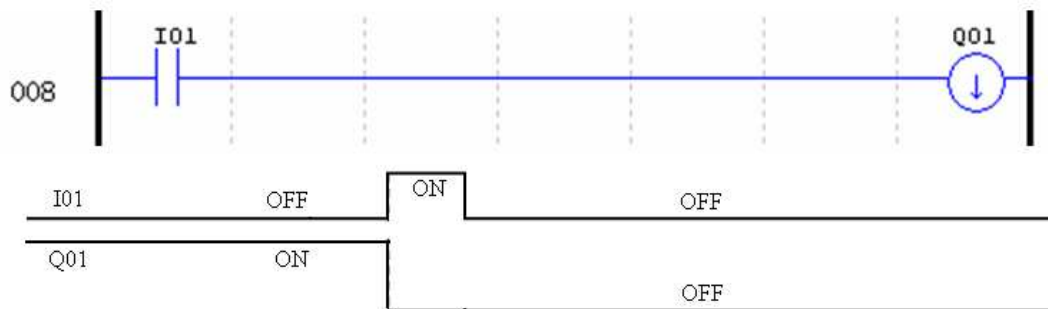

## Pulse Output Instruction (Flip-Flop) (P)

A pulse output instruction, or Flip-Flop, turns ON a coil (Q) or an auxiliary contact (M) when the preceding input contact transition from OFF to ON. Once the output is ON, it will remain ON until the preceding input contact transitions from OFF to ON a second time. In the example below, when Pushbutton I03 is pressed and released Motor Q04 will turn on and remain on. When Pushbutton I03 is pressed again, Motor Q04 will turn off and remain off. The pulse output instruction (P) will “flip-flop” its state from ON to OFF at each press of Pushbutton I03.

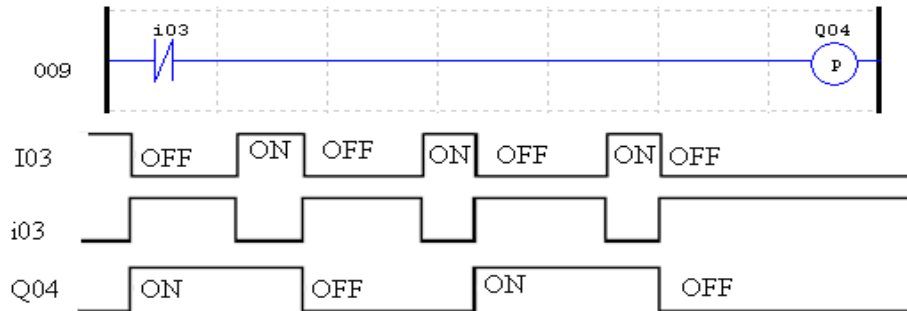

## Analogue memory type

	Analogue input	Analogue output	Number
Analogue input	A		8 (A01~A08)
Analogue input parameter	V		8 (V01~V08)
Temperature input	AT		4 (AT01~AT04)
Analogue output		AQ	4 (AQ01~AQ04)
Add-Subtract control	AS	AS	31 (AS01~AS1F)
Multiply-Divide control	MD	MD	31 (MD01~MD1F)
PID control	PID	PID	15 (PI01~PI0F)
Data Multiplexer control	MX	MX	15 (MX01~MX0F)
Analogue Ramp control	AR	AR	15 (AR01~AR0F)
Data Register	DR	DR	240 (DR01~DRF0)
MODBUS			15 (MU01~MU0F)

Analogue value (A01~A08, V01~V08, AT01~AT04, AQ01~AQ04) and current value of functions (T01~T1F, C01~C1F, AS01~AS1F, MD01~MD1F, PI01~PI0F, MX01~MX0F, AR01~AR0F, and DR01~DRF0) can be used as other function’s preset value. And the parameter preset value is its limit value when the current value of those functions is bigger or less than parameter’s limit value.

### Timer Instruction

The SMT includes a total of 31 separate Timers that can be used throughout a program. T0E and T0F keep their current value after a loss of power to the smart relay if “M Keep” is active, but the other Timers’ current value is non-retentive. Each Timer has a choice of 8 operation modes, 1 for a pulse Timer and 7 for general purpose Timer. Additionally, each Timer has 6 parameters for proper configuration. The table below describes each configuration parameter and lists each compatible memory type for configuring Timers.

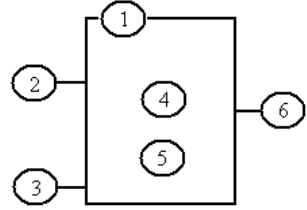

Symbol	Description
①	Timer Mode (0-7)
②	Timer Unit 1: 0.01s, range: 0.00 - 99.99 sec 2: 0.1s, range: 0.0 - 999.9 sec 3: 1s, range: 0 - 9999 sec 4: 1min, range: 0 - 9999 min
③	ON: the Timer reset to 0 OFF: the Timer continues timing
④	Timer current value
⑤	Timer preset value
⑥	Timer code(T01~T1F total: 31 Timers)

Compatible Instructions	Range
<b>Input</b>	I01-I0C/i01-i0C
<b>Keypad input</b>	Z01-Z04/z01-z04
<b>Output</b>	Q01-Q08/q01-q08
<b>Auxiliary coil</b>	M01-M3F/m01-m3F
<b>Auxiliary coil</b>	N01-N3F/n01-n3F
<b>Expansion input</b>	X01-X0C/x01-x0C
<b>Expansion output</b>	Y01-Y0C/y01-y0C
<b>RTC</b>	R01-R1F/r01-r1F
<b>Counter</b>	C01-C1F/c01-c1F
<b>Timer</b>	T01-T1F/t01-t1F
<b>Analogue comparator</b>	G01-G1F/g01-g1F
<b>Normal close contact</b>	Hi

- ※ The preset value of Timer could be a constant or other function current value.
- ※ The current value of T0E and T0F will be kept after a loss of power if the “M-Keep” is active.

## Timer Mode 0 (Internal Coil)

Mode 0 Timer (Internal Coil) used as internal auxiliary coils. No timer preset value. The status of T coil becomes with enable coil as shown below.

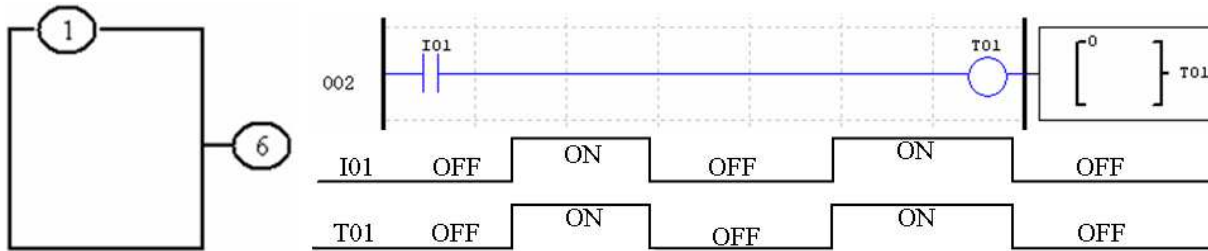

※ I01 is enable coil.

## Timer Mode 1 (ON-Delay)

Mode 1 Timer (ON-Delay) will time up to a fixed value and stop timing when the current time is equal to the preset value. Additionally, the Timer current value will reset to zero when Timer is disabled. In the example below, the timer will stop timing when it reaches the preset value of 5 seconds. Timer status bit T01 will be ON when the current value is 5.

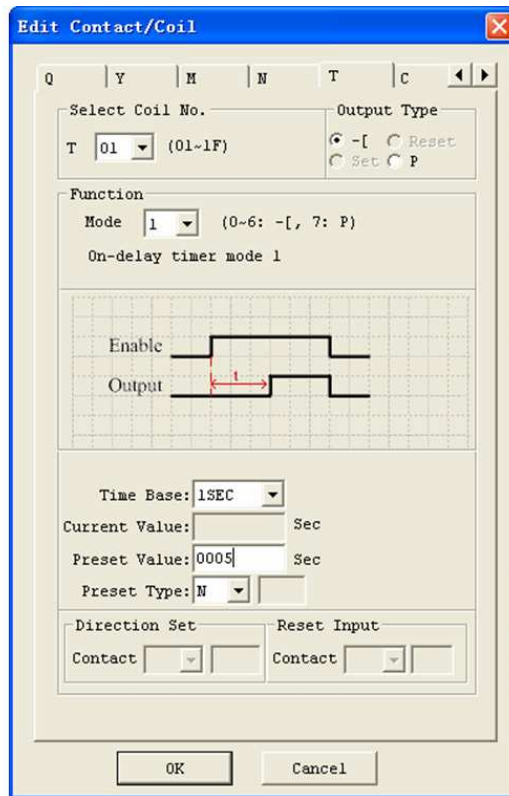
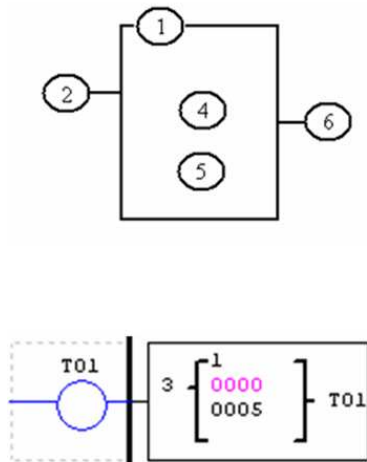

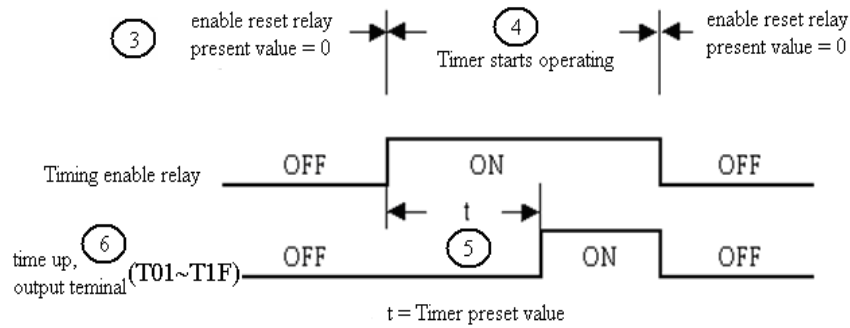

✘ T0E and T0F keep their current value after a loss of power to the smart relay if “M Keep” is active, but the others’ reset to 0.

### Timer Mode 2 (ON-Delay with Reset)

Mode 2 Timer is an ON-Delay with reset that will time up to a fixed preset value and stop timing when the current time is equal to the preset value. Additionally, the Timer current value will be kept when Timer is disabled. In the example below, the Timer will stop timing when it reaches its preset value of 5 seconds. Timer status bit T01 will be ON when the current value is 5. The timer reset input is input I01. The timer current value will reset to 0, and Timer status bit T01 will turn off when I01 is ON.

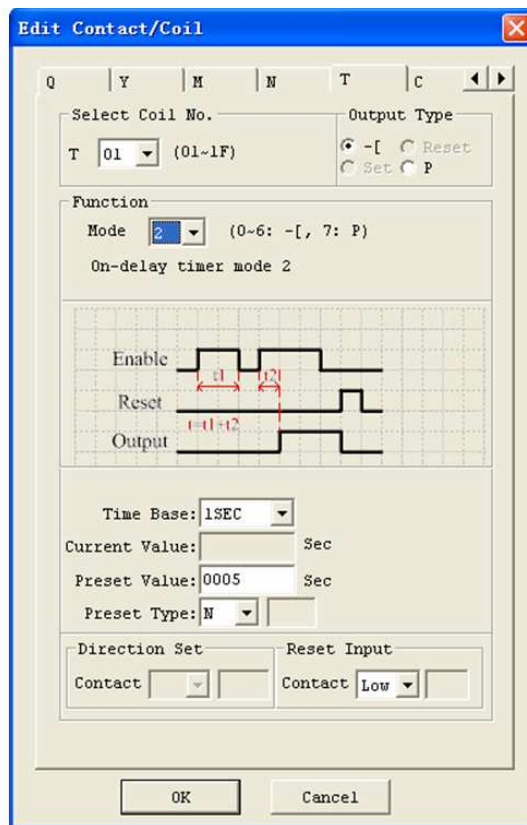
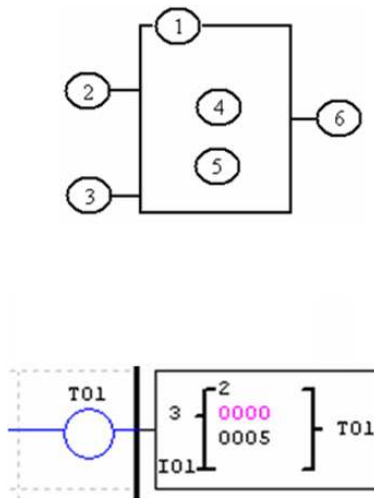

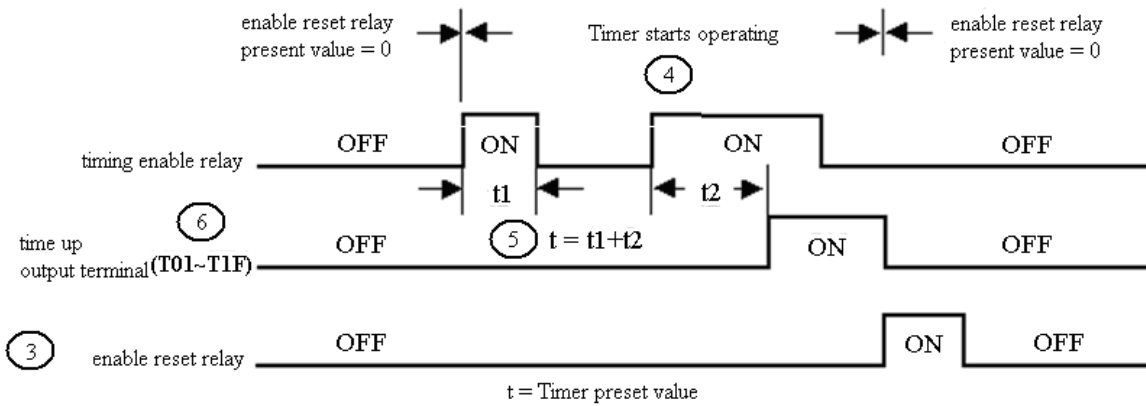

※ TOE and TOF keep their current value after a loss of power to the smart relay if “M Keep” is active, but the others’ reset to 0.

### Timer Mode 3 (OFF-Delay)

Mode 3 Timer is an OFF-Delay with reset that will time up to a fixed preset value and stop timing when the current time is equal to the preset value. Additionally, the Timer current value will reset to zero when Timer is disabled. In the example below, the timer reset input is Input I01. Timer status bit T01 will be ON immediately when its rung is true. The timer will only begin timing up when its rung changes to false. Timer status bit T01 will turn OFF when the current time value reaches its preset value of 10 seconds.

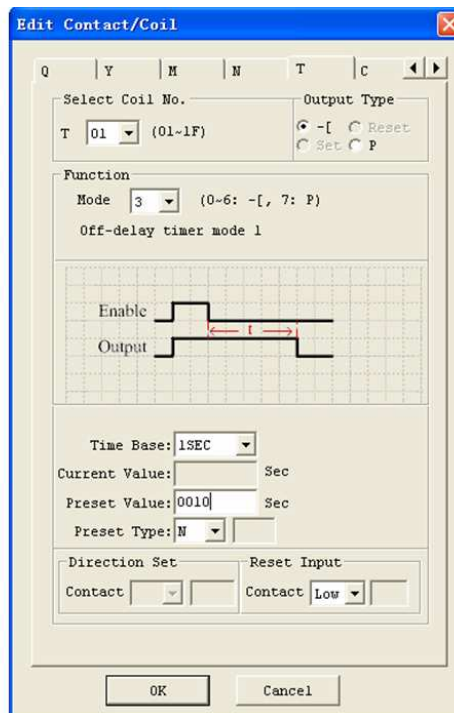
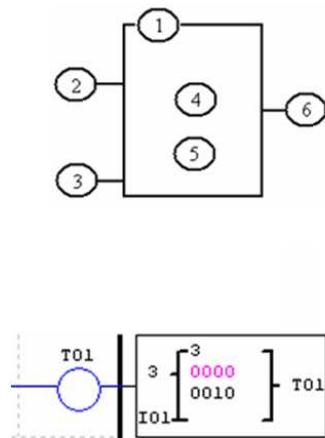

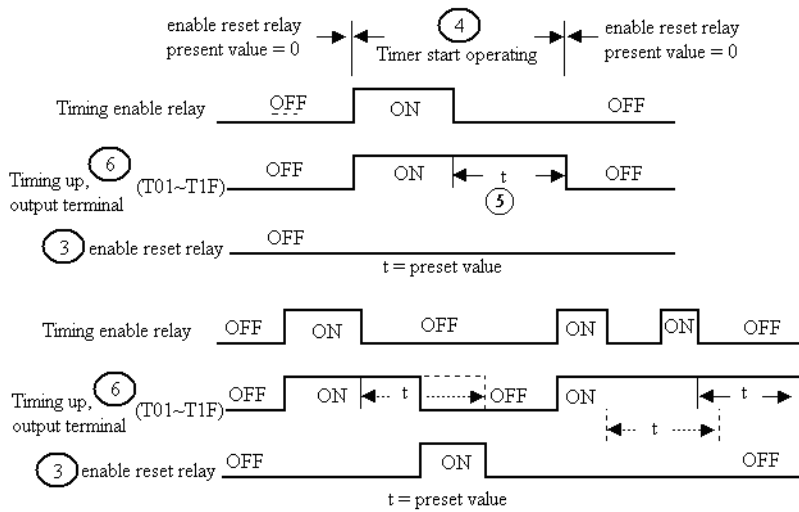

※ TOE and TOF keep their current value after a loss of power to the smart relay if “M Keep” is active, but the others’ reset to 0.

### Timer Mode 4 (OFF-Delay)

Mode 4 Timer is an OFF-Delay with reset that will time up to a fixed preset value and stop timing when the current time is equal to the preset value. Additionally, the Timer current value will reset to zero when Timer is disabled. In the example below, the timer reset input is Input I01. The timer status bit T01 will turn ON only after its rung transitions from true to false. Timer status bit T01 will turn OFF when the current time value reaches its preset value of 10 seconds.

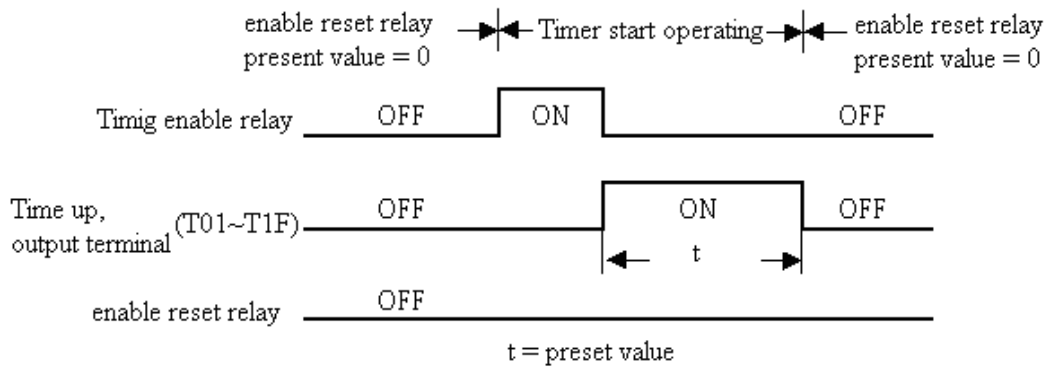

※ TOE and TOF keep their current value after a loss of power to the smart relay if “M Keep” is active, but the others’ reset to 0.

### Timer Mode 5 (FLASH without reset)

Mode 5 Timer is a Flash timer without reset that will time up to a fixed preset value and then change the state of its status bit. Additionally, the Timer current value will reset to zero when Timer is disabled. In the example below, timer status bit T01 will be ON immediately when its rung is true and begin its timing sequence. Timer status bit T01 will turn OFF when the current time value reaches its preset of 10 seconds. This Flash sequence of the Timer status bit T01 will continue as long as its rung remains true.

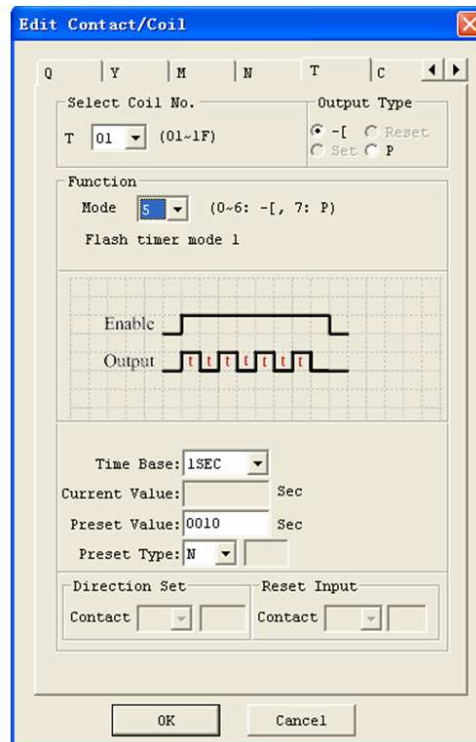
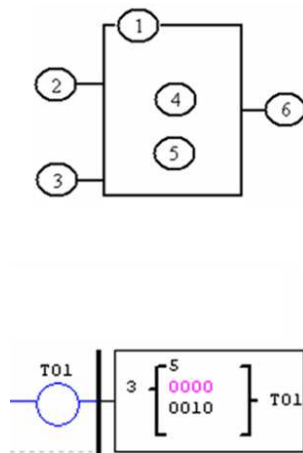



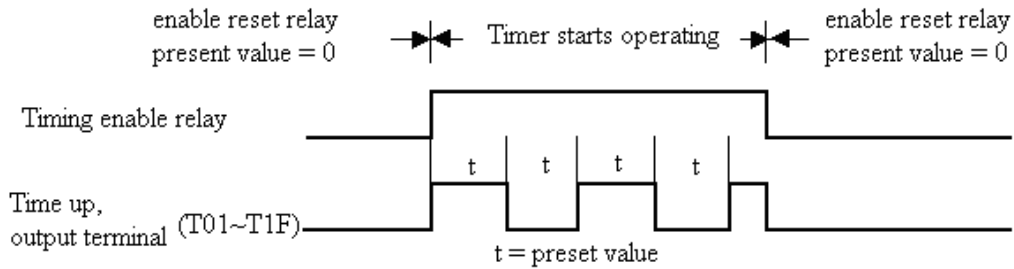

✘ The current value of Timer can not be kept on a loss of power to smart.

### Timer Mode 6 (FLASH with Reset)

Mode 6 Timer is a Flash timer with reset that will time up to a fixed preset value and then change the state of its status bit. Additionally, the Timer will reset when disabled. In the example below, the timer reset input is Input I01. Timer status bit T01 will be ON immediately when its rung is enabled and begin its timing sequence. Timer status bit T01 will turn OFF when the current time value reaches its preset of 10 seconds. This Flash sequence of the timer status bit T01 will continue as long as it is enabled.

1

2

3

4

5

6

T01

I01

3

6

0000

0010

T01

Edit Contact/Coil

Q Y M N I c

Timer: T 01 (01-1F)

Output Type:  -[  Reset  Set  P

Function: Mode 6 (0-6: -, 7: P)

Flash timer mode 2

Enable

Reset

Output

Time Base: 1SEC

Current Value: SEC

Preset Value: 0010 SEC

Preset Type: N

Direction Set: Contact

Reset Input: Contact I 01

OK Cancel

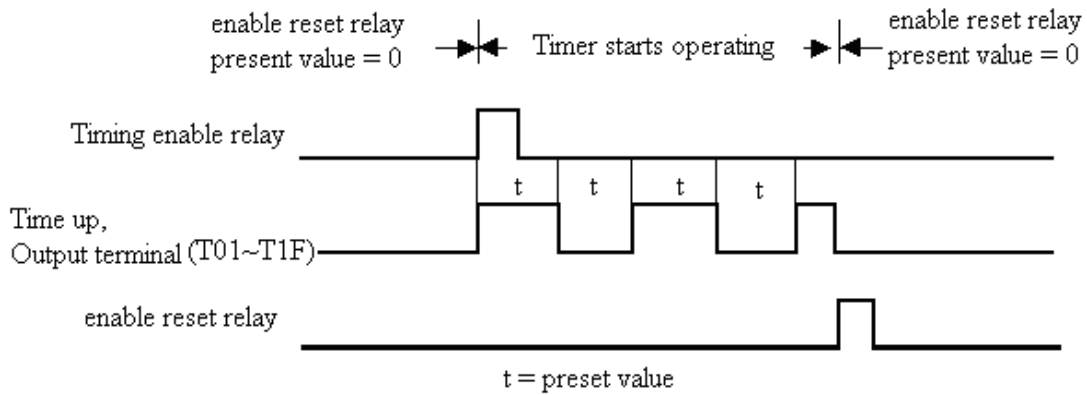

✘ The current value of Timer cannot be kept on a loss of power to smart.

### Timer Mode 7 (Asynchronous, or flash timer - without Reset)

Mode 7 creates an asynchronous timer using two standard timers, activating the second(on) timer after the first(off) time has finished. Additionally, the Timer current value resets when disabled. In the example below, timer status T01 will be ON after it completes its timing sequence of 2.5 seconds. Timer 2 will then begin its timing sequence of 1 second. When the current time value of Timer 2 reaches its preset of 1 second, its status bit T02 will flash for one program scan and Timer 1 will begin timing again. ✘ The two Timers used in Timer Mode 7 cannot be reused as Timers for other modes within the same program.

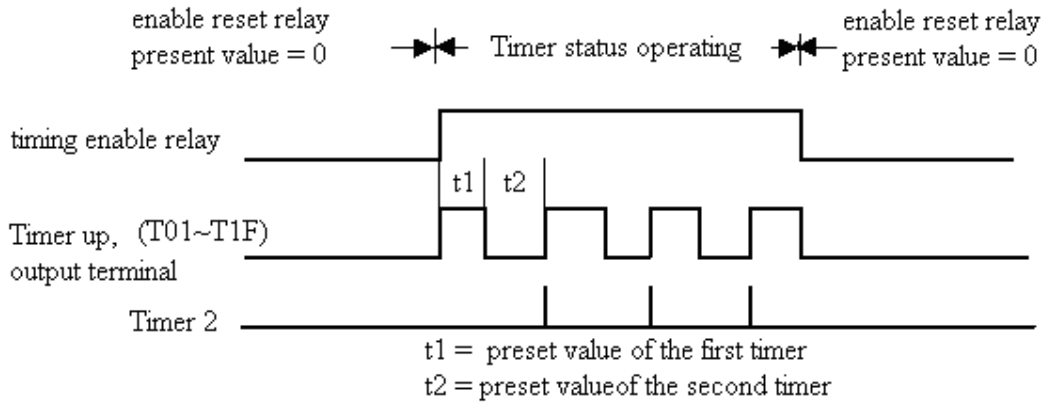

※ The current value of Timer is lost after power-down of iSmart.

### Counter Instructions

The SMT includes a total 31 separate counters that can be used throughout a program. Each counter has a choice of 9 operation modes, 1 pulse counter, 6 for general purpose counting and 2 for high speed counting. Additionally, each counter has 6 parameters for proper configuration. The tables below describe each configuration parameter lists each compatible memory type for configuring counters.

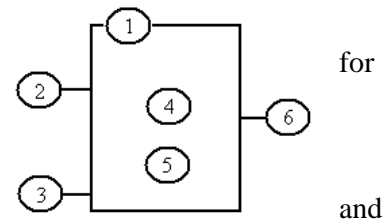

### Common Counter

Symbol	description
①	Counting Mode (0-6)
②	Use (I01~g1F) to set counting up or down OFF: counting up (0, 1, 2, 3.....) ON: counting down (.....3, 2, 1, 0)
③	Use (I01~g1F) to reset the counting value ON: the counter value reset to 0 OFF: the counter continues to count
④	Counter current Value, range: 0~999999
⑤	Counter preset Value, range: 0~999999
⑥	Counter Code (C01~C1F total: 31 Counters)

Compatible Instructions	Range
Input	I01-I0C/i01-i0C
Keypad input	Z01-Z04/z01-z04
Output	Q01-Q08/q01-q08
Auxiliary coil	M01-M3F/m01-m3F
Auxiliary coil	N01-N3F/n01-n3F
Expansion input	X01-X0C/x01-x0C
Expansion output	Y01-Y0C/y01-y0C
RTC	R01-R1F/r01-r1F
Counter	C01-C1F/c01-c1F
Timer	T01-T1F/t01-t1F
Analogue comparator	G01-F1F/g01-g1F
Normal close contact	Lo

※ The preset value of Counter could be a constant or other function current value.

The figure below shows the relationship among the numbered block diagram for a Counter, the ladder diagram view, and the software Edit Contact/Coil dialog box.

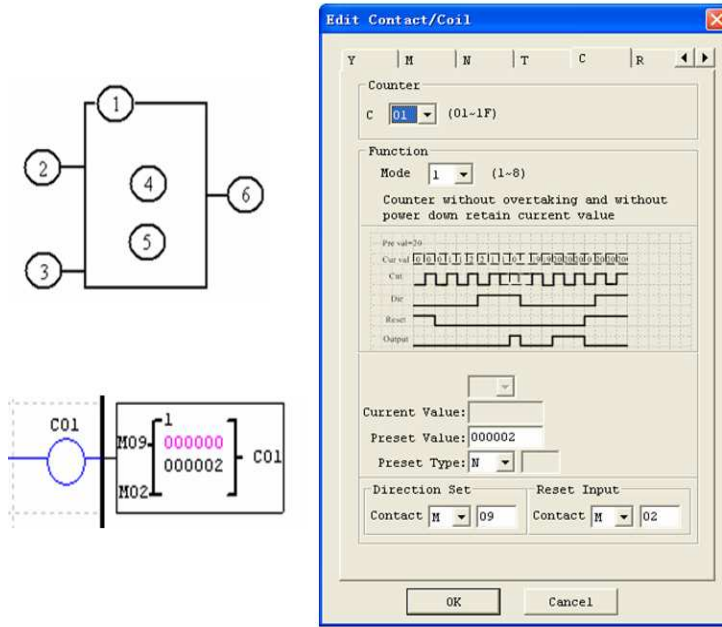

### Counter Mode 0 (Internal coil)

Mode 0 Counter (Internal Coil) used as internal auxiliary coils. No counter preset value. In the example below shows the relationship among the numbered block diagram for a mode 0 counter, the ladder diagram view, and the software Edit Contact/Coil dialog box.

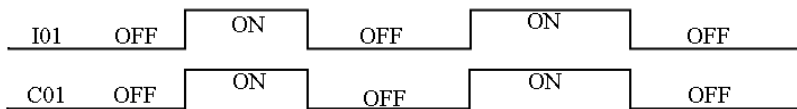
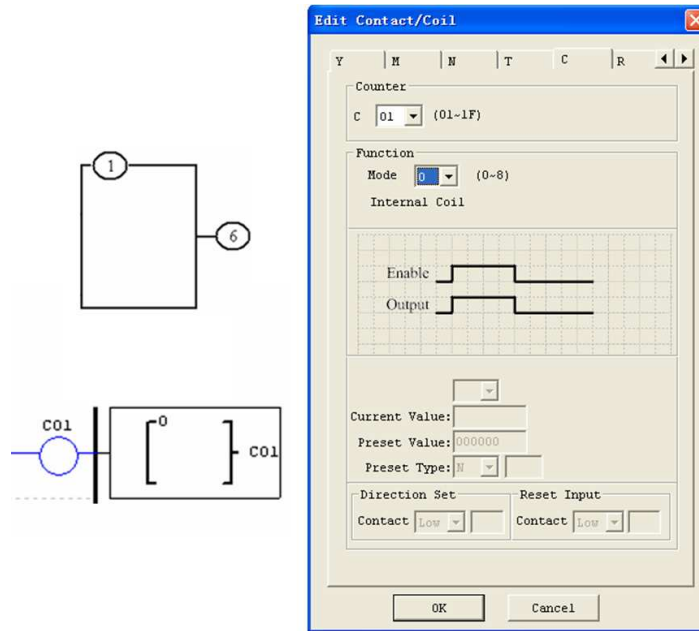

## Counter Mode 1 (Fixed Count, Non-Retentive)

Mode 1 Counter will count up to a fixed preset value and stop counting when the current count is equal to the preset value, or count down to 0 and stop counting when the current count is equal to 0. Additionally, the current count value is non-retentive and will reset to init value on a powering up to the smart relay. In the example below, the counter will stop counting when it reaches the preset value of 20. Counter status bit C01 will be ON when the current value is 20.

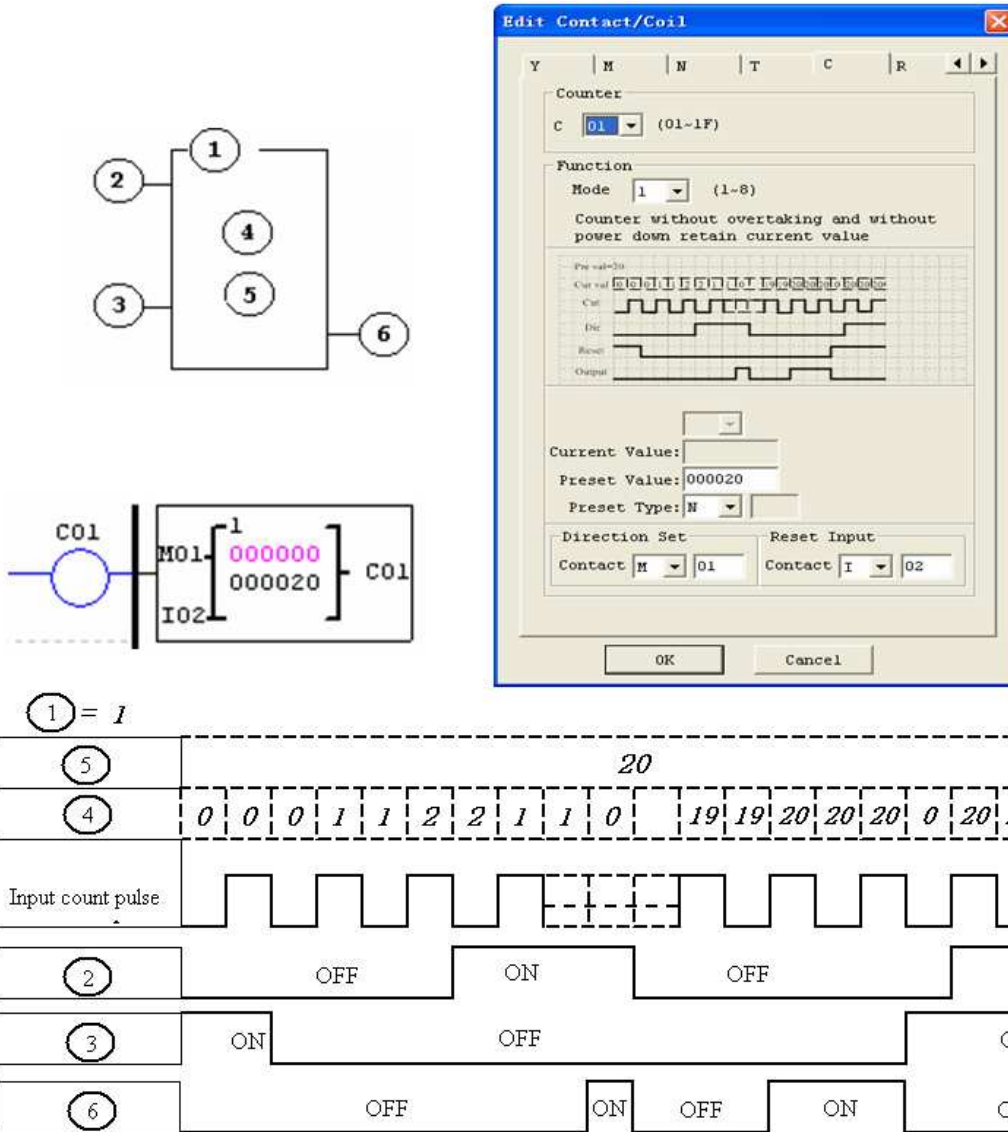

✘ Under this mode, the counter current value will be init value when the smart is power up or switching between RUN and STOP. The init value is 0 if the counter configured as counting up, else, it is preset value.

## Counter Mode 2 (Continuous Count, Non-Retentive)

Mode 2 Counter will count up to a fixed preset value and continue counting after the preset value, but it won't count when the current value equals 0 if it's configured as down Counter. Additionally, the current count value is non-retentive and will reset to init value on a powering up to the smart relay or switching between RUN and STOP. In the example below, the counter will continue counting after its preset value of 20. Counter status bit C01 will be ON when the current value is 20.

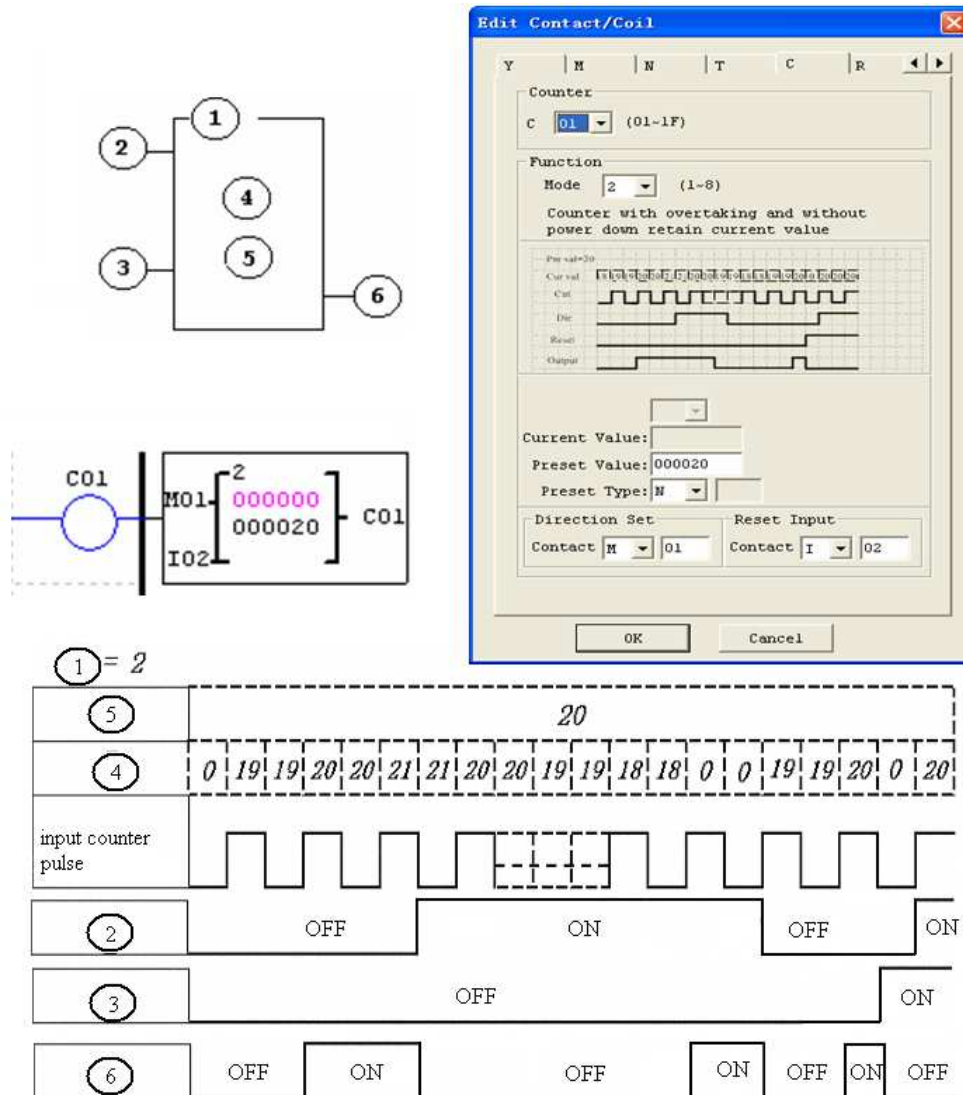

- ✘ Under this mode, Counter will continue counting after reaching preset value if it's configured as counter up. But it stops counting when its current value is 0 if it's configured as counter down.
- ✘ The counter current value will be init value when the smart's status switches between RUN and STOP or the smart is power up. If the counter configured as counting up, the init value is 0, else, it is preset value.

### Counter Mode 3 (Fixed Count, Retentive)

Mode 3 Counter operation is similar to Mode 1 except its current count value is retentive when Counter powers down. So, the current value won't be init value when Counter powers up, but be the value when it powering down. Mode 3 Counter will count up to a fixed preset value and stop counting at that value, or stop counting when its current value is 0 if it's configured as down counter. Additionally, the current count value is retentive when the smart switches between RUN and STOP if "C Keep" is active. In the example below, the counter will stop counting when it reaches the preset value of 20. Counter status bit C01 will be ON when the current value is 20.

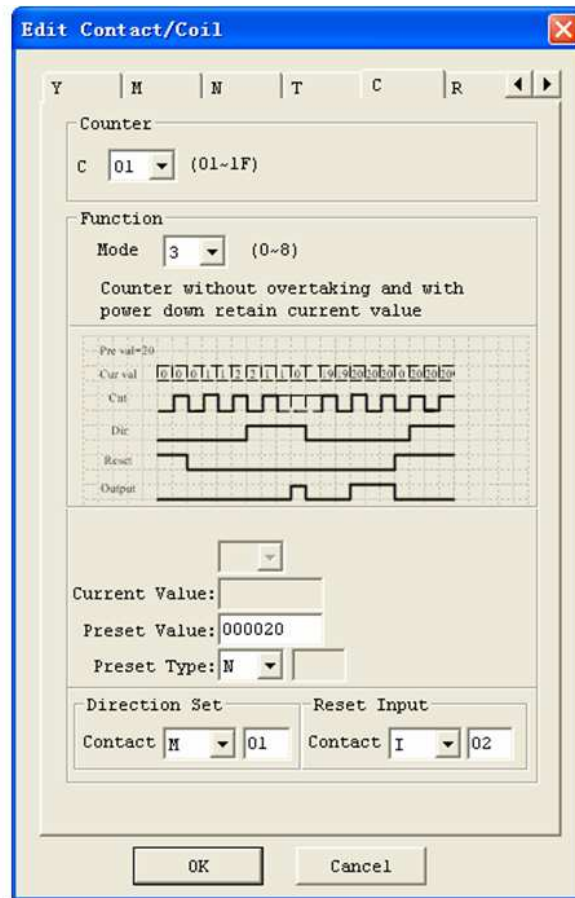
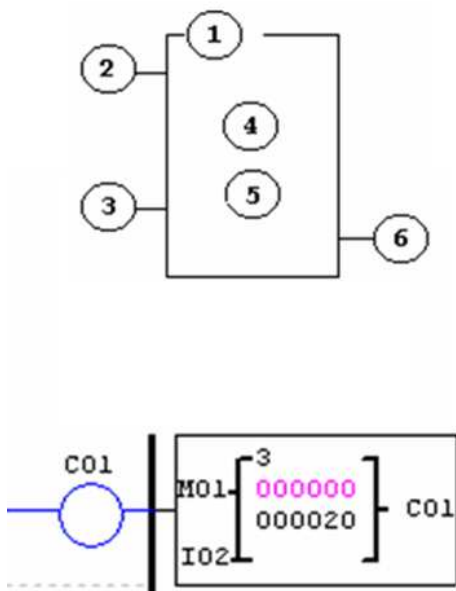

This mode is similar to mode 1, but:

- ✘ The current counter value will keep on a loss of power when the smart status is RUN;
- ✘ The current counter value will keep when the smart switches between RUN and STOP if C-keep is active.

## Counter Mode 4 (Continuous Count, Retentive)

Mode 4 Counter operation is similar to Mode 2 except its current count value is retentive. The current count value is retentive and will keep its current count after a loss of power to the smart relay. Mode 4 Counter will count up to a fixed preset value and then continue counting after the preset value, but it won't count when the current value equals 0 if it's configured as down Counter. Additionally, the current count value is retentive when the smart switches between RUN and STOP if "C Keep" is active. In the example below, the counter will continue counting after its preset value of 20. Counter status bit C01 will be ON when the current value isn't less than 20.

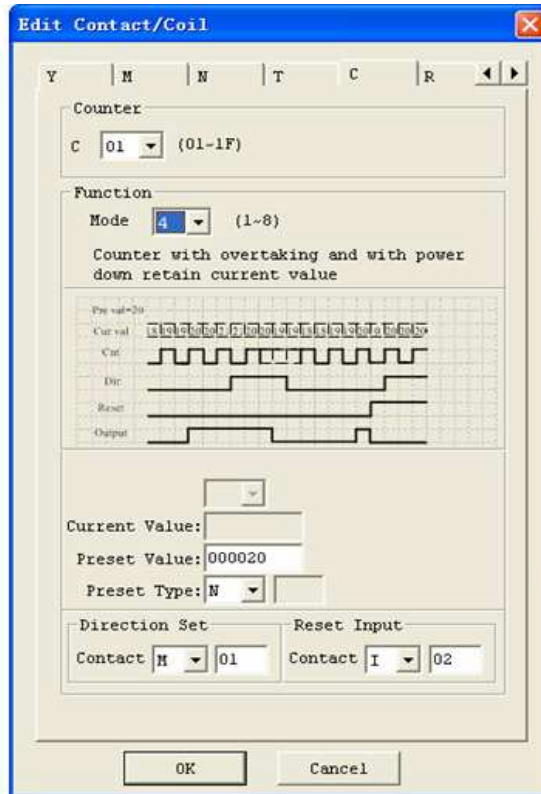
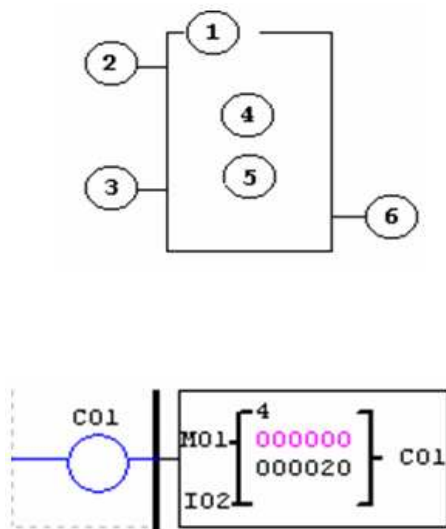

This mode is similar to mode 2, but:

- ✘ The current counter value will be kept on a loss of power when the smart status is RUN;
- ✘ The current counter value will be kept when the smart switches between RUN and STOP if "C-keep" is active.



## Counter Mode 5 (Continuous Count, Up-Down Count, Non-Retentive)

Mode 5 Counter's operation is similar to Mode 2 except its current count value is continuous and non-retentive. The status bit is fixed to the non-zero preset value regardless of the state of the direction bit. Its status bit will be ON when the counter current value isn't less than its preset value, and will be OFF when the current value is less than its preset value.

The Mode 5 Counter will count up to a fixed preset value and continue counting after the preset value.

Additionally, the current count value is non-retentive and will reset to 0 on a loss of power to the smart relay.

Additionally, the Mode 5 counter is always reset to zero, and the current value also is always 0 when the smart switches between RUN and STOP unrelated to the state of its direction bit. In the example below, the counter will continue counting after its preset value of 20. Counter status bit C01 will be ON when the current value is 20.

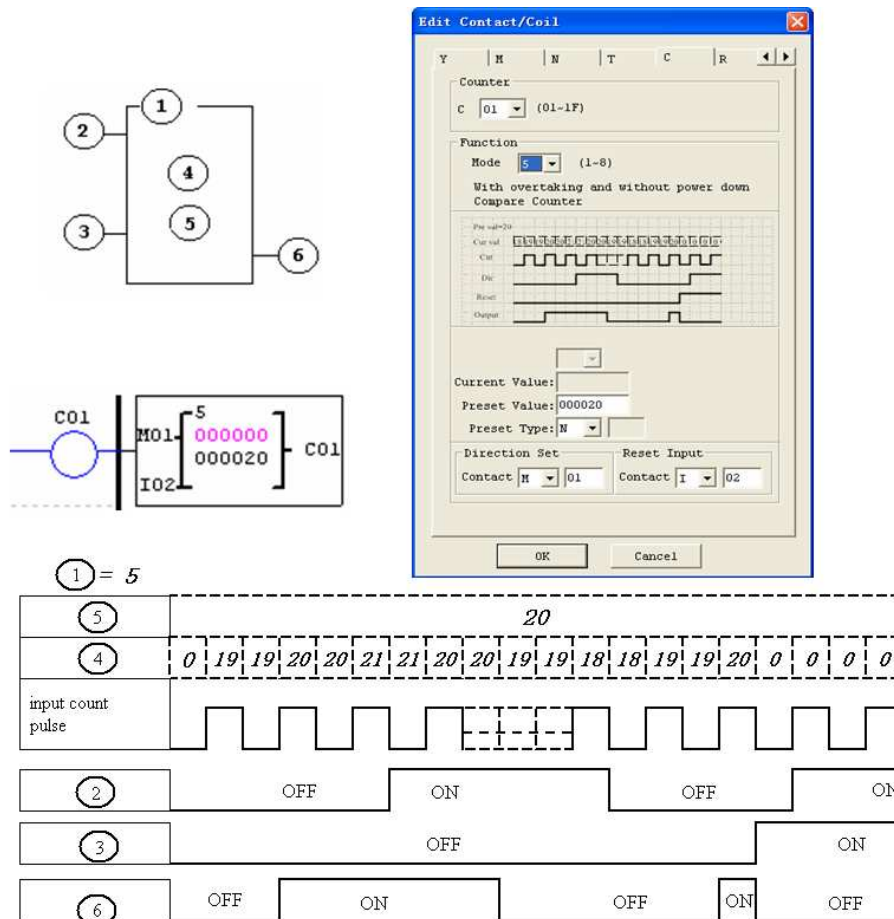

- ✘ Under this mode, the count will continuous after reaching its preset value;
- ✘ The current value is always 0 regardless of the state of its direction bit when the reset is availability;
- ✘ The current value is always 0 regardless of the state of its direction bit when the smart switches between RUN and STOP.

## Counter Mode 6 (Continuous Count, Up-Down Count, Retentive)

Mode 6 Counter's operation is similar to Mode 4 except its current count value is continuous and retentive. The status bit is fixed to the non-zero preset value regardless of the state of the direction bit. Its status bit will be ON when the counter current value isn't less than its preset value, and will be OFF when the current value is less than its preset value. Additionally, the Mode 6 counter is always reset to zero, unrelated to the state of its direction bit. The current count value is retentive and will keep its current count after a loss of power to the smart relay. And Counter will keep current value if "C Keep" is active. In the example below, the counter will continue counting after its preset value of 20. Counter status bit C01 will be ON when the current value isn't less than 20.

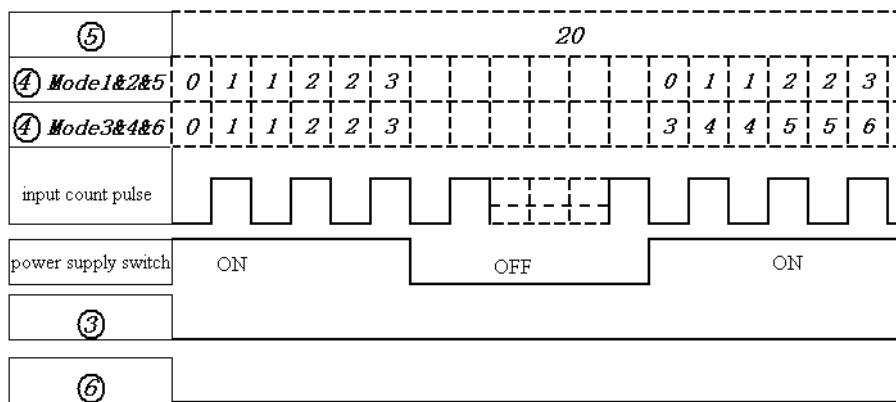
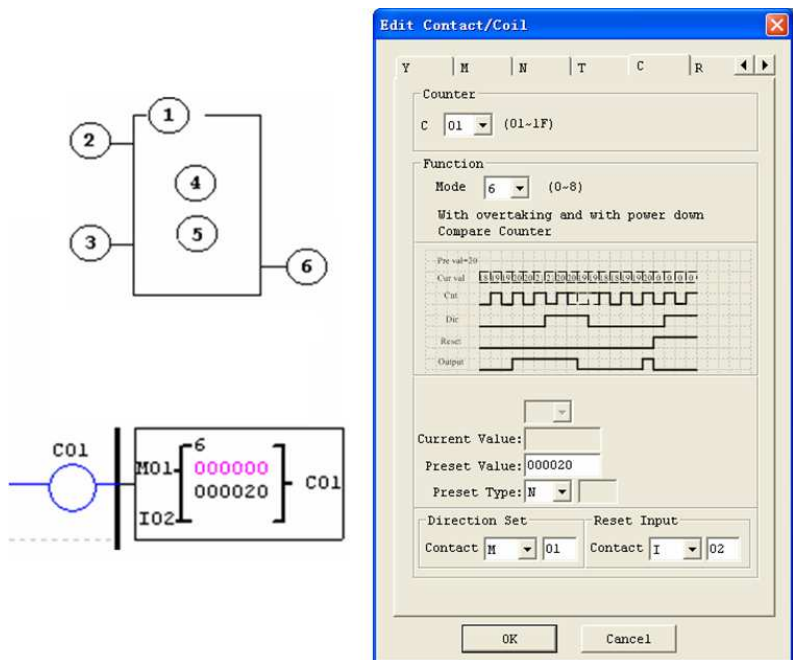

This mode is similar to mode 5, but:

- ✘ The current value is kept on a loss of power down to the smart when it status is RUN;
- ✘ The current value is kept when the smart switches between RUN and STOP if "C Keep" is active.

## High Speed Counters (DC Version Only)

The DC powered version smart relays include two 1 KHz high speed inputs on terminal I01 and I02. These can be used as general purpose DC inputs or can be wired to a high speed input device (encoder, etc.) when configured for high speed counting. They are often used for counting something moving very fast (>40Hz) or used as a speed reference on a machine. The high speed counters are configured using the same software Edit Contact/Coil dialog box, except selecting Counter Mode 7 or Mode 8.

### High Speed Counter Mode 7 (DC powered versions only)

The Mode 7 High Speed Counter can use either input terminals I01 or I02 for forward up-counting to 1 KHz maximum at 24VDC high speed input signal. The selected Counter Coil (C01-C1F) will turn ON when the pulse count reaches preset value and remain ON. The counter will reset when the preceding rung is inactive or the Reset Input is active. In the example below shows the relationship among the numbered block diagram for a Mode 7 Counter, the ladder diagram view, and the software Edit Contact/Coil dialog box.

Symbol	Description
①	Counting Mode (7) high speed counting
②	High speed counting input terminal: I01 or I02 only
③	Use (I01~g1F) to Reset the counting value ON: the counter reset to 0 OFF: the counter continues to count
④	Current Count Value, range: 0~999999
⑤	Preset Value, range: 0~999999
⑥	Counter Coil Number (C01~C1F total: 31 counters)

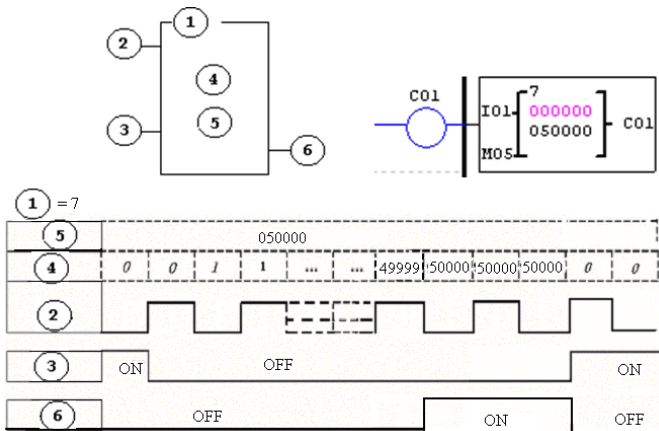

Example:

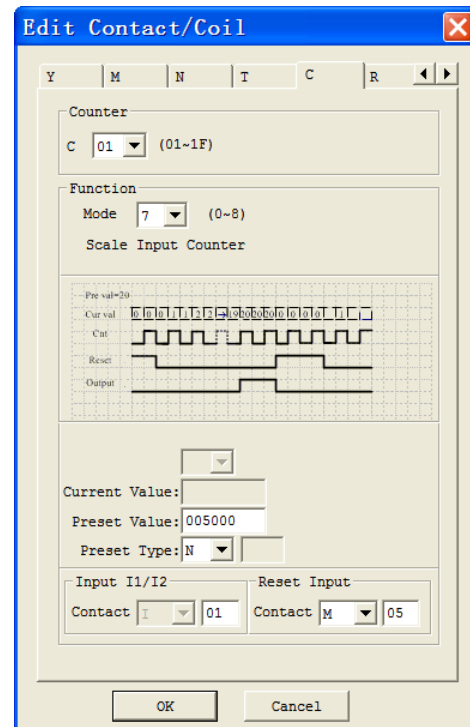
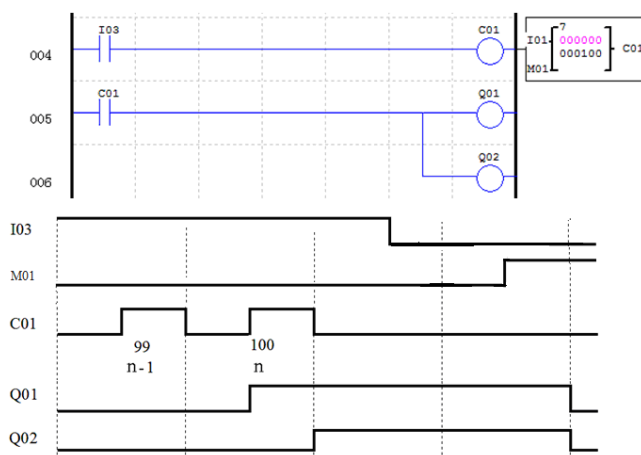

### High Speed Counter Mode 8 (DC powered versions only)

The Mode 8 High Speed Counter can use either input terminals I01 or I02 for forward up-counting to 1 KHz maximum at 24VDC high speed input signal. The selected Counter Coil (C01-C1F) will turn ON when the pulse count reaches the target “Preset ON” value and remain ON until the pulse count reaches the target “Preset OFF” value

Symbol	Description
①	Counting Mode (8) high speed counting
②	High speed counting input terminal: I01 or I02 only
③	Counting interval time: 0~99.99 sec
④	Counter ‘on’ preset Value, range: 0~999999
⑤	Counter ‘off’ preset Value, range: 0~999999
⑥	Counter Coil Number (C01~C1F total: 31 counters)

value. The counter will reset when the preceding rung is inactive. The table below describes each configuration parameter for High Speed Counter Mode 8.

The diagram shows a counter coil configuration with terminals 1 through 6. Terminal 1 is the coil output, 2 and 3 are input terminals, 4 and 5 are preset value inputs, and 6 is the coil number. Below it is a ladder logic rung showing a coil C01 with a counter block. The counter block has inputs for Mode (8), OFF value (000003), and ON value (000005). The software window 'Edit Contact/Coil' shows the configuration for Counter C01, Mode 8, and various preset values and types.

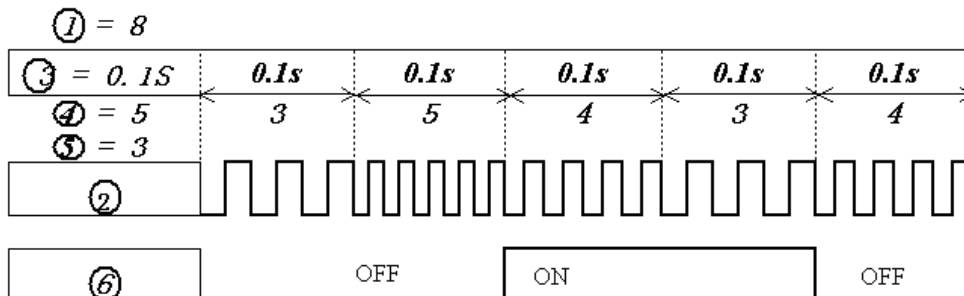

**Real Time Clock (RTC) Instructions**

The ISmart relay includes a total of 31 separate RTC instructions that can be used throughout a program. Each RTC instruction has a choice of 5 operation modes, and has 10 parameters for proper configuration. The initial clock/calendar setting for each connected SMT is set using the **Operation>RTC Set** menu selection from the SMT Client software.

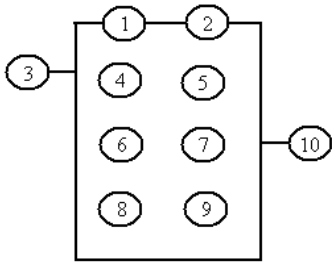
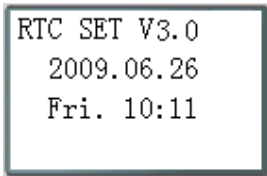

Symbol	Description
①	Input the first week to RTC
②	Input the second week to RTC
③	RTC mode 0~2, 0: internal coil 1:daily, 2:consecutive days
④	RTC displays the hour of present time.
⑤	RTC displays the minute of present time
⑥	Set RTC hour ON
⑦	Set RTC Minute ON
⑧	Set RTC Hour OFF
⑨	Set RTC Minute OFF
⑩	RTC Coil Number (R01~R1F Total: 31 RTC)

**RTC Mode 0 (Internal Coil)**

Mode 0 RTC (Internal Coil) used as internal auxiliary coils. No preset value. In the example below shows the relationship among the numbered block diagram for a Mode 0 RTC, the ladder diagram view, and the software Edit Contact/Coil dialog box.

The block diagram shows a vertical rectangle with inputs 3 and 10. The ladder logic diagram shows a normally open contact labeled I01 in series with a coil labeled R01. Below the ladder logic is a timing diagram showing I01 and R01 both transitioning from OFF to ON at the same time. The 'Edit Contact/Coil' dialog box shows 'Real time clock' settings: R 01 (01-1F), Function Mode 0 (0-4), Internal Coil, a week table, and a timing diagram for Enable and Rx.

## RTC Mode 1 (Daily)

The Daily Mode 1 allows the Rxx coil to active based on a fixed time across a defined set of days per week. The configuration dialog below (example 1) allows for selection of the number of days per week (i.e. Mon-Fri) and the Day and Time for the Rxx coil to activate ON, and the Day and Time for the Rxx coil to deactivate OFF.

Example 1:

The diagram shows a 10-pin terminal block with pins 1-10. Pin 10 is connected to a coil labeled R01. The configuration dialog 'Edit Contact/Coil' shows the following settings:

- Real time clock: R 01 (01-1F)
- Function: Mode 1 (0-4), Every day action mode
- Week (On->Off): MO -> FR
- Current Value: 10:05
- Preset Value: 08 : 00 On 17 : 00 Off (hour:minute)

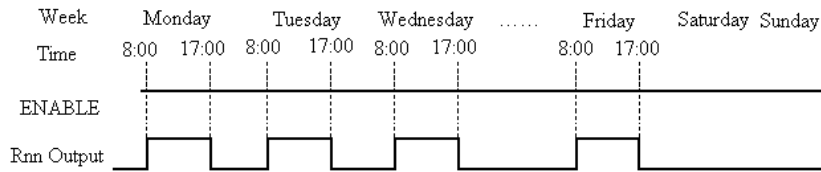

Example 2:

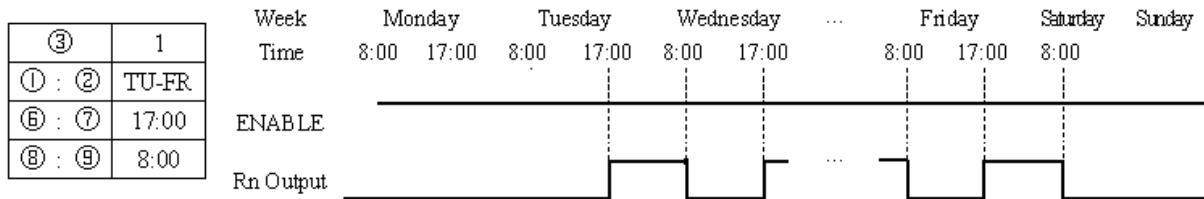

Example 3:

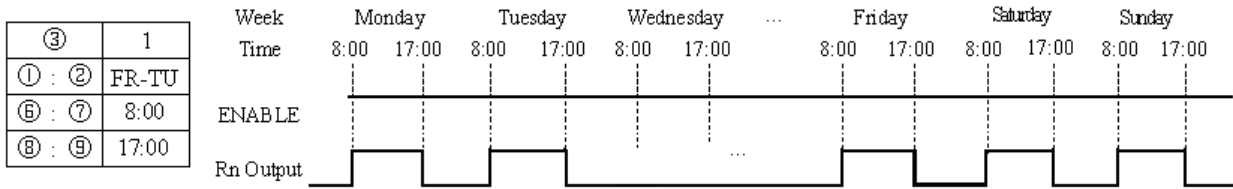

Example 4:

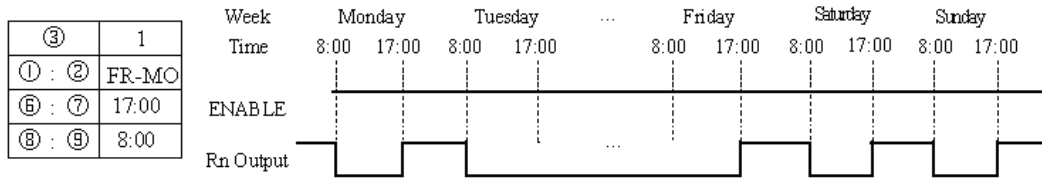

Example 5:

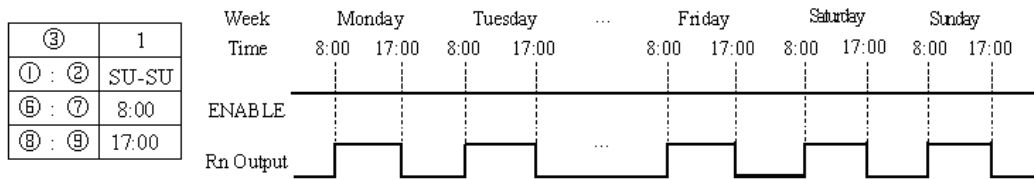

Example 6:

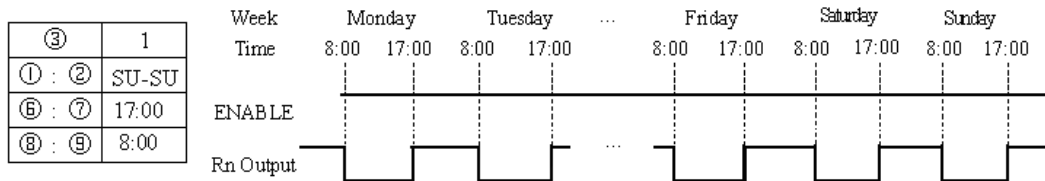

### RTC Mode 2 (Interval weekly)

The Interval Time Mode 2 allows the Rxx coil to activate based on time and day per week. The configuration dialog below (example 1) allows for selection of Day and Time for the Rxx coil to activate ON, and Day and Time for the Rxx coil to deactivate OFF.

Example 1:

The diagram shows a 3-phase motor with terminals 1, 2, 3, 4, 5, 6, 7, 8, 9, and 10. Terminal 3 is connected to terminal 4, and terminal 10 is connected to terminal 9. The configuration dialog 'Edit Contact/Coil' shows the following settings:

- Real time clock: R 01 (01-1F)
- Function: Mode 2 (0-4)
- Interval time action mode: Enable (graph showing a pulse), Rt (graph showing a step function)
- Week (On->Off): TU -> SA
- Current Value: 10:22
- Preset Value: 08 : 00 On 17 : 00 Off (hour:minute)

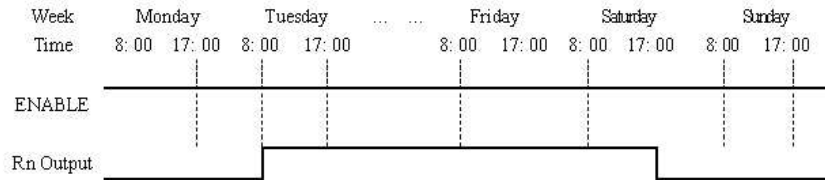

Example 2:

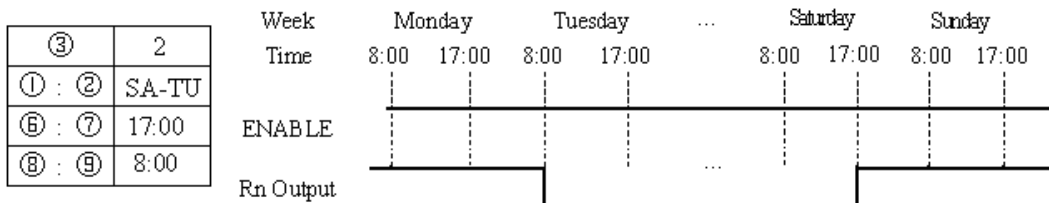

Example 3:

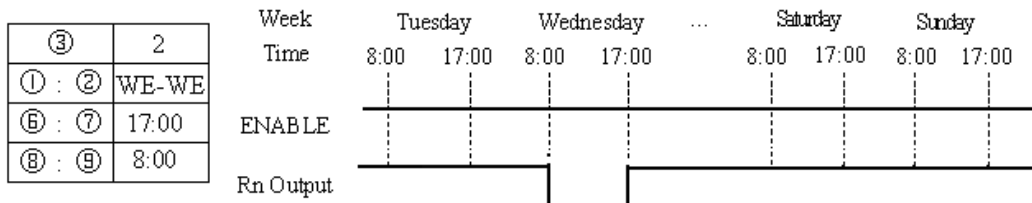

Example 4:



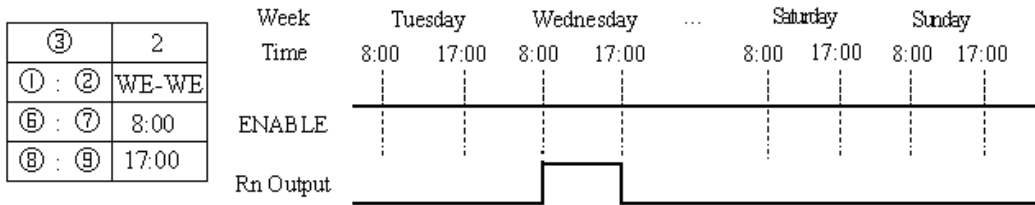

### RTC Mode 3 (Year-Month-Day)

The Year-Month-Day Mode 3 allows the Rxx coil to activate based on Year, Month, and Date. The configuration dialog below (example 1) allows for selection of Year and Date for the Rxx coil to activate ON, and Year and Date for the Rxx coil to deactivate OFF.

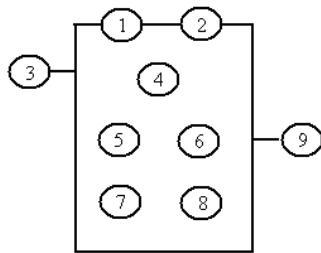

Symbol	Description
①	RTC Year ON
②	RTC Year OFF
③	RTC Mode 3, Year-Month-Day
④	Display RTC present time, Year-Month-Day
⑤	RTC month ON
⑥	RTC day ON
⑦	RTC month OFF
⑧	RTC day OFF
⑨	RTC code (R01~R1F, total 31 group)

Example 1:

Example 2:

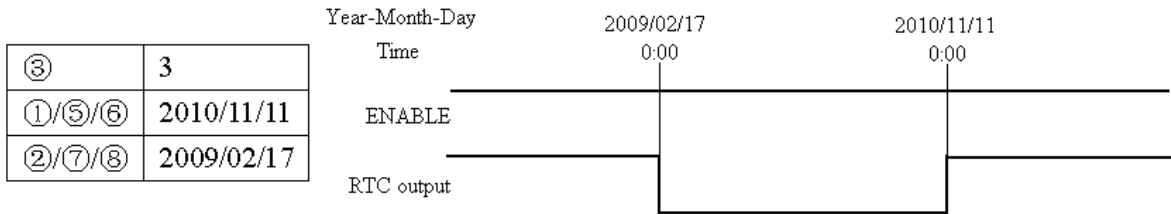

Example 3:

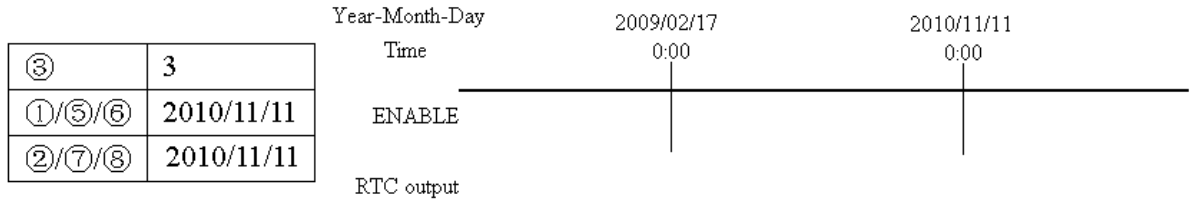

### RTC Mode 4 (30-second adjustment)

The 30-second adjustment Mode 4 allows the Rxx coil to activate based on week, hour, minute and second. The configuration dialog below shows for selection of week, hour, minute and second for the Rxx coil to activate ON, and 30-second adjustment then Rxx OFF.

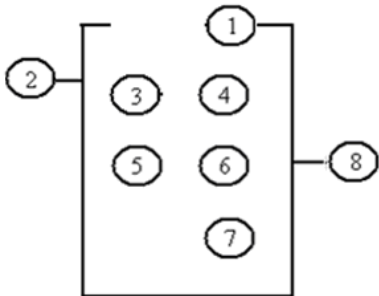

Symbol	Description
①	RTC adjustment week
②	RTC mode 4
③	RTC present hour
④	RTC present minute
⑤	RTC adjustment hour
⑥	RTC adjustment minute
⑦	RTC adjustment second
⑧	RTC code (R01~R1F, total 31 group)

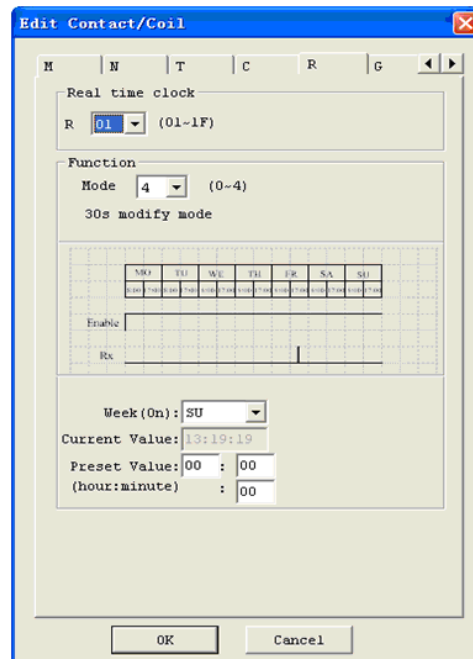

Example 1: preset second < 30s

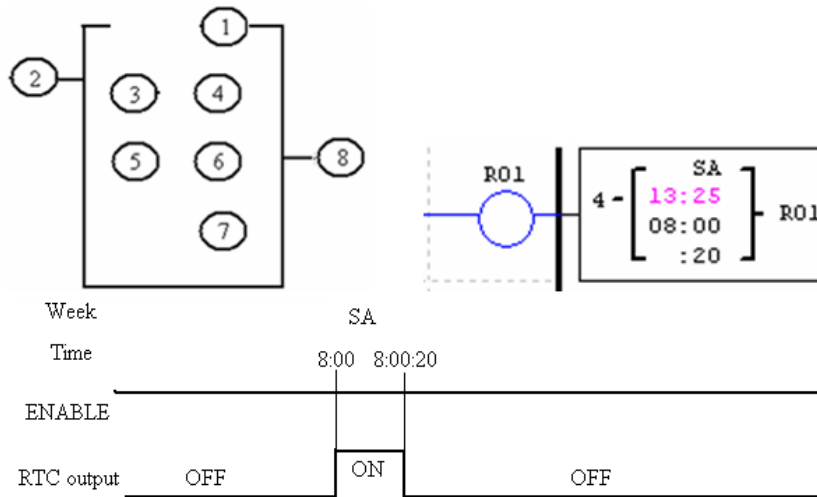

✘ The present time will be 8:00:00 when it achieves 8:00:20 at first time, and RTC status bit R01 will be ON. RTC status bit R01 will be OFF when the present time achieves 8:00:20 at second time. Then time continuous going. So, this means that RTC status bit is ON for 21 seconds.

Example 2: preset second > 30s

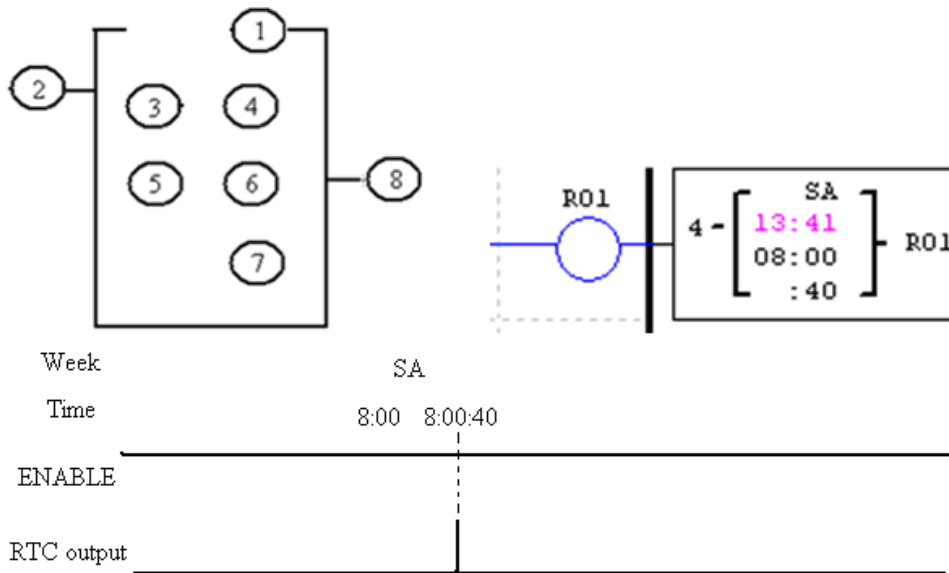

✘ The present time will change to be 8:01:00 when it achieves 8:00:40, and RTC status bit R01 turns ON. Then time is gonging on and R01 turns OFF. This means that the RTC status bit will be ON for one pulse.

### Comparator Instructions

The ISmart relay includes a total of 31 separate comparator instructions that can be used throughout a program. Each comparator has a choice of 8 operation modes. Additionally, each comparator has 5 parameters for proper configuration. The table below describes each configuration parameter, and lists each compatible memory type for configuring Comparators.

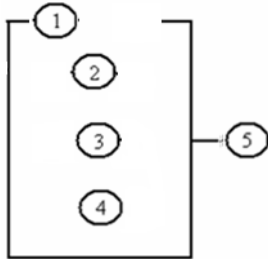

Symbol	Description
①	Comparison Mode (0~7)
②	Ax analogue input value (0.00~99.99)
③	Ay analogue input value (0.00~99.99)
④	Reference comparative value, could be constant, or other data code
⑤	Output terminal (G01~G1F)

※ The preset value ②, ③ and ④ can be a constant or other function current value.

### Comparator Mode 0 (Internal Coil)

Mode 0 Comparator (Internal Coil) used as internal auxiliary coils. No preset value. In the example below shows the relationship among the numbered block diagram for a Mode 0 Comparator, the ladder diagram view, and the software Edit Contact/Coil dialog box.

## Analogue comparator Mode 1~7

- (1) Analogue Comparator mode 1:  $A_y - \textcircled{4} \leq A_x \leq A_y + \textcircled{4}$ ,  $\textcircled{5}ON$  ;
- (2) Analogue Comparator mode 2:  $A_x \leq A_y$ ,  $\textcircled{5}ON$  ;
- (3) Analogue Comparator mode 3:  $A_x \geq A_y$ ,  $\textcircled{5}ON$  ;
- (4) Analogue Comparator mode 4:  $\textcircled{4} \geq A_x$ ,  $\textcircled{5}ON$  ;
- (5) Analogue Comparator mode 5:  $\textcircled{4} \leq A_x$ ,  $\textcircled{5}ON$  ;
- (6) Analogue Comparator mode 6:  $\textcircled{4} = A_x$ ,  $\textcircled{5}ON$  ;
- (7) Analogue Comparator mode 7:  $\textcircled{4} \neq A_x$ ,  $\textcircled{5}ON$  ;

Example 1: Analogue Signal Compare

In the example below, Mode 4 is the selected function that compares the value of analogue input A01 to a constant value (N) of 2.50. Status coil G01 turns ON when A01 is not less than constant 2.50.

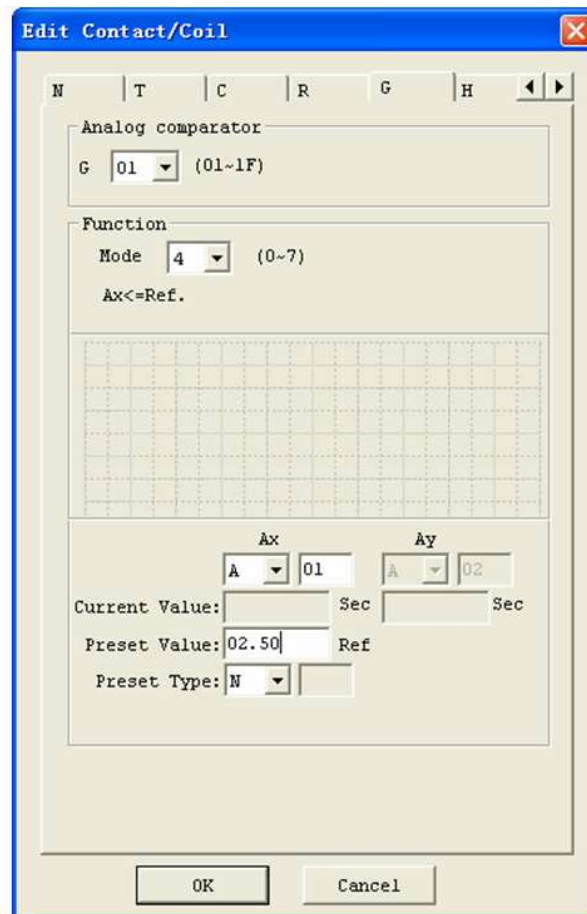
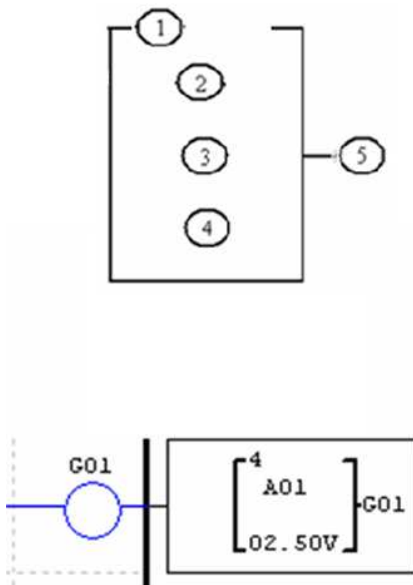

## Example 2: Timer/Counter present value Compare

The Comparator instruction can be used to compare Timer, Counter, or other function values to a constant value or each other. In this example below, Mode 5 is the selected function that compares the value of Counter (C01) with the value of Timer (T01). Status coil G01 turns ON if present value of C01 isn't less than present value of T01.

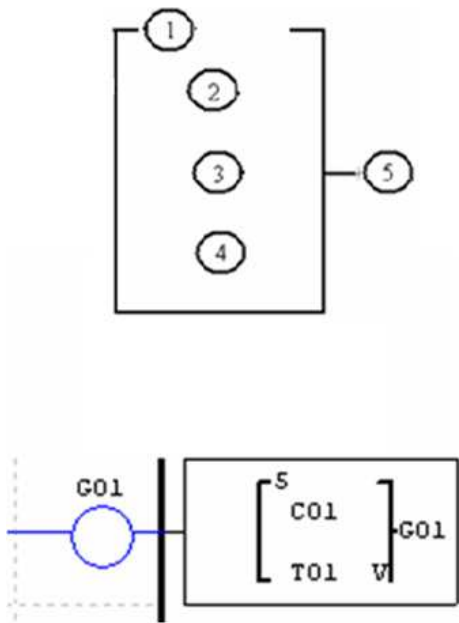

The diagram shows a ladder logic network with five nodes. Node 1 is the start of the network. Nodes 2, 3, and 4 are connected in series. Node 5 is the end of the network. A comparison instruction is shown in a box between nodes 4 and 5. The instruction is labeled 'G01' and contains the following data:

5	C01	T01	V
---	-----	-----	---

The 'G01' label is on the left and right sides of the box.

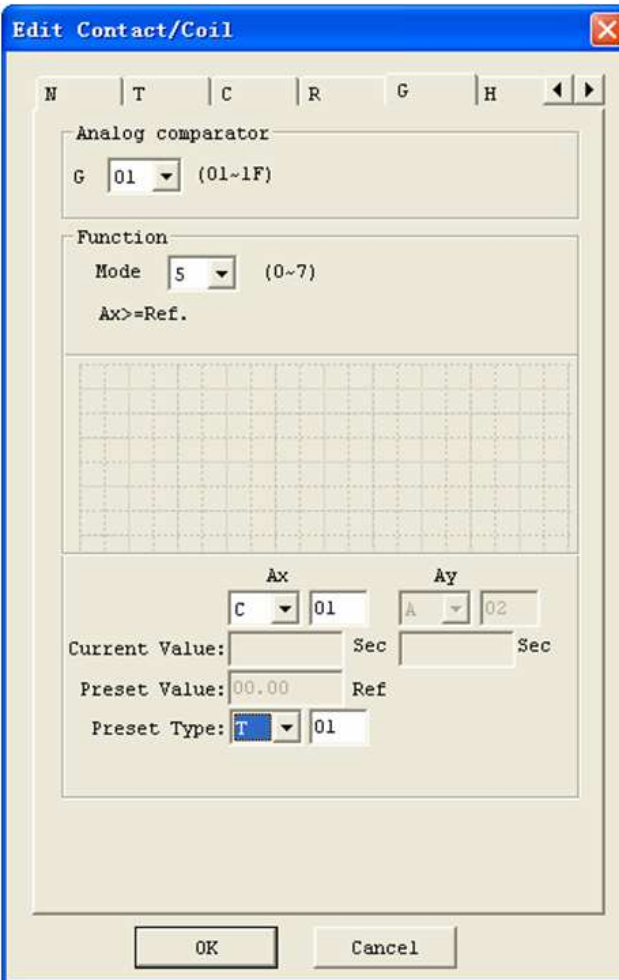

The screenshot shows the 'Edit Contact/Coil' dialog box. The dialog has a title bar with a close button. Below the title bar are tabs for 'N', 'T', 'C', 'R', 'G', and 'H'. The 'G' tab is selected. The dialog contains the following fields:

- Analog comparator: G 01 (01~1F)
- Function: Mode 5 (0~7), Ax>=Ref.
- Current Value: Ax C 01, Ay A 02, Sec
- Preset Value: 00.00, Ref
- Preset Type: T 01

At the bottom of the dialog are 'OK' and 'Cancel' buttons.

## HMI Display Instructions

The *iSmart* relay includes a total of 31 HMI instructions that can be used throughout a program. Each HMI instruction can be configured to display information on the SMT 16×4 character LCD in text, numeric, or bit format for items such as current value and preset value for functions, Input/Output bit status, and text. There are three kinds of text in HMI. They are Multi Language, Chinese (fixed) and Chinese (edit), Multi Language is shown in the adjacent example. Each HMI instruction can be configured separately using the **Edit>>HMI/Text** menu selection from the SMT Client software. In the adjacent example, HMI instruction H01 is configured to display the value of T01, and some descriptive text.

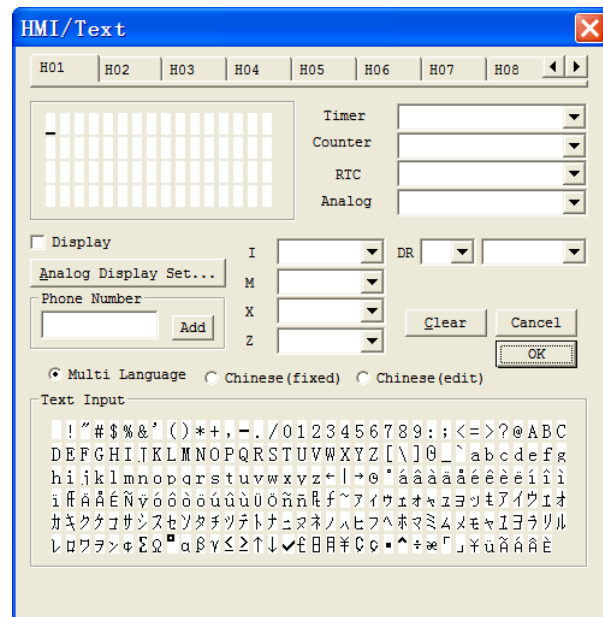

Allows the SEL button on the SMT keypad to activate the selected message onto the LCD even the Hxx is inactive.

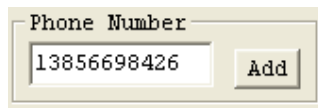

※ A phone number can be displayed on the screen to alert an operator to call for help. But the phone number field does not dial a modem or allow for a modem connection.

Each HMI instruction has a choice of 2 operation modes. The table below describes each configuration parameter.

Symbol	Description
①	Display mode (1-2)
②	HMI character output terminal (H01~H1F)

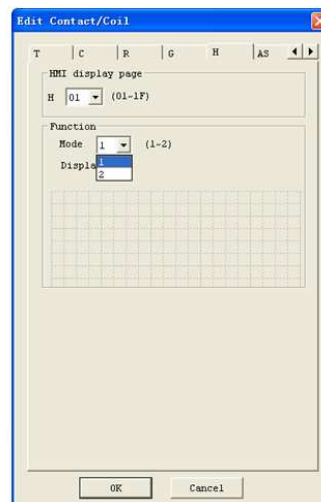
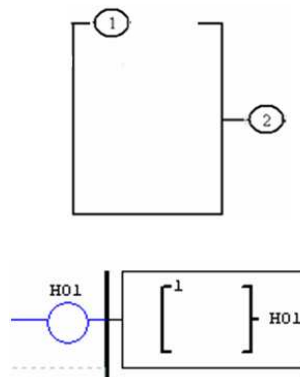

The Chinese (fixed) and Chinese (edit) are shown below. The total number of Chinese (edit) is 60.

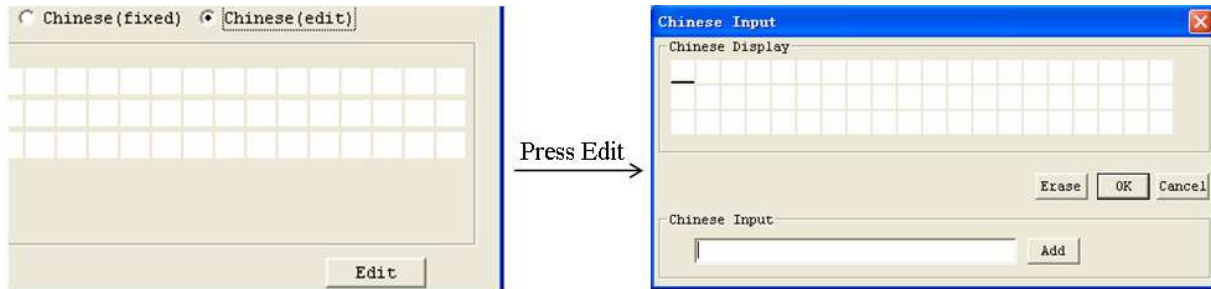
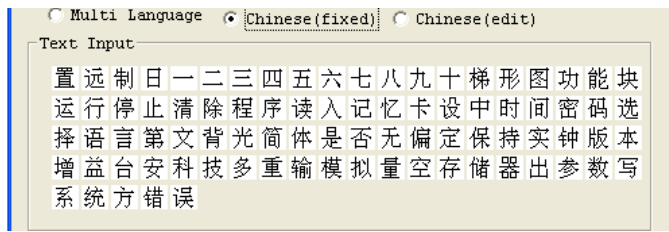

### HMI function instruction

1. HMI can display characters, built-in Chinese, user-defined Chinese and GSM telephone number. This information cannot be edited through the keypad.
2. HMI can display function current values (T, C, R, G and DR, classifying units). This information cannot be edited through the keypad.
3. HMI can display preset value of functions (T, C, R, G and DR). This information can be edited through the keypad.
4. HMI display state of coil (I, X, Z, M and N (only FBD)), state of M and N can be edited through the keypad.

### HMI status

1. HMI scanning state, press SEL into at IO interface

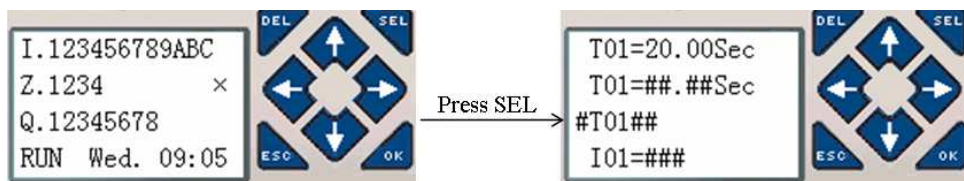

2. HMI running state, HMI is enabled at IO interface

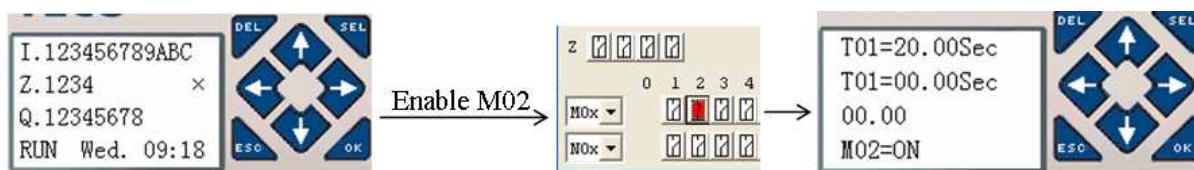

3. HMI edit preparing state, press SEL when HMI is scanning or running state, flicker cursor will



show if there is edited content.



4. HMI editing state, press SEL again under status 3



### Keypad instruction

ESC	Abrogate operation
SEL	Into status 3 if there is edited content at status 1 or 2 Into status 4 Change preset type under status 4
↑ ↓ (SEL+↑ ↓)	Under status 4, change data and number, function preset data; change coil state Not in status 4, move cursor up and down Under status 2, find the nearest enabled HMI Under status 1, find the nearest HMI whose mode is 1
← →	Move cursor left and right
OK	Validate editing and store automatic

### PWM Output Instruction (DC Transistor Output Models Only)

The transistor output model smart relay can provide a PWM (Pulse Width Modulation) output on terminal Q01 and Q02. The PWM instruction is able to output up to an 8-stage PWM waveform. It also provides a PLSY (Pulse output) output on terminal Q01, whose pulse number and frequency can be changed. The table below describes number and mode of PWM.

	Mode	Output
P01	PWM, PLSY	Q01
P02	PWM	Q02

### PWM mode

P01 and P02 both can work under this mode. Each PWM has 8 group preset stages which contents Width and Period. The 8 group preset values can be constant or other function current value. Each PWM has 10 parameters for proper configuration. The table below describes each configuration parameter, and lists each compatible memory type for configuring PWM.

Symbol	Description
①	PWM mode (1)
②	present stages as operating (0~8)
③	Select1 (I01~g1F)
④	Select2 (I01~g1F)
⑤	Select3 (I01~g1F)
⑥	Current number of pulse (0~32767)
⑦	Period of preset stage ② (1~32767 ms)
⑧	Width of preset stage ② (0~32767 ms)
⑨	Output port (Q01~Q02)
⑩	PWM code (P01~P02)

Enable	Select3	Select2	Select1	stage	PWM Output
OFF	X	X	X	0	OFF
ON	OFF	OFF	OFF	1	Preset stage 1
ON	OFF	OFF	ON	2	Preset stage 2
ON	OFF	ON	OFF	3	Preset stage 3
ON	OFF	ON	ON	4	Preset stage 4
ON	ON	OFF	OFF	5	Preset stage 5
ON	ON	OFF	ON	6	Preset stage 6
ON	ON	ON	OFF	7	Preset stage 7
ON	ON	ON	ON	8	Preset stage 8

Example:

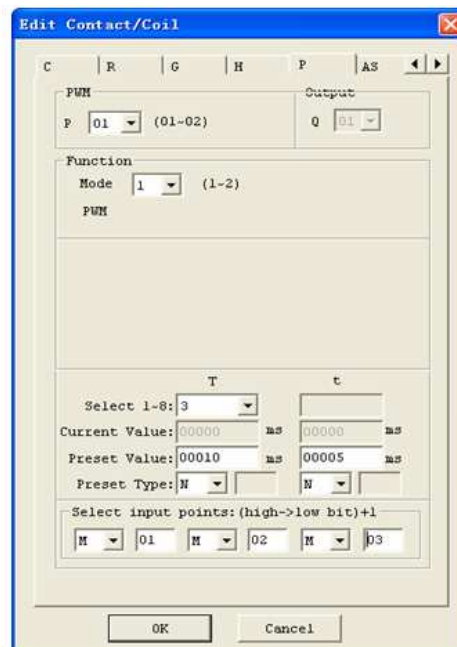
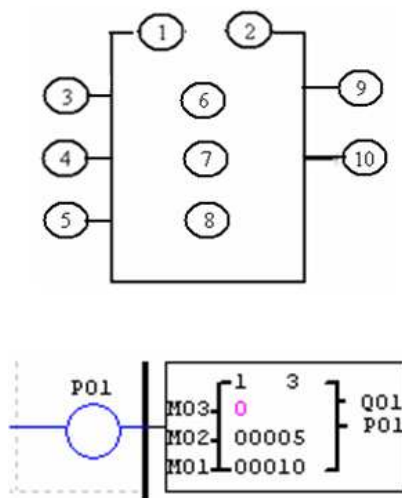

The state of M01, M02 and M03 are 010, so PWM output pulse is like this as setting above:

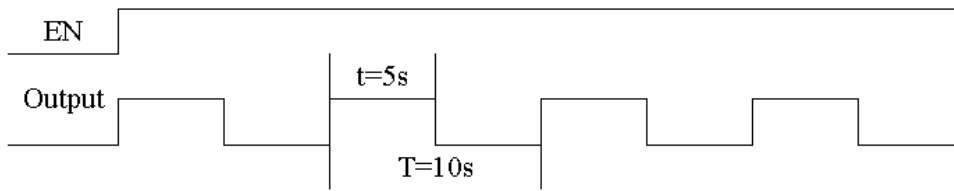

The state of M01, M02 and M03 decide PWM output. PWM stages can be changed by the status of M01, M02 and M03 when P01 is running. ⑥ displays the number of pulse when P01 is running, but ⑥ equals 0 when P01 is disabled.

### PLSY mode

Only P01 can work under this mode, and the output is Q01. PLSY has 6 parameters for proper configuration. The table below describes the information of PLSY parameters.

Symbol	Description
①	PLSY mode (2)
②	Total number of pulse (storing in DRC9)
③	Preset frequency of PLSY (1~1000Hz)
④	Preset pulse number of PLSY(0~32767)
⑤	Output port (Q01)
⑥	PWM code (P01)

The preset frequency and pulse number could be constant or other function current value. They are variable if the preset are other data code. The PLSY will stop output if it has outputted the number of ④ pulse. PLSY will run again if it is enabled for a second time.

Example:

Parameter setting: ③ = 500Hz, ④ = 5, output as shown below:

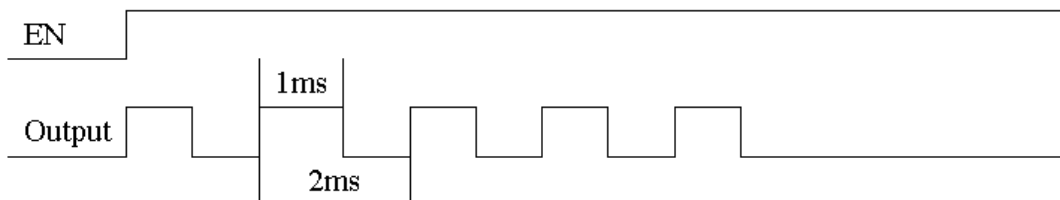

PLSY stops outputting when the number of output pulse is completed.

In the example below, the frequency is other data code (C01). So the wave's frequency will change following the current value of C01.

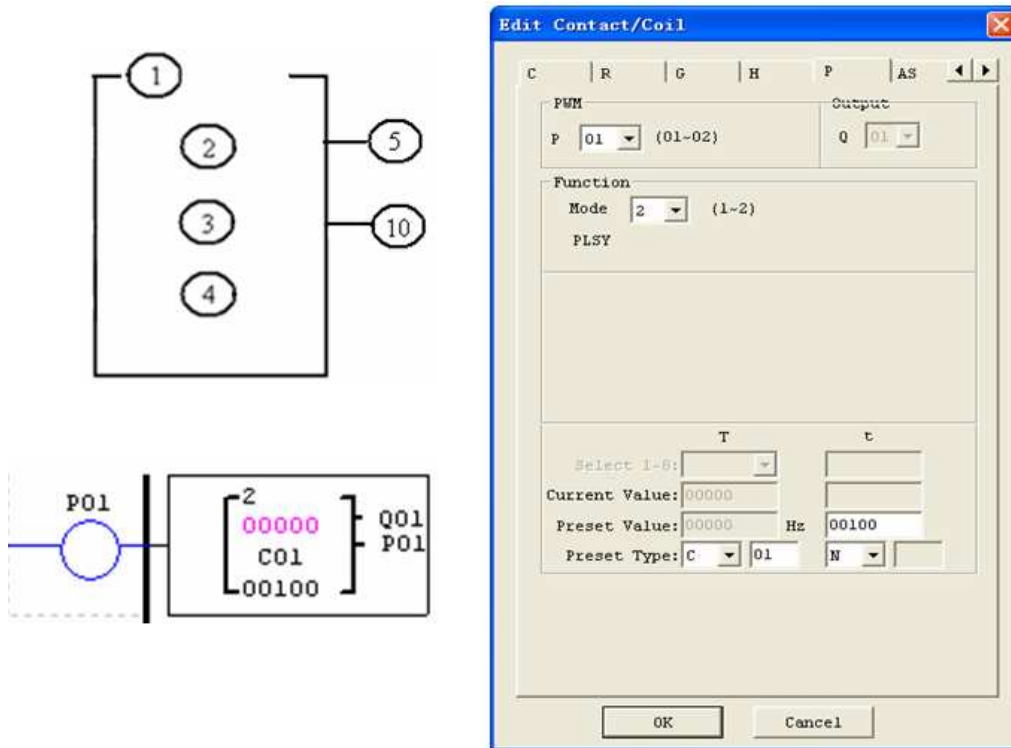

- ✘ In the example above, frequency is 1000 if the current value of C01 is bigger than 1000.
- ✘ PLSY stops outputting pulse after it has output 100 pulses.
- ✘ PLSY will be going on as long as it's enabled if ④ is 0.

**Data Link/Remote I/O Instruction (SMT-CDxx model only)**

The SMT-CDxx models include the capability to link additional SMT-CDxx units via the RS-485 connection terminals. The baud rate and communication format both can be set using the **Operation>Module System Set** menu selection from the SMT Client software. They also can be set through keypad like adjacent picture. The two bits of keypad how to decide the communication format and baud rate like describing below.

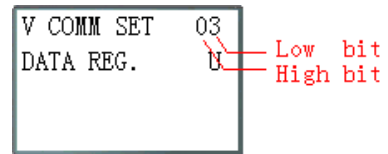

	Data	Parameters
High bit	0	8/N/2 Data 8bit, No Parity, 2 Stop bit.
	1	8/E/1 Data 8bit, Even Parity, 1 Stop bit.
	2	8/O/1 Data 8bit, Odd Parity, 1 Stop bit.
	3	8/N/1 Data 8bit, No Parity, 1 Stop bit.
Low bit	0	4800bps
	1	9600bps
	2	19200bps
	3	38400bps
	4	57600bps
	5	115200bps

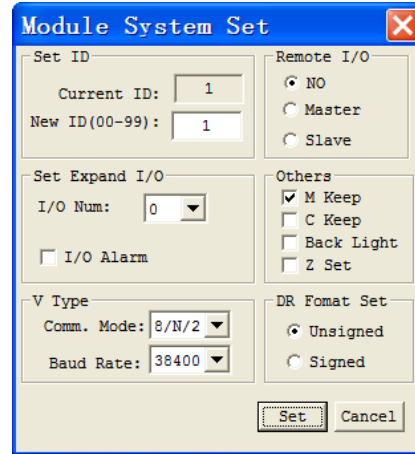

**Data Link**

Up to 8 additional SMT units can be configured as independent Slave nodes, each running their own logic program and their I/O linked to one Master smart relay. The Master smart relay's ID must be 00, and Slave nodes' ID should start with 01 and be continuous. If nodes' ID isn't continuous, the Master won't communication with those nodes which are behind the first broken. For example, the nodes' ID is 01, 02, 04 and 05. The Master thinks there are only two Slave nodes whose ID is 01 and 02, and communication with them.

- max. 8 points I/O send per stations
  - Max 7\*8 (=56) points I/O received per station
- ID must set to be 0,1,2,... (max to 7)**      **Remote I/O disable**

ID	Memory list location
0	W01~W08
1	W09~W16
2	W17~W24
3	W25~W32
4	W33~W40
5	W41~W48
6	W49~W56
7	W57~W64

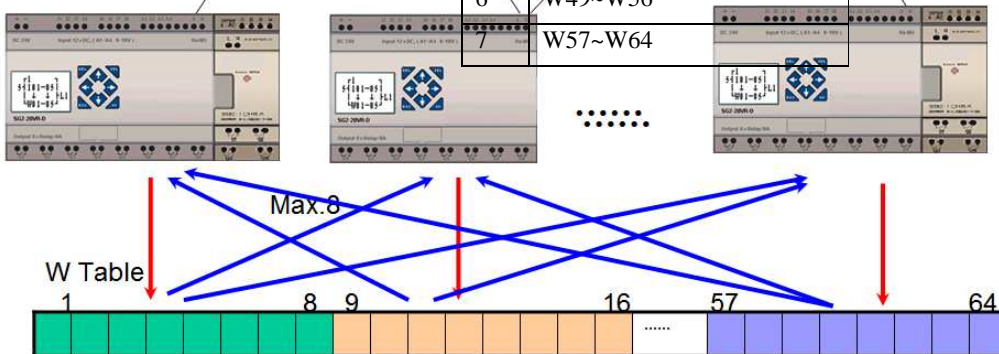
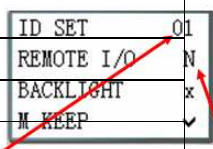

The Mode 1 Send memory range is determined by the Controller ID. Each controller ID is allocated a range of 8 I/O points (Wxx - Wxx) that can be read into the Master smart relay using a Data Link instruction. The adjacent table show the memory range of Wxx locations associated with each controller ID.

Symbol	Description	Type of points	Range
①	Setting mode(1,2) 1:sending 2:receiving	Inputs	I01~I0C/i01~i0C
②	Number of send/receive points (1~8)	Outputs	Q01~Q08/q01~q08
③	Type of send/receive points	Auxiliary coil	M01~M3F/m01~m3F
④	Send/Receive W Table list location	Expansion inputs	X01~X0C/x01~x0C
⑤	I/O link output terminal (L01~L08)	Expansion outputs	Y01~Y0C/y01~y0C

※ Only one Data Link instruction can work at Mode 1, and the other Data Link instructions must be Mode 2.

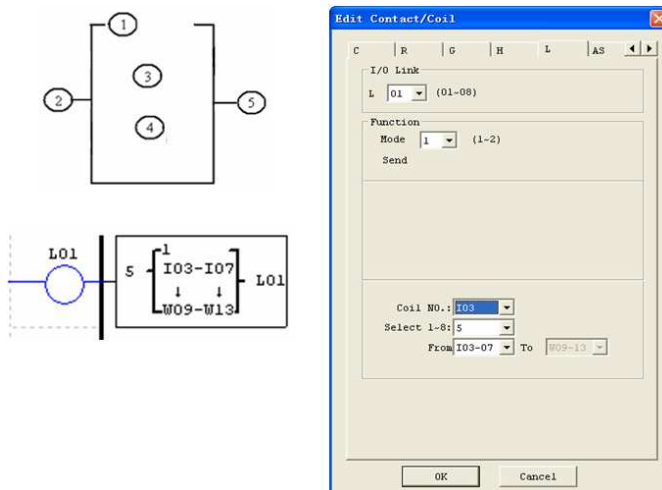

### Example 1: Data Link Mode 1

Set ① = 1, ② = 5, set ③ as the initiate of I03, the state of actual sending terminal I03~I07 is sent to memory list; the controller ID = 1, the state of corresponding memory list position W09~W13, and relationship of sending terminal is as below:

①=1, ② = 5, ③ = I03~I07, ID=1 (④:W09~W13)								
Memory List Position	W09	W10	W11	W12	W13	W14	W15	W16
Corresponding receiving	↑	↑	↑	↑	↑	↑	↑	↑
Or sending terminal	I03	I04	I05	I06	I07	0	0	0

### Example 2: Data Link Mode 2

Set ① = 2, ② = 5, set ③ as start from M03, set ④ as from W17, when enabling the Data Link, the state “ON/OFF” of M03~M07 is controlled by the state of memory list position W17~W21.

	①=1, ② = 5, ③ = M03~M07, ④:W17~W21
Memory List Position	W17 W18 W19 W20 W21
Corresponding receiving	↓ ↓ ↓ ↓ ↓
Or sending terminal	M03 M04 M05 M06 M07

### Remote I/O

Up to 2 additional SMT units can be configured as Remote I/O nodes, and linked to one master smart relay.

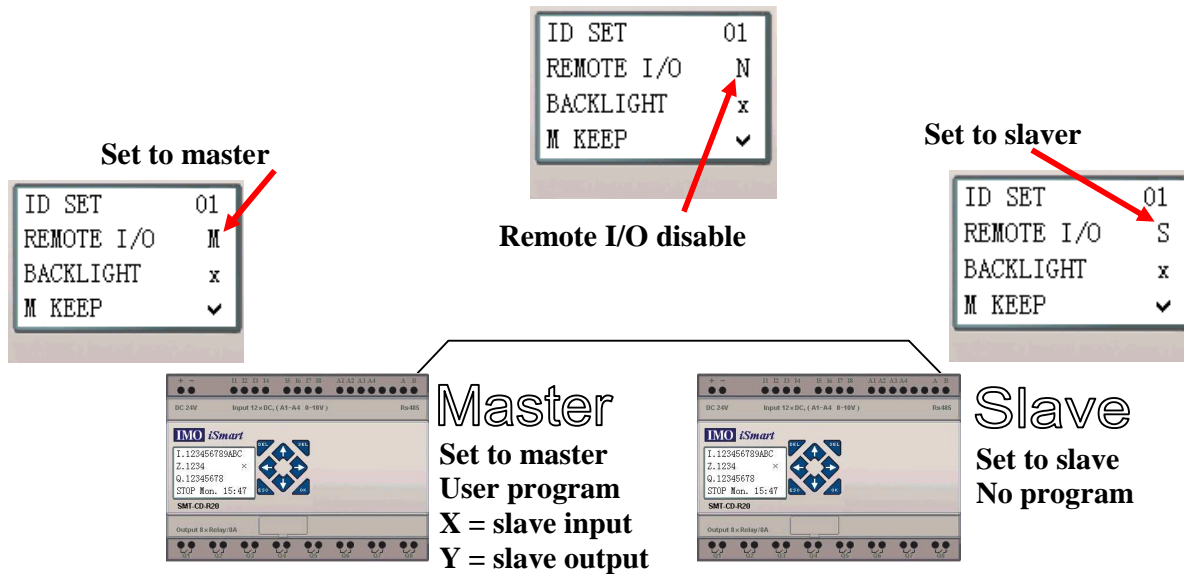

**Don't use expansion DI/DO modules, when remote I/O function is enabled.**

## SHIFT (shift output)

The ISmart relay includes only one SHIFT instruction that can be used throughout a program. This function outputs a series of pulses on selection points depending on the SHIFT input pulse. It has 4 parameters for proper configuration. The table below describes each configuration parameter, and lists each compatible memory type for configuring SHIFT.

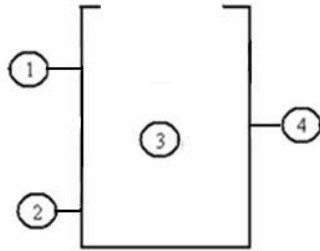

Symbol	Description
①	Preset number of output pulse (1~8)
②	SHIFT input coil (I01~g1F)
③	SHIFT output coils (Q, Y, M, N)
④	SHIFT code (S01)

In the example below, ① = 5, ② = I01, ③: Q03~Q07.

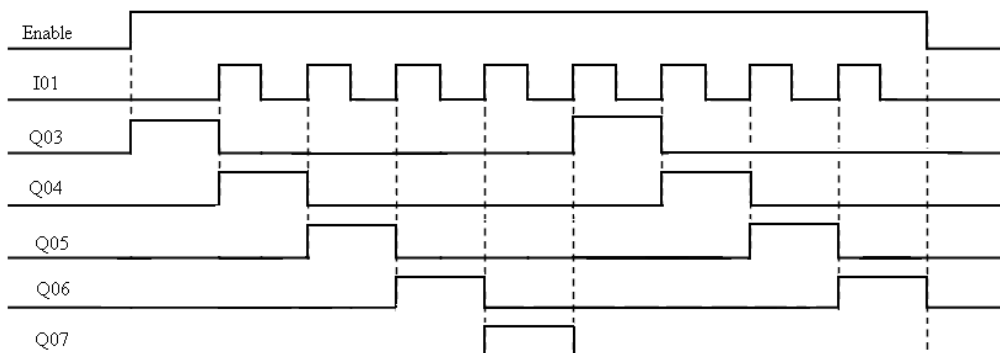
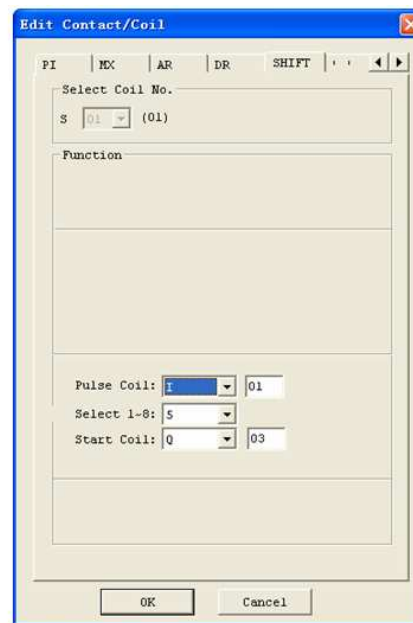
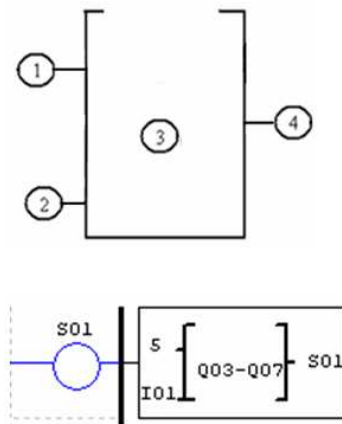

※ Q03 is ON, and from Q04 TO Q07 are OFF when ENABLE is active. Q04 turns ON when I01's rising edge comes on, and other points turn OFF. The next coil turns ON at each rising edge of the SHIFT input, and others turn OFF.



## AQ (Analogue Output)

The default output mode of AQ is 0-10V voltage, the corresponding value of AQ is 0~1000. It also can be set as 0-20mA current, the corresponding value of AQ is 0~500. The output mode of AQ is set by the current value of DRD0~DRD3 as shown below.

Number	Signification	Mode	DRD0~DRD3 data definition
DRD0	Setting the output of AQ01	1	0: voltage mode, AQ output value is 0 under STOP mode
DRD1	Setting the output of AQ02	2	1: current mode, AQ output value is 0 under STOP mode
DRD2	Setting the output of AQ03	3	2: voltage mode, AQ keeps output value under STOP mode
DRD3	Setting the output of AQ04	4	3: current mode, AQ keeps output value under STOP mode

※ It will be thought as 0 if the value of DR isn't in the range of 0~3. That means the output mode of AQ is mode 1. AQ displays preset value (constant of code of other data) under STOP mode, displays current value under RUN mode. AQ preset value can be a constant or other function current value.

## AQ display

AQ displays the preset value under STOP mode, and displays the current value under RUN mode.

2 number of expansion analogue output 2AO, AQ01~AQ04

AQ01 = 01.23 V	0~10VDC voltage mode (AQ value: 0~1000), depending on DRD0
AQ02 = 08.92 mA	0~20mA current mode (AQ value: 0~500), depending on DRD1
AQ03 = AQ01 V	
AQ04 = DR3F mA	

The value will be judged if it's over-flow when writing AQ preset value or current value through PC communication. So, output mode information should have been written before preset value.

AQ is current mode:

$$AQ\_current\_value : 500 = AQ\_display\_value : 20.00mA$$

AQ current value is different from display value, and current value is used in operation and storage.

AQ display is shown below.

**AQ Set** [X]

Set		Mode	
AQ01	N	0100	1
AQ02	N	0100	2
AQ03	N	0200	3
AQ04	N	0200	4

Current mode, keep value when stop

OK Cancel

Display →

AQ01=01.00V  
AQ02=04.00mA  
AQ03=02.00V  
AQ04=08.00mA

## AS (Add-Subtract)

The ISmart relay includes a total of 31AS instructions that can be used throughout a program. The ADD-SUB Addition and/or Subtraction function enables simple operations to be carried out on integers. There are 6 parameters for proper configuration. The table below describes each configuration parameter, and lists each compatible memory type for configuring AS.

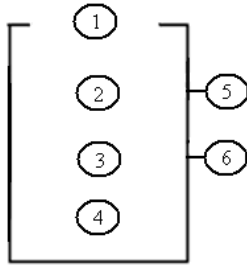

Symbol	Description
①	AS current value ( -32768~32767)
②	V1 parameter ( -32768~32767)
③	V2 parameter ( -32768~32767)
④	V3 parameter ( -32768~32767)
⑤	Error output coil (M, N, NOP)
⑥	AS code (AS01~AS1F)

**Compute formula:**  $AS = V1 + V2 - V3$

AS current value is the result of compute. Parameters V1, V2, and V3 can be a constant or other function current value. The output coil will be set to 1 when the result is overflow. And the current value is no meaning at this time. But it will do nothing if the output coil is NOP. The output coil will turn OFF when the result is right or the function is disabled.

The example below shows how to configure AS function.

※ Error output coil N01 will turn ON when the compute result is overflow.

## MD (MUL-DIV)

The ISmart relay includes a total of 31MD instructions that can be used throughout a program. The MUL-DIV Multiplication and Division function enables simple operations to be carried out on integers.

There are 6 parameters for proper configuration. The table below describes each configuration parameter, and lists each compatible memory type for configuring MD.

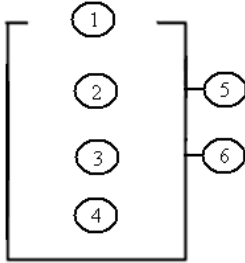

Symbol	Description
①	MD current value ( -32768~32767)
②	V1 parameter ( -32768~32767)
③	V2 parameter ( -32768~32767)
④	V3 parameter ( -32768~32767)
⑤	Error output coil (M, N, NOP)
⑥	MD code (MD01~MD1F)

**Compute formula:**  $MD = V1 * V2 / V3$

MD current value is the result of compute. Parameters V1, V2, and V3 can be a constant or other function current value. The output coil will be set to 1 when the result is overflow. And the current value is no meaning at this time. But it will do nothing if the output coil is NOP. The output coil will turn OFF when the result is right or the function is disabled.

The example below shows how to configure MD function.

✘ Error output coil M01 will turn ON when the compute result is overflow.

### PID (Proportion- Integral- Differential)

The ISmart relay includes a total of 15 PID instructions that can be used throughout a program. The PID function enables simple operations to be carried out on integers. There are 9 parameters for proper configuration. The table below describes each configuration parameter, and lists each compatible memory type for configuring PID.

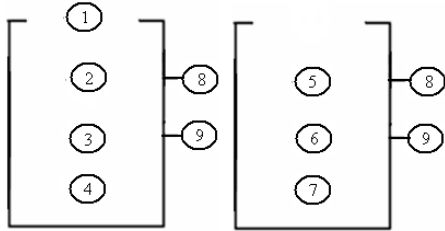

Symbol	Description
<input type="checkbox"/>	PI: PID current value (-32768~32767)
<input type="checkbox"/>	SV: target value (-32768~32767)
<input type="checkbox"/>	PV: measure value (-32768~32767)
<input type="checkbox"/>	T <sub>S</sub> : sampling time (1~32767 * 0.01s)
<input type="checkbox"/>	K <sub>P</sub> : Proportion (1~32767 %)
<input type="checkbox"/>	T <sub>I</sub> : Integral time (1~32767 * 0.1s)
<input type="checkbox"/>	T <sub>D</sub> : Differential time (1~32767 * 0.01s)
<input type="checkbox"/>	Error output coil (M, N, NOP)
<input type="checkbox"/>	PID code (PI01~PI0F)

The parameters from  to  can be constant or other function current value. The error coil will turn ON when either T<sub>S</sub> or K<sub>P</sub> is 0. But it will do nothing if the output coil is NOP. The output coil will turn OFF when the result is right or the function is disabled.

#### PID computes formula:

$$EV_n = SV - PV_n$$

$$\Delta PI = K_p \left\{ (EV_n - EV_{n-1}) + \frac{T_s}{T_i} EV_n + D_n \right\}$$

$$D_n = \frac{T_D}{T_S} (2PV_{n-1} - PV_n - PV_{n-2})$$

$$PI = \sum \Delta PI$$

The example below shows how to configure PID function.

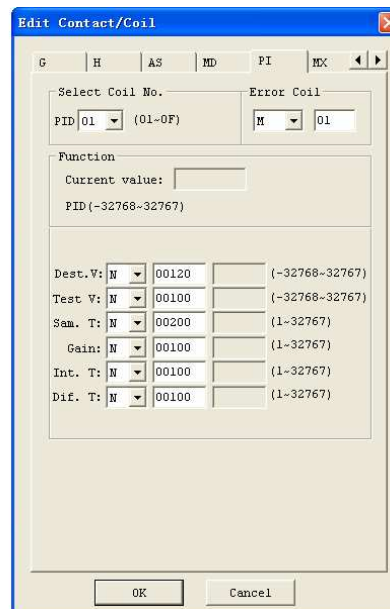
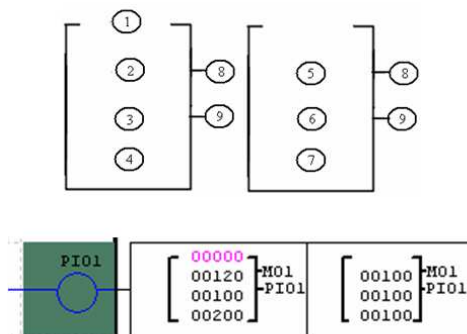

## MX (Multiplexer)

The ISmart relay includes a total of 15 MX instructions that can be used throughout a program. This special function transmits 0 or one of 4 preset values to MX current value memory. The MX function enables simple operations to be carried out on integers. There are 7 parameters for proper configuration. The table below describes each configuration parameter, and lists each compatible memory type for configuring MX.

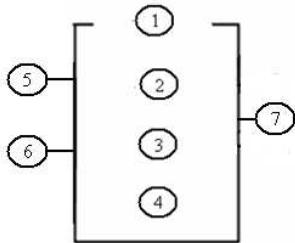

Symbol	Description
<input type="checkbox"/>	V1 parameter ( -32768~32767)
<input type="checkbox"/>	V2 parameter ( -32768~32767)
<input type="checkbox"/>	V3 parameter ( -32768~32767)
<input type="checkbox"/>	V4 parameter ( -32768~32767)
<input type="checkbox"/>	Selection bit 1: S1
<input type="checkbox"/>	Selection bit 2: S2
<input type="checkbox"/>	MX code (MX01~MX0F)

The parameters from  to  can be constant or other function current value. The table below describes the relationship between parameter and MX current value.

Disable	MX = 0;
Enable	S1 = 0, S2 = 0: MX = V1; S1 = 0, S2 = 1: MX = V2; S1 = 1, S2 = 0: MX = V3; S1 = 1, S2 = 1: MX = V4;

The example below shows how to configure MX function.

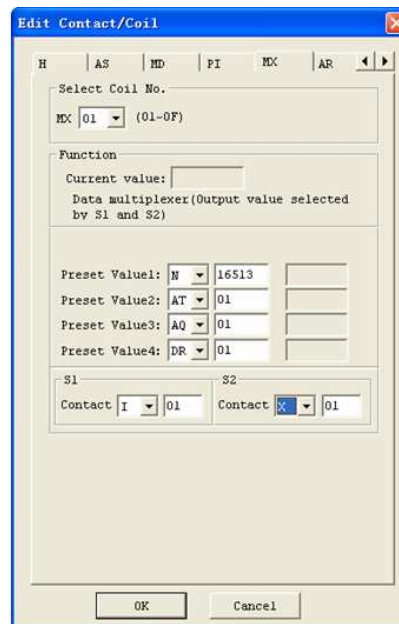
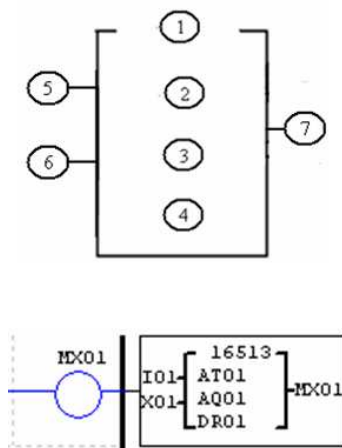

## AR (Analogue-Ramp)

The ISmart relay includes a total of 15 AR instructions that can be used throughout a program. The AR function enables simple operations to be carried out on integers. Analogue Ramp instruction allows AR current level to be changed by step from starting level to target level at a specified rate. There are 12 parameters for proper configuration. The table below describes each configuration parameter, and lists each compatible memory type for configuring AR.

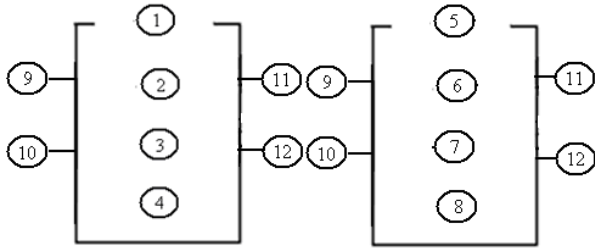

$$AR\_current\_value = (AR\_current\_level - B) / A$$

Symbol	Description
①	AR current value: 0~32767
②	Level1:-10000~20000
③	Level2:-10000~20000
④	MaxL (max level):-10000~20000
⑤	start/stop level (StSp): 0~20000
⑥	stepping rate (rate): 1~10000
⑦	Proportion (A): 0~10.00
⑧	Excursion (B): -10000~10000
⑨	Level selection coil (Sel)
⑩	Stop selection coil (St)
(11)	Error output coil (M, N, NOP)
(12)	AR code (AR01~AR0F)

The parameters from ② to ⑧ can be constant or other function current value. The table below describes detail information of each parameter of AR.

Sel	Selection level Sel = 0: target level = Level1 Sel = 1: target level = Level2 ✘ MaxL is used as target level if the selected level is bigger than MaxL.
St	Selection stop coil. The St's state becomes from 0 to 1 will startup the current level decrease to start/stop level (StSp + excursion "B"), and then keep this level for 100ms. Then AR current level is set to B which will make AR current value equals 0.
Output coil	The output coil turns ON when A is 0.

✘ The output coil can be M, N or NOP. The output coil is set when the wrong thing happens, but it will do nothing if the output coil is NOP. And the current value is no meaning at this time.

AR will keep the current level at "StSp + Offset "B"" for 100ms when it's enabled. Then the current level runs from StSp + Offset "B" to target level at enactment Rate. If St is set, the current level decreases from current level to level StSp + B at enactment Rate. Then AR holds the level StSp + Offset "B" for 100ms. After 100ms, AR current level is set to offset "B", which makes AR current value equals 0.

## Timing diagram for AR

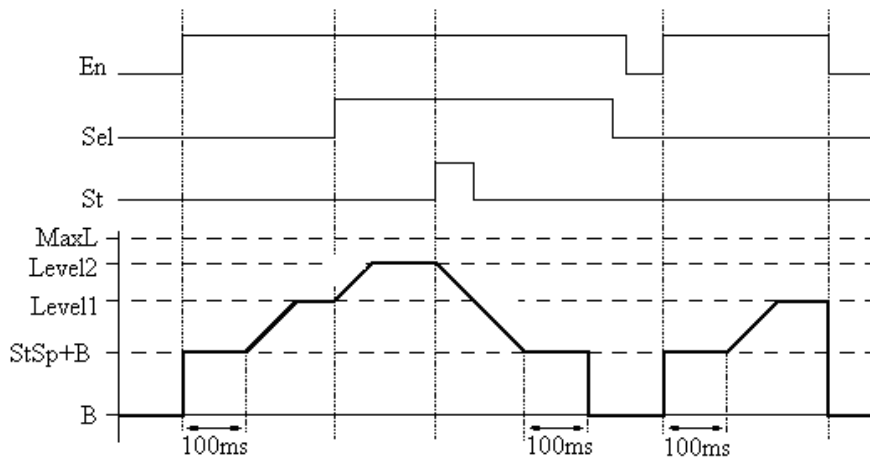

The example below shows how to configure AR function.

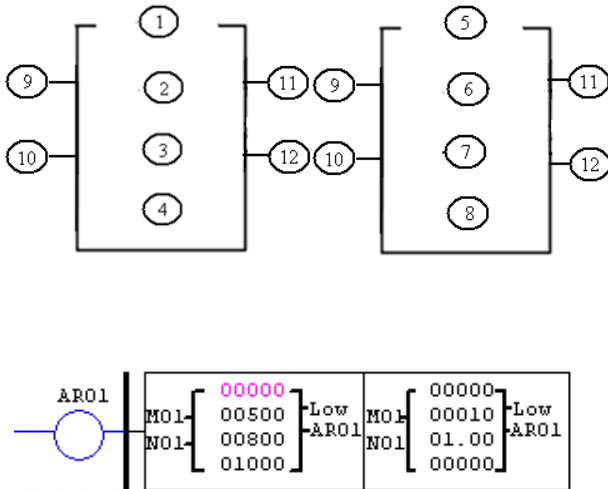

**Edit Contact/Coil**

AS MD PI MX **AR** DR

Select Coil No. AR  (01~0F) Error Coil

Function

Current value:

AR = (Level - Offset) / Gain

Level1:	N	00500		(-10000~20000)
Level2:	N	00800		(-10000~20000)
MaxL:	N	01000		(-10000~20000)
StSp:	N	00000		(0~20000)
Rate:	N	00010		(1~10000)
Gain:	N	01.00		(0~10.00)
Offset:	N	00000		(-10000~10000)

Sel Contact   St Contact

OK Cancel



## DR (Data register)

The ISmart relay includes a total of 240 DR instructions that can be used throughout a program. The DR function is transferring data. DR is a temp register. DR sends data from prevention registers to current register when it's enabled. The data can be sign or unsigned by setting DR\_SET bit through **operation>>module system set** menu selection from the SMT Client software. There are 2 parameters for proper configuration. The table below describes each configuration parameter, and lists each compatible memory type for configuring DR.

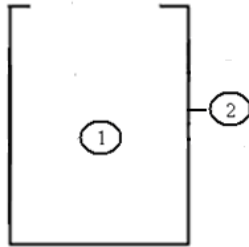

Symbol	Description
①	Preset value: DR_SET = 0, 0~65535 DR_SET = 1,-32768~32767
②	DR code (DR01~DRF0)

The parameter ① can be a constant or other function current value.

The example below shows how to configure DR function.

STOP	RUN (DR01 = C01 current value)
<pre>DR01= C01 DR02= 00000 DR03= 00000 DR04= 00000</pre>	<pre>DR01= 00009 DR02= 00000 DR03= 00000 DR04= 00000</pre>

The data registers from DR65 to DRF0 will be kept when the smart powers down. The last 40 DR that from DRC9 to DRF0 are special data register as shown below. The content of DRC9 is PLSY'S total number of pulse, and DRD0~DRD3 are output mode registers of AQ01~AQ04, and DRCA~ DRCF, DRD4~ DRF0 are reserved.

DRC9	PLSY total number
DRCA~DRCF	reserved
DRD0	AQ01 output mode register
DRD1	AQ02 output mode register
DRD2	AQ03 output mode register
DRD3	AQ04 output mode register
DRD4~DRF0	reserved

**MU (MODBUS) (only CD type model)**

MODBUS function carries out Modbus RTU master communication for the RS485 port. There are 15 MODBUS functions: MU01~MU0F. Remote IO and Data Link have precedence over MODBUS. MODBUS is executed also when the system setting is N (No Remote IO) and ID isn't 0.

ID SET	01
REMOTE I/O	N
BACKLIGHT	x
M KEEP	✓

When the MU function is activated; it takes possession of the RS485 communication port, releasing the port when disabled and one MODBUS cycle period is completed. There can be a number of MU communication orders in one program, but only one can be activated at any one time.

Function mode corresponding communication function code:

Mode	Communication function code
1	03 (read registers)
2	06 (write single register)
3	10 (write some registers)
4	01 (read coils)
5	05 (write single coil)

The coil used in MODBUS function:

Received (M3D)	M3D is set to ON after received, then check-up for error. Transferring data to target address if there is no error.
Error flag (M3E)	communication error flag
Time out flag (M3F)	M3F is set to 1 when the time from after sending to start receiving is longer than setting, and M3D also be set to 1. M3F is automatically reset if M3D reset.

The time out time is depending communication baud rate as shown in the table below:

Baud rate (bps)	Time out (ms)
4800、9600、19200、38400	125
57600	100
115200	80

There are 5 parameters in MODBUS function as shown below.

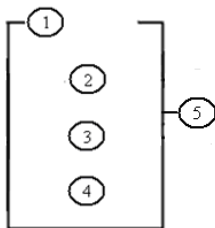





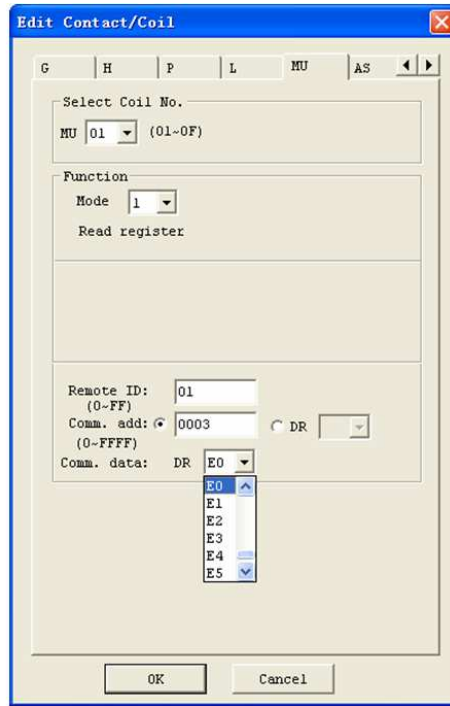
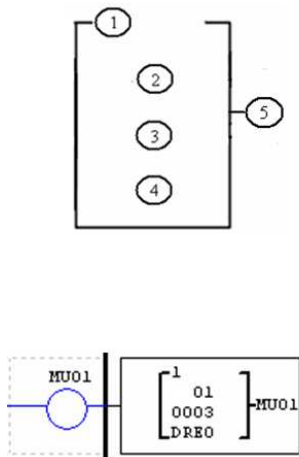

Symbol	Description
①	MODBUS mode (1~5)
②	Communication address: slave ID, range: 0~127
③	Communication content: address and data length: 1) address is constant, range: 0000~ffff; length must be 1 word; 2) DR code, get address and length from this DR and the next
④	DR code, store sending/receiving data from this DR
⑤	MODBUS code (MU01~MU0F)

The example below shows how to configure DR function.



Examples:

mode	display		
1 Read register	<pre> r1      1    01      0003   MU01    DRE0   </pre>	Address is constant: 0003, Length = 1, Send: 01 03 00 03 00 01 CRC16;	Receive: 01 03 02 data1 data2 CRC16, data storage: DRE0= (data1<<8)   data2,
	<pre> r1      1    01      DR03   MU01    DRE0   </pre>	Address is DR03=0001, Length is DR04=0002, Send: 01 03 00 01 00 02 CRC16;	Receive: 01 03 04 data1 data2 data3 data4 CRC16, data storage: DRE0= (data1<<8)   data2, DRE1= (data3<<8)   data4
2 Write single register	<pre> r2      1    01      0003   MU01    DRE0   </pre>	Address is constant: 0003, Length = 1, data storage: DRE0=1234(hex: 04D2), Send: 01 06 00 03 04 D2 CRC16;	Receive: 01 06 00 03 04 D2 CRC16;
	<pre> r2      1    01      DR03   MU01    DRE0   </pre>	Address: DR03=0001, data storage: DRE0=1234(hex: 04D2), Send: 01 06 00 01 04 D2 CRC16;	Receive: 01 06 00 01 04 D2 CRC16;

3 Write register		Address: 0003, Length = 1, data storage: DRE0=1234(hex: 04D2), Send: 01 10 00 03 00 01 02 04 D2 CRC16;	Receive: 01 10 00 03 00 01 CRC16;
		Address: DR03=0001, Length: DR04=0002, data storage: DRE0=1234(hex: 04D2), DRE1=5678(hex: 162E), Send: 01 10 00 01 00 02 04 04 D2 16 2E CRC16;	Receive: 01 10 00 01 00 02 CRC16;
4 Read coil		Address: 0003, Length = 10H, Send: 01 01 00 03 00 10 CRC16;	Receive: 01 01 02 data1 data2 CRC16, data storage: DRE0= (data1<<8)   data2;
		Address: DR03=0001, Length: DR04=0016, Send: 01 01 00 01 00 10 CRC16; <i>Max value in DR04 is 400.</i>	Receive: 01 01 02 data1 data2 CRC16, data storage: DRE0= (data1<<8)   data2;
5 Write single coil		Address: 0003, data storage: DRE0=65280(hex: FF00), Send: 01 05 00 03 FF 00 CRC16;	Receive: 01 05 00 03 FF 00 CRC16;
		Address: DR03=0001, data storage: DRE0=65280(hex: FF00), Send: 01 05 00 01 FF 00 CRC16;	Receive: 01 05 00 01 FF 00 CRC16;

## Chapter 5: Function Block Diagram Programming

### FBD Instructions

	Input	Output coil	Range
Input	I		12 (I01~I0C)
Keypad input	Z		4 (Z01~Z04)
Expansion input	X		12 (X01~X0C)
Output	Q	Q	8 (Q01~Q08)
Expansion output	Y	Y	12 (Y01~Y0C)
Auxiliary coil	M	M	63(M01~M3F)
Auxiliary coil	N	N	63(N01~N3F)
HMI		H	31 (H01~H1F)
PWM		P	2 (P01~P02)
SHIFT		S	1 (S01)
I/O LINK		L	8 (L01~L08)
Logic/Function Block	B	B	260 (B001~B260)
Normal ON	Hi		
Normal OFF	Lo		
No connection	Nop		
Analogue input	A		8 (A01~A08)
Analogue input parameter	V		8 (V01~V08)
Analogue output		AQ	4(AQ01~AQ04)
Analogue temperature input	AT		4(AT01~AT04)

FBD program can only be edited and modified in the SMT Client software and write to SMT controlled equipments via communication cable. Via controlled equipment, FBD program is available for querying or the parameter of the function block of the program for modifying. The preset value of Block could be a constant or other block code. That means the preset value of this block is other block's current value.

✘ Each FBD block's size isn't restricted, it depends its function.

### Coil Block Instruction

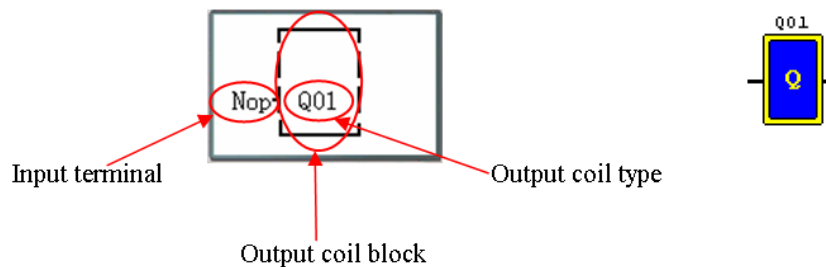

# HMI

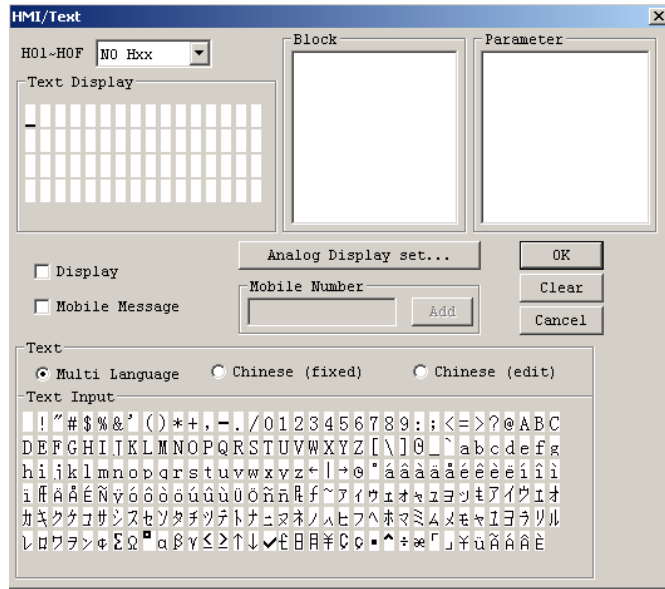
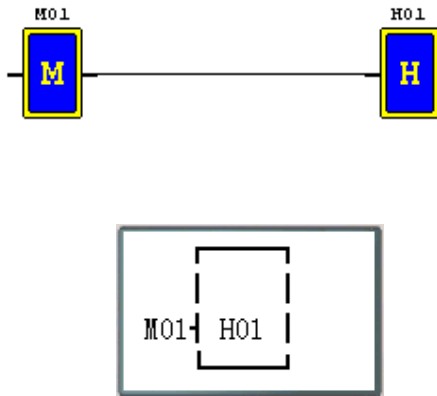

## PWM function block (only transistor output version)

### PWM mode

The PWM output terminal Q01 or Q02 can output 8 PWM waveforms.

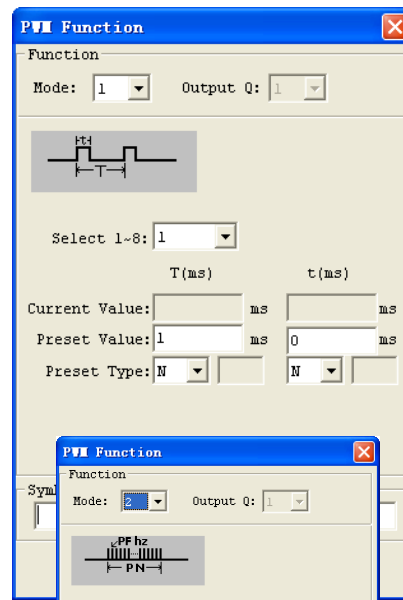
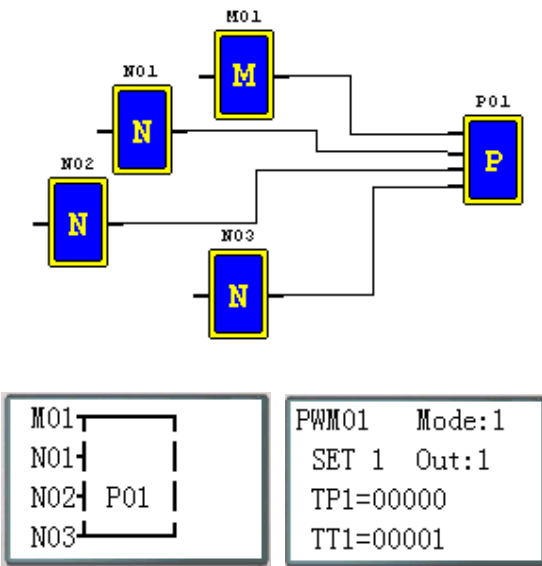

### PLSY mode

The PLSY output terminal Q01 can output preset number of frequency is variable from 1 to 1000 Hz.

pulse whose

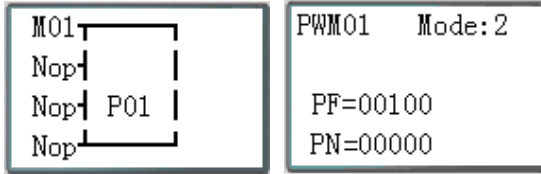
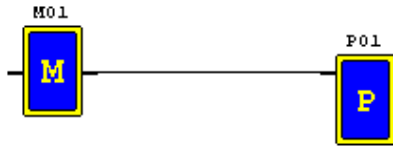

**Data Link function block**

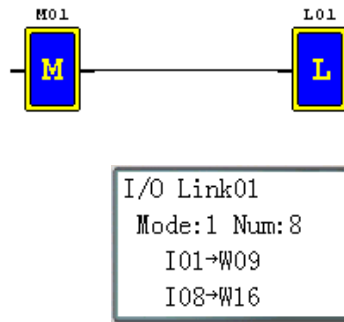

**Link**

Function NO.  Mode  Send  Receive

bits num:

Start Coil:

Start Memory:

Symbol:

**SHIFT function block**

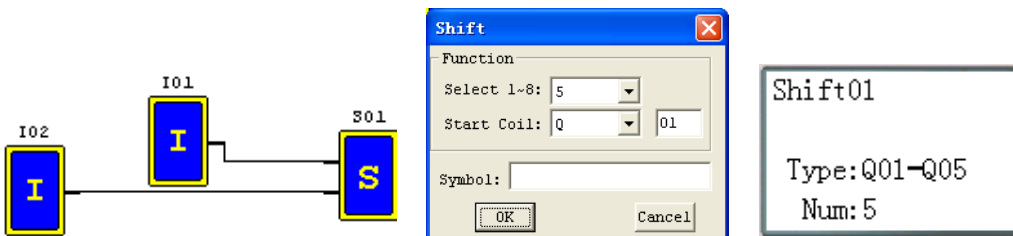



## Timing diagram

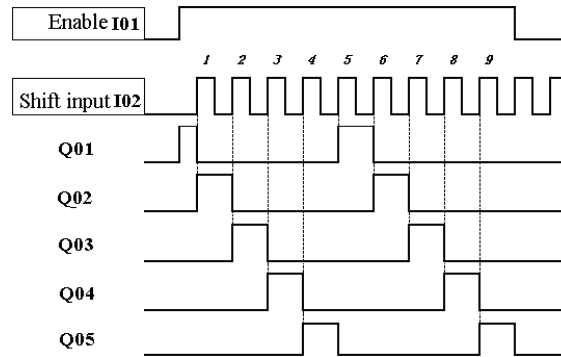

## Logic Block Instructions

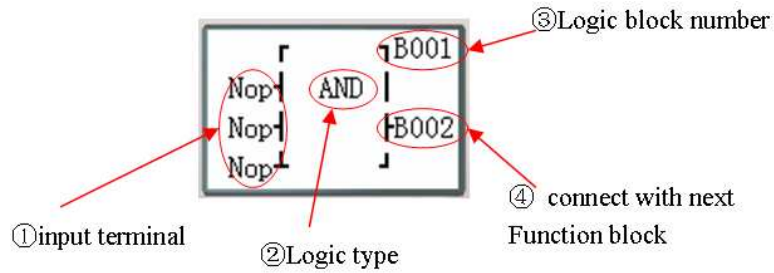

Logic function block source:

	Block	Number(byte)
Total block	260	6000
AND	1	8
AND(EDGE)	1	8
NAND	1	8
NAND(EDGE)	1	8
OR	1	8
NOR	1	8
XOR	1	6
RS	1	6
NOT	1	4
PLUSE	1	4
BOOLEAN	1	12

## AND Logic Diagram

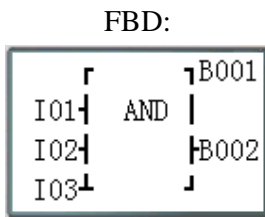

I01 And I02 And I03

Note: The input terminal is NOP which is equivalent to 'Hi'

LADDER:

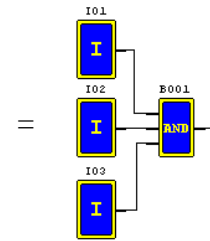
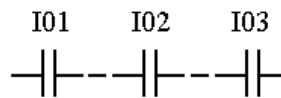

## AND (EDGE) Logic Diagram

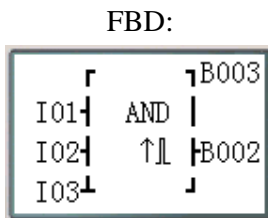

I01 And I02 And I03 And D

Note: The input terminal is NOP which is equivalent to 'Hi'

LADDER:

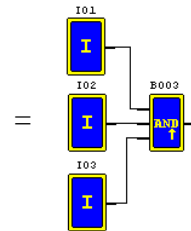
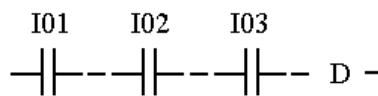

## NAND Logic Diagram

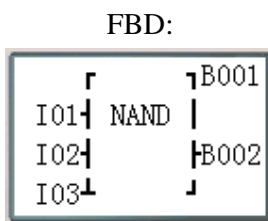

Not(I01 And I02 And I03)

Note: The input terminal is NOP which is equivalent to 'Hi'

LADDER:

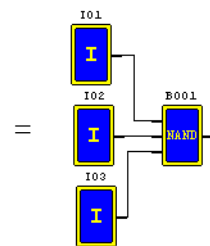
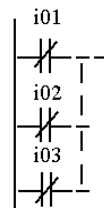

## NAND (EDGE) Logic Diagram

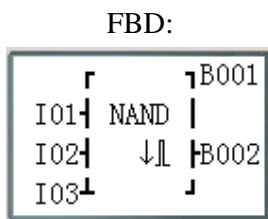

Not(I01 And I02 And I03)

And D

Note: The input terminal is NOP which is equivalent to 'Hi'

LADDER:

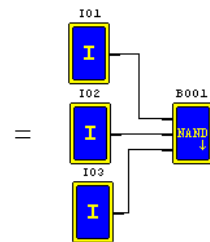
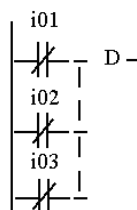

# OR Logic Diagram

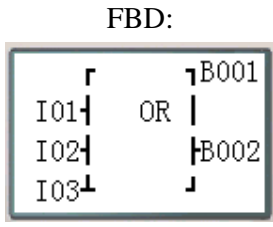

→

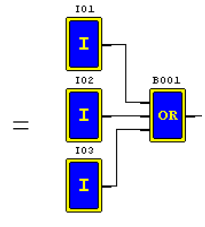
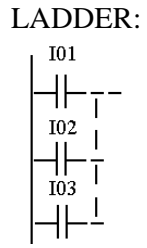

I01 or I02 or I03

**Note:** The input terminal is NOP which is equivalent to 'Lo'

## OR Logic Diagram

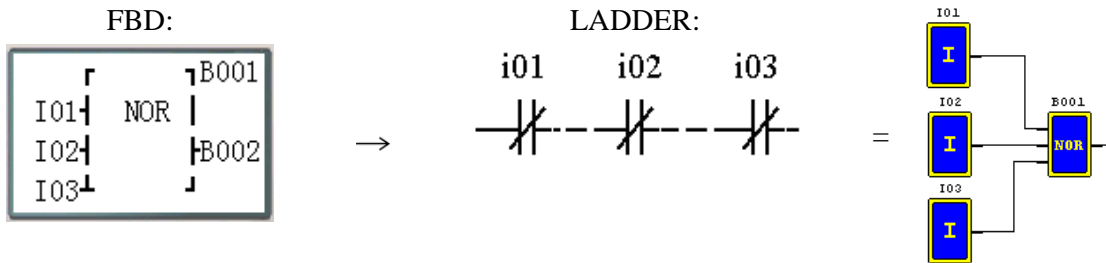

Not ( I01 or I02 or I03 )

Note: The input terminal is NOP which is equivalent to 'Lo'

## XOR Logic Diagram

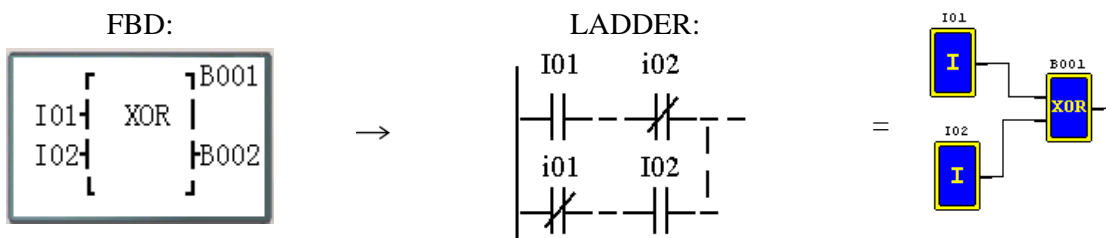

I01 XOR I02

Note: The input terminal is NOP which is equivalent to 'Lo'

## SR Logic Diagram

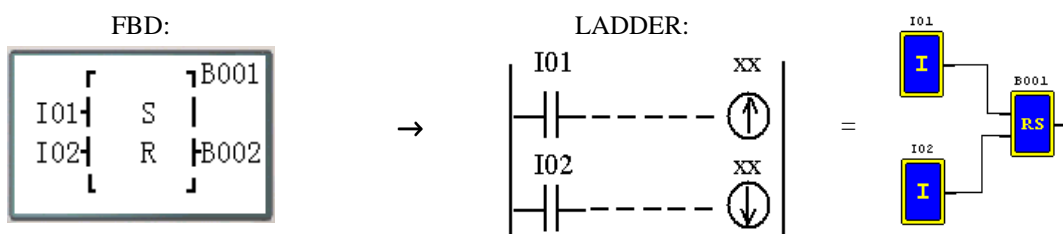

Logic Table

I01	I02	B001
0	0	holding
0	1	0
1	0	1
1	1	0

Note: The input terminal is NOP which is equivalent to 'Lo'

## NOT Logic Diagram

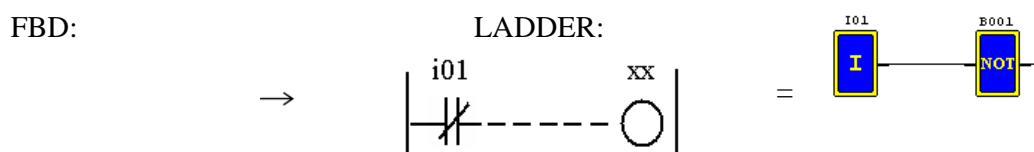

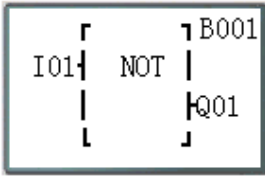

Not I01

Note: The input terminal is NOP which is equivalent to ‘Hi’

## Pulse Logic Diagram

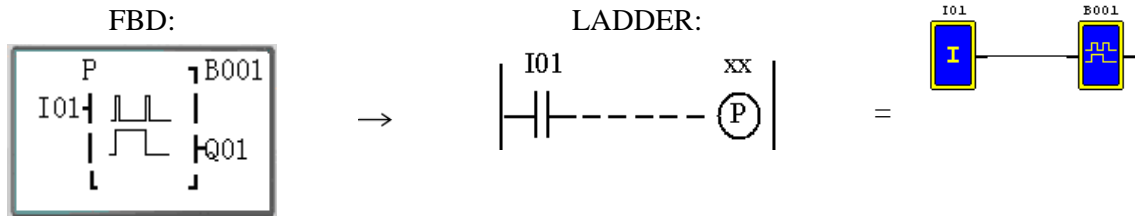

Note: The input terminal is NOP which is equivalent to “Lo”

## BOOLEAN Logic Diagram

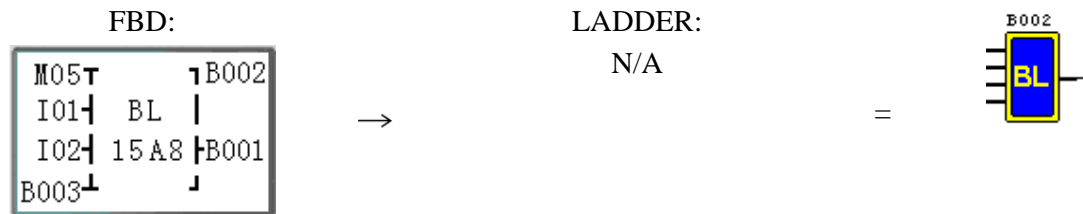

Note: The input terminal is NOP which is equivalent to “Lo”

Description:

Input1	M 0 5	┐	┐ B x x x	block code
Input2	I 0 1	└	B L	
Input3	I 0 2	└	1 5 A 8	└ B y y y real table; output
Input4	B 0 0 3	└	└	

The relationship between input and real table is shown below.

Input1	Input2	Input3	Input4	Output (edit)	Example	Real table
0	0	0	0	0/1	0	8
1	0	0	0	0/1	0	
0	1	0	0	0/1	0	
1	1	0	0	0/1	1	
0	0	1	0	0/1	0	A
1	0	1	0	0/1	1	
0	1	1	0	0/1	0	
1	1	1	0	0/1	1	
0	0	0	1	0/1	1	5
1	0	0	1	0/1	0	
0	1	0	1	0/1	1	
1	1	0	1	0/1	0	
0	0	1	1	0/1	1	1
1	0	1	1	0/1	0	
0	1	1	1	0/1	0	
1	1	1	1	0/1	0	

## Function Block

Function Block includes three kinds of function: special function, adjust-controlling function and communication function. Function type and number are shown in the table below.

	Function type	Number
<b>Special function</b>	Timer	250
	Counter	250
	RTC	250
	Analogue Comparator	250
<b>Adjust-controlling function</b>	AS	250
	MD	250
	PID	30
	MX	250
	AR	30
	DR	240
<b>Communication function</b>	MU	250

The capability of each block is alterable, it depends the type of function. There are total of 260 blocks, and the total capability of block area is 6000 bytes. For example, the block is Timer mode 7, the block size is 12 bytes.

Source table:

	Block	Number (byte)	Timer	Counter	RTC	Analogue comparator	AS	MD	PID	MX	AR	DR	MU
Total source	260	6000	250	250	250	250	250	250	30	250	30	240	250
Timer mode0	1	5	1										
Timer mode1~6	1	10	1										
Timer mode7	1	12	2										
Counter mode0	1	5		1									
Counter mode1~7	1	14		1									
Counter mode8	1	16		1									
RTC mode0	1	5			1								
RTC mode1~4	1	11			1								
Analogue mode0	1	5				1							
Analogue mode1~7	1	12				1							
AS	1	11					1						
MD	1	11						1					
PID	1	17							1				
MX	1	17								1			
AR	1	23									1		
DR	1	6										1	
MU	1	12											1

Function displaying:

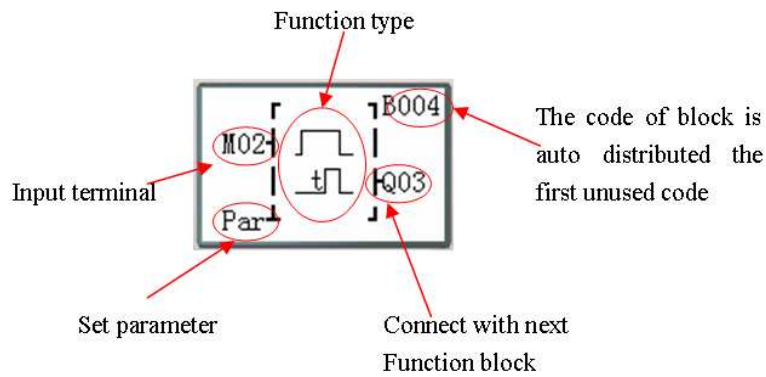

## Timer Function Block

T0E and T0F keep their current value after a loss of power to the smart relay if “M Keep” is active. But the other Timers’ current value is 0.

(1) Timer mode 0 (Internal coil Mode)

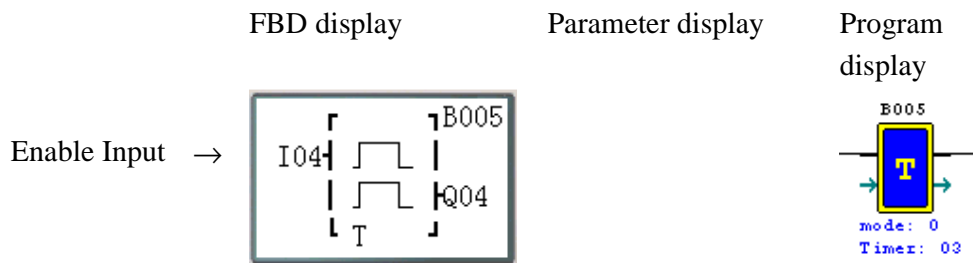

(2) Timer mode 1 (ON-Delay A Mode)

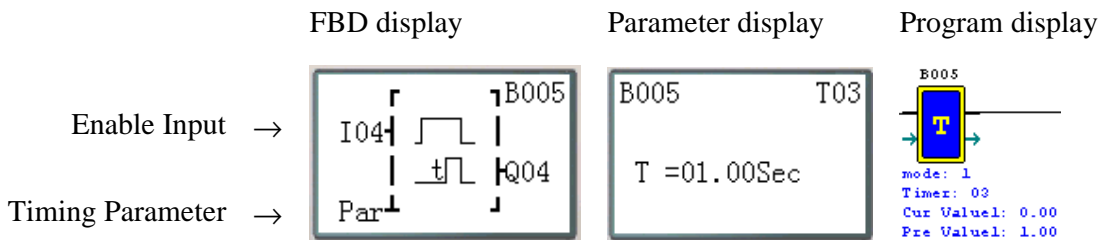

(3) Timer mode 2 (ON-Delay B Mode)

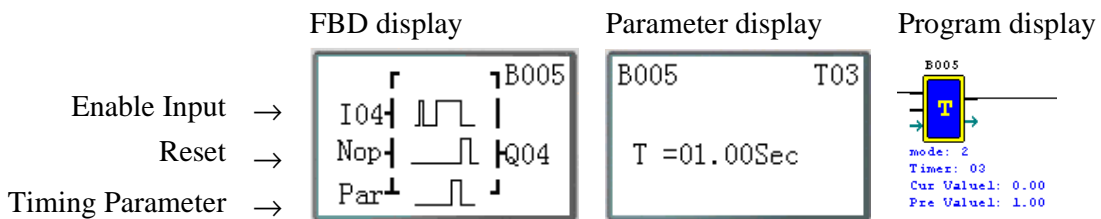

(4) Timer mode 3 (OFF-Delay A Mode)

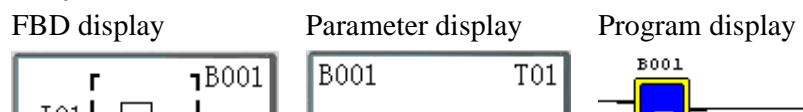



Enable Input →  
 Reset →  
 Timing Parameter →

(5) Timer mode 4(OFF-Delay B Mode)

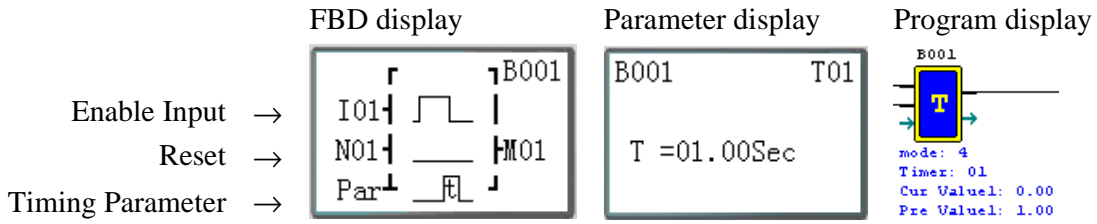

(6) Timer mode 5(FLASH A Mode)

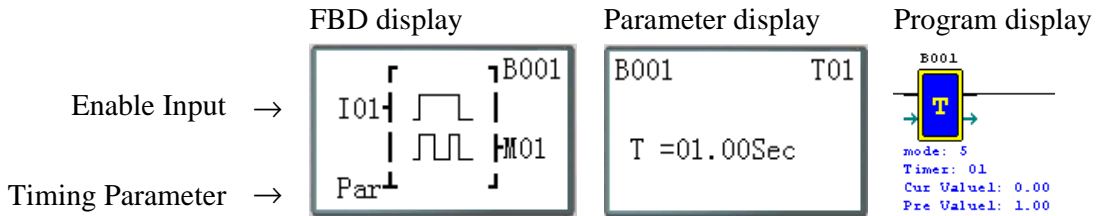

(7) Timer mode 6(FLASH B Mode)

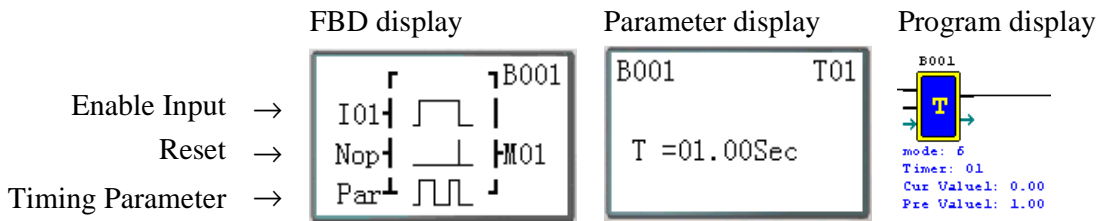

(8) Timer mode 7(FLASH C Mode)

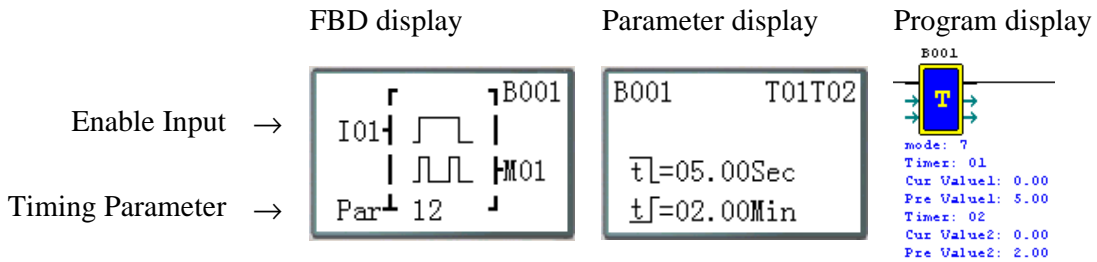

## Common Counter function block

### (1) Counter Mode 0

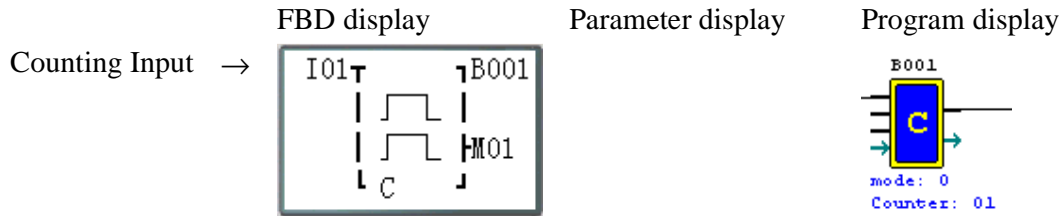

### (2) Counter Mode 1

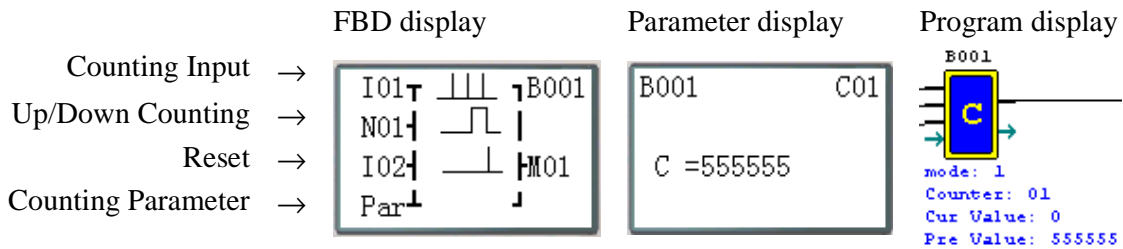

### (3) Counter Mode 2

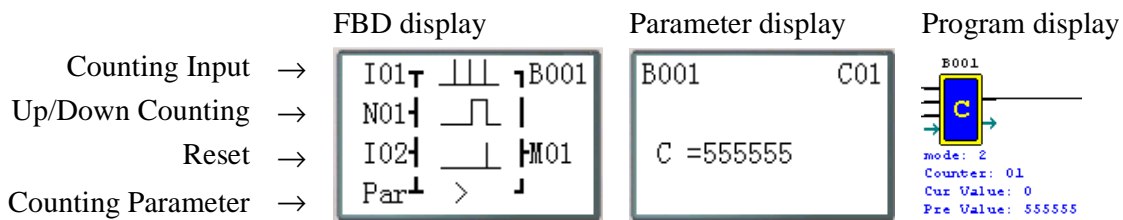

Note: The “>” means the current value appeared will be greater than present value.

### (4) Counter Mode 3

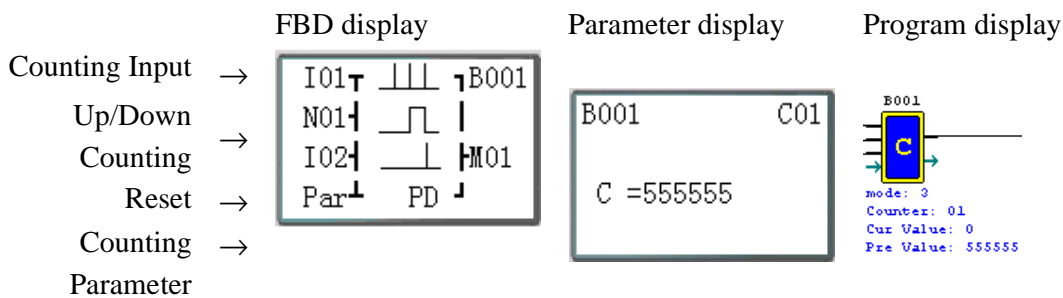

Note: The “PD” means the current value will be retain until the power recover;  
Counter keeps current value when the smart switches between RUN and STOP when C KEEP enable;

### (5) Counter Mode 4

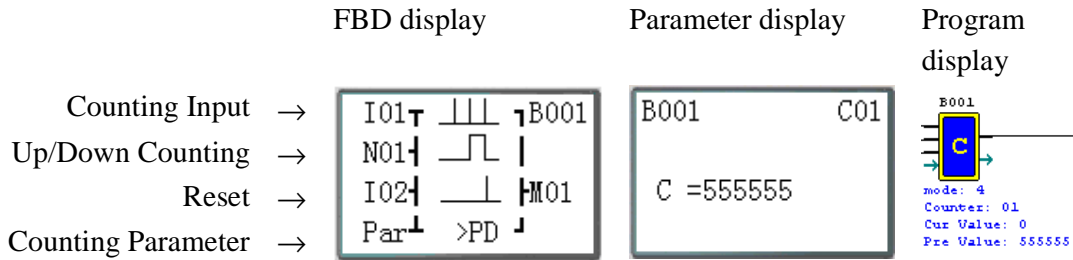

Note: The “>” means the current value appeared will be greater than present value;

The “PD” means the current value will be retain until the power recover; Counter keeps current value when the smart switches between RUN and STOP when C KEEP enable;

### (6) Counter Mode 5

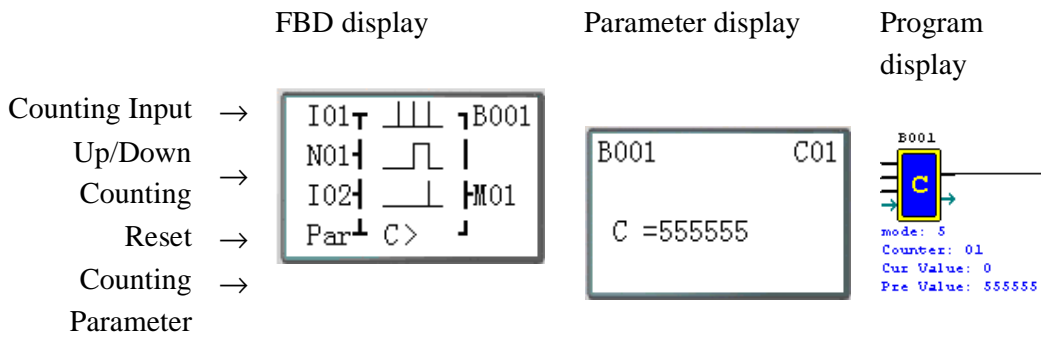

Note: The “>” means the current value appeared will be greater than present value.

### (7) Counter Mode 6

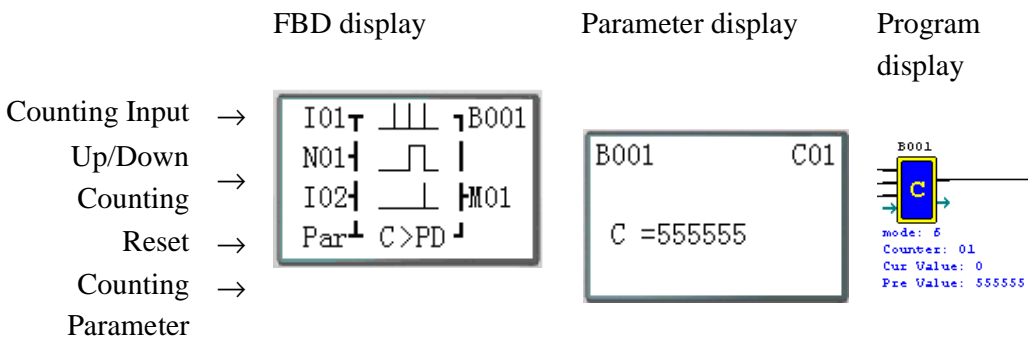

Note: The “>” means the current value appeared will be greater than present value;

The “PD” means the current value will be retain until the power recover; Counter keeps current value when the smart switches between RUN and STOP when C KEEP enable;

**Note:** Only first 31 Counter functions can keep their current value after a loss of power to the smart relay.

## High Speed Counter Function Block

### (1) Counter Mode 7

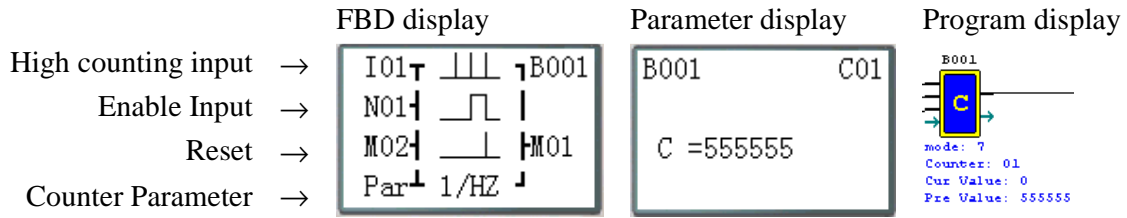

Note: High speed input terminal I01,I02

(2) Counter Mode 8

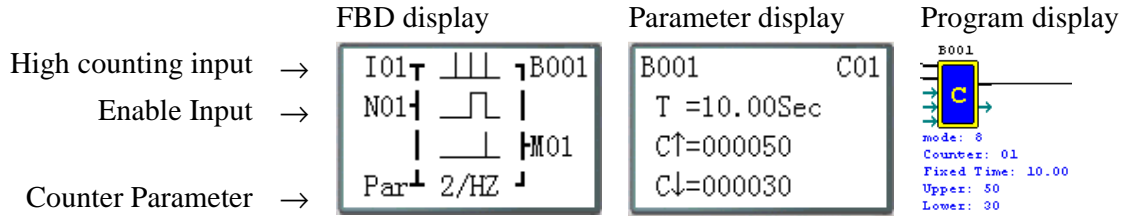

Note: High speed input terminal I01,I02

# RTC Comparator Function Block

(1) RTC Mode 0 (Internal Coil)

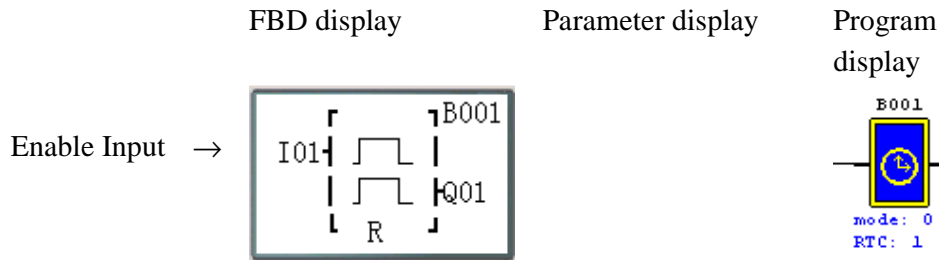

(2) RTC Mode 1 (Daily)

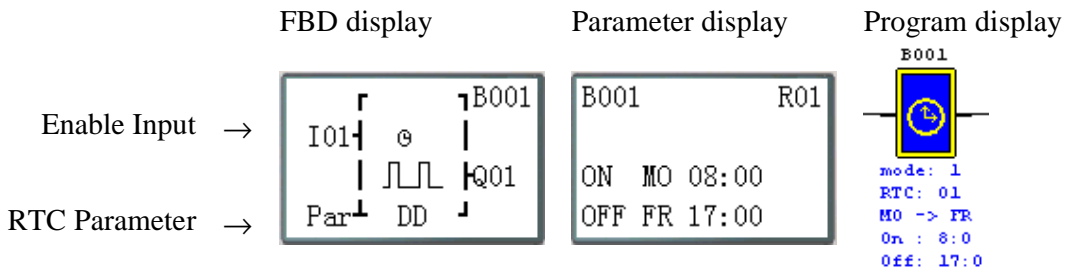

(3) RTC Mode 2 (Continuous)

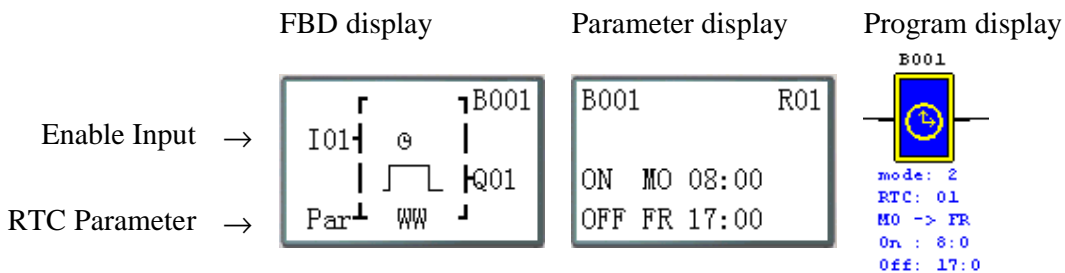

(4) RTC Mode 3 (Year Month Day)

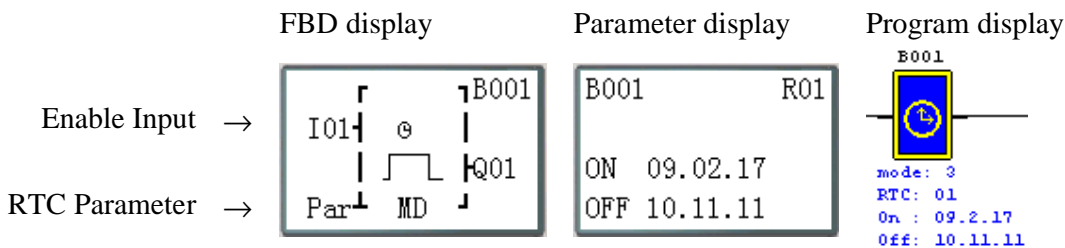

(5) RTC Mode 4 (30-second adjustment)

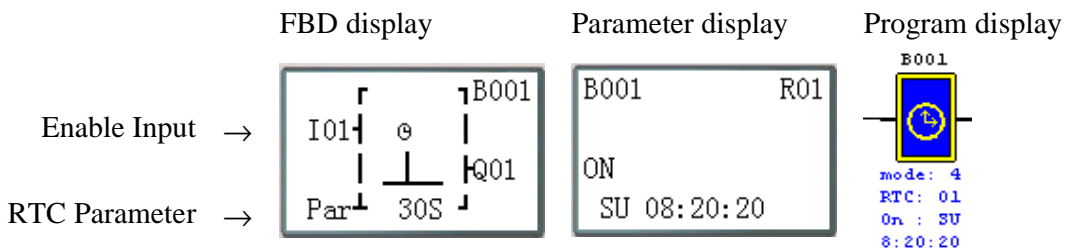

# Analogue Comparator Function Block

## (1) Analogue Comparison Mode 0 (Internal coil)

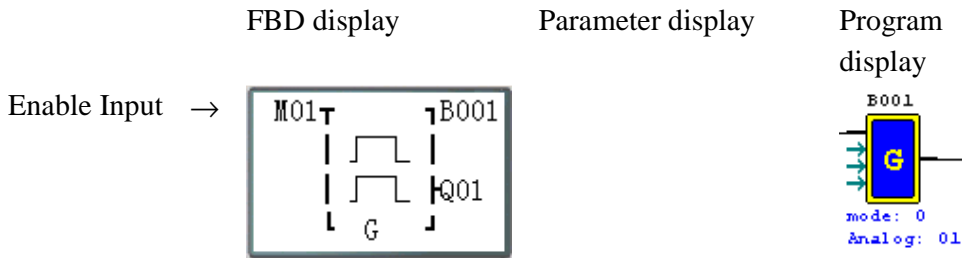

## (2) Analogue Comparison Mode 1

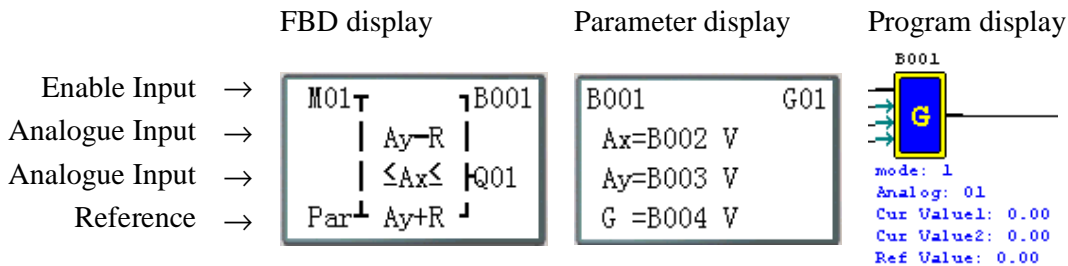

## (3) Analogue Comparison Mode 2

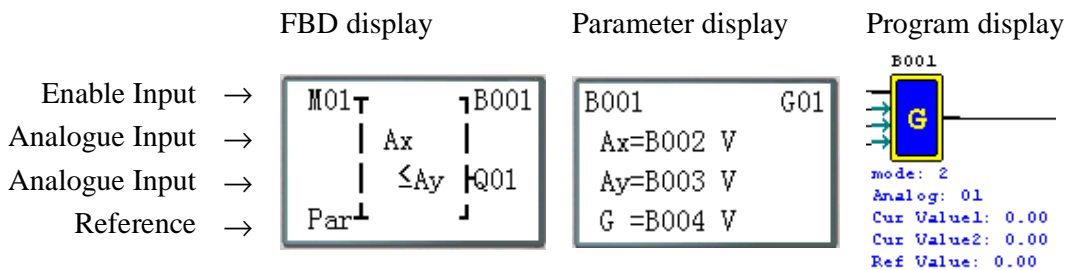

## (4) Analogue Comparison Mode 3

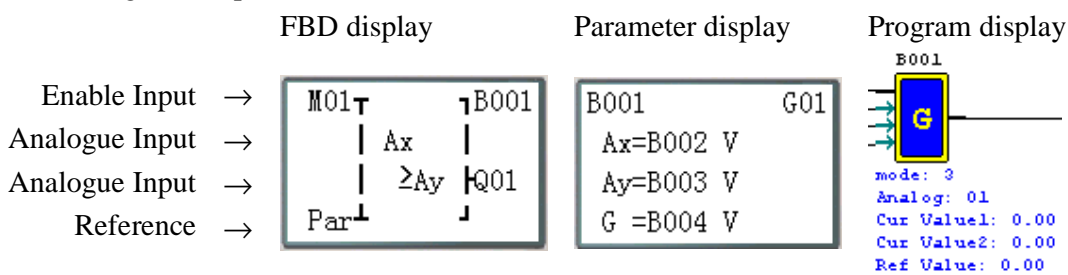

## (5) Analogue Comparison Mode 4

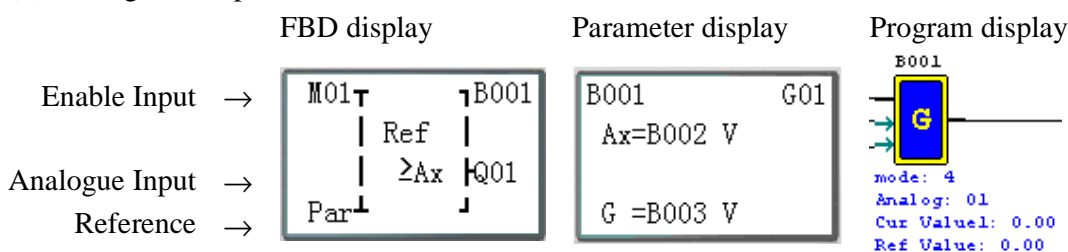

(6) Analogue Comparison Mode 5

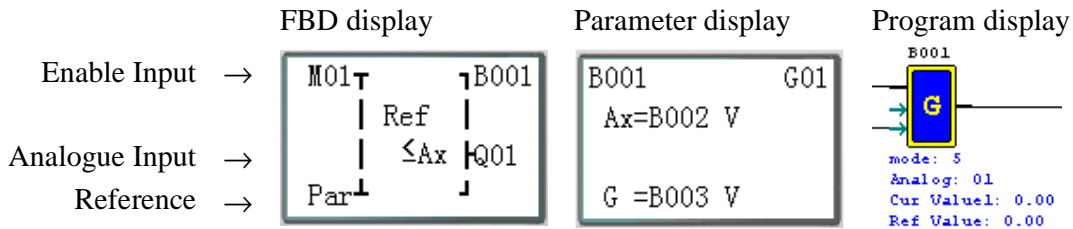

(7) Analogue Comparison Mode 6

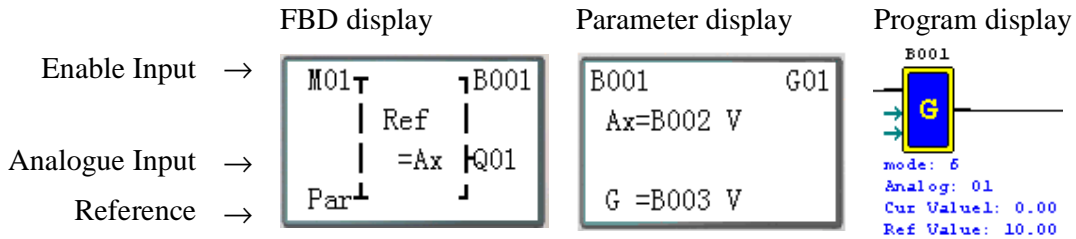

(8) Analogue Comparison Mode 7

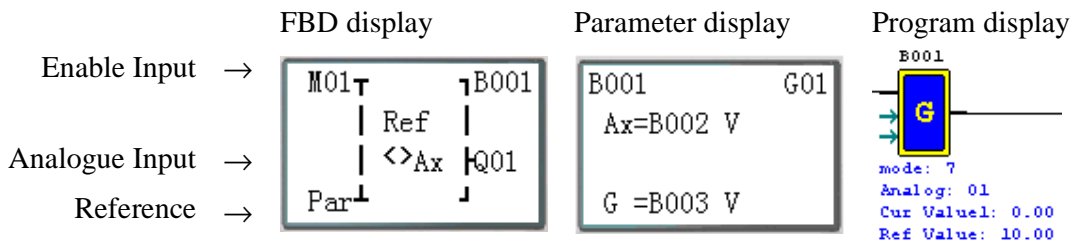

**AS (ADD-SUB) function block**

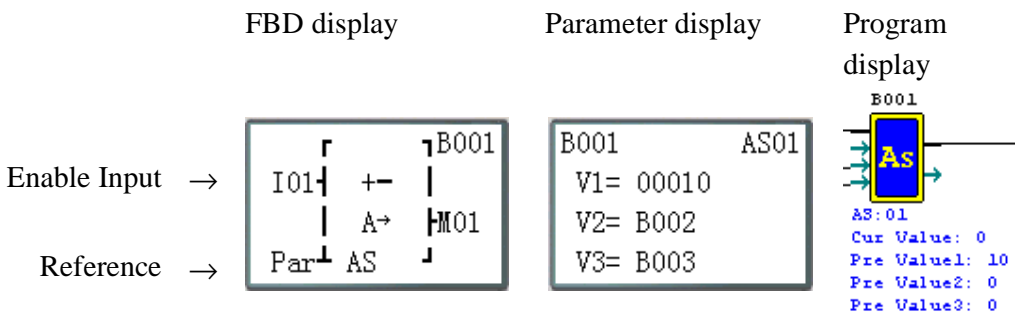

**MD (MUL-DIV) function block**

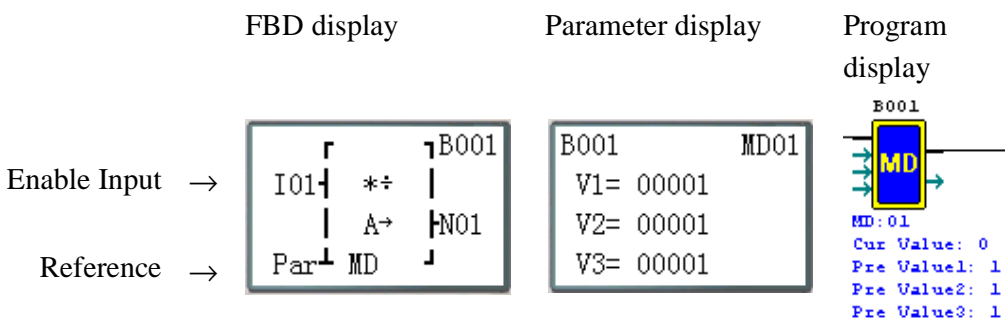

## PID (Proportion- Integral- Differential) function block

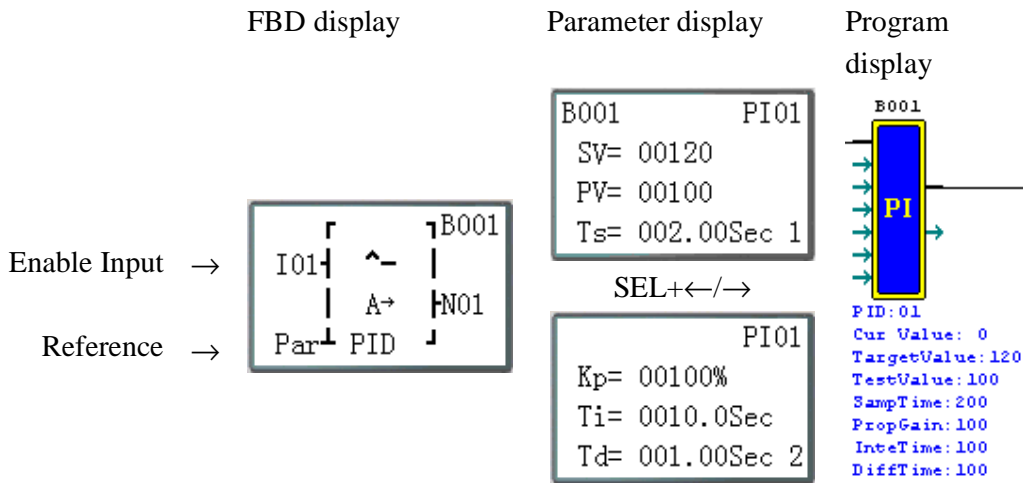

## MX (Multiplexer) function block

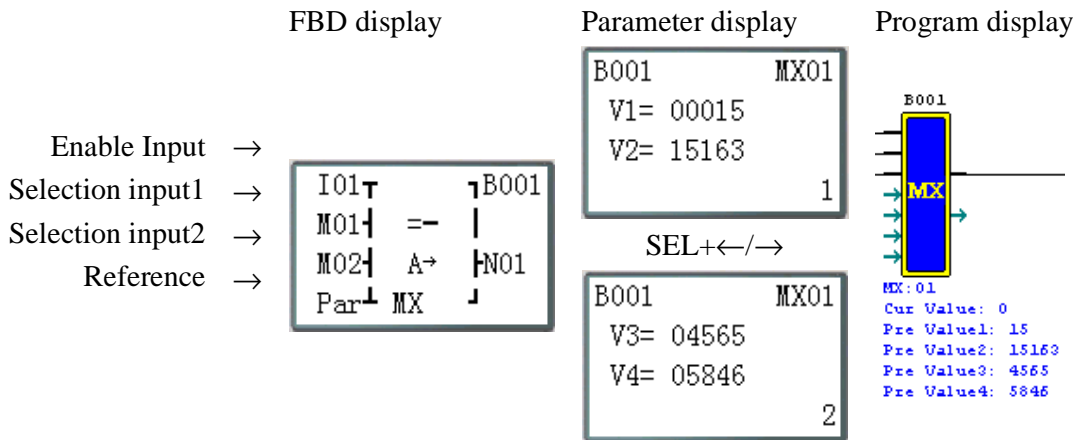

## AR (Analogue-Ramp) function block

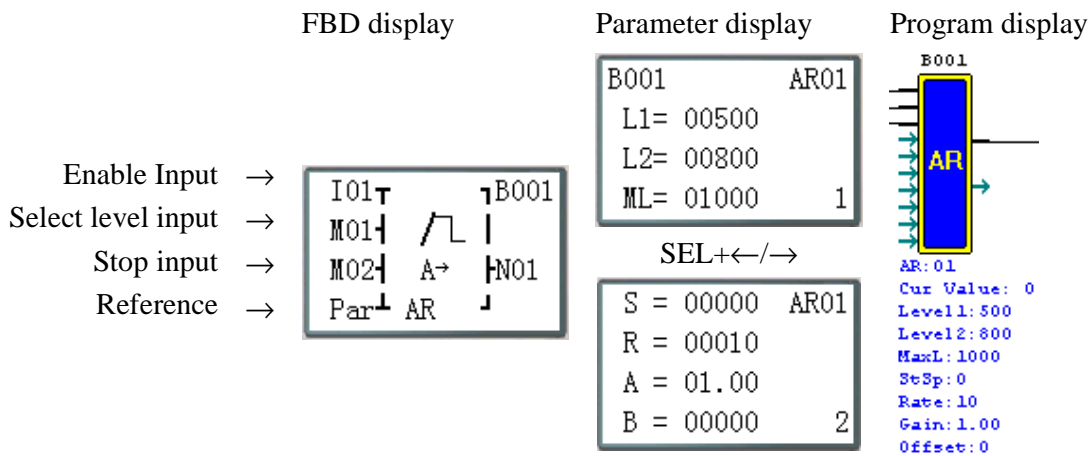

## DR (Data-Register) function block

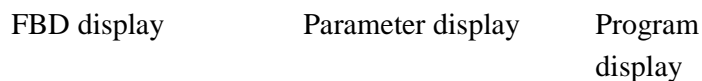



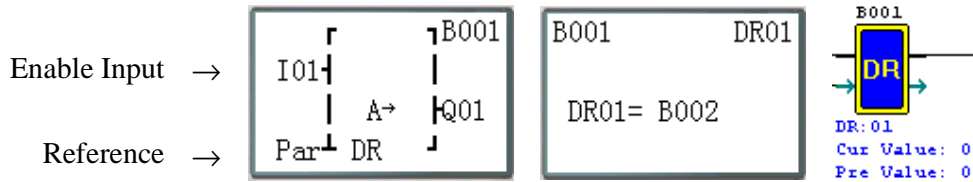

## MU (MODBUS) function block

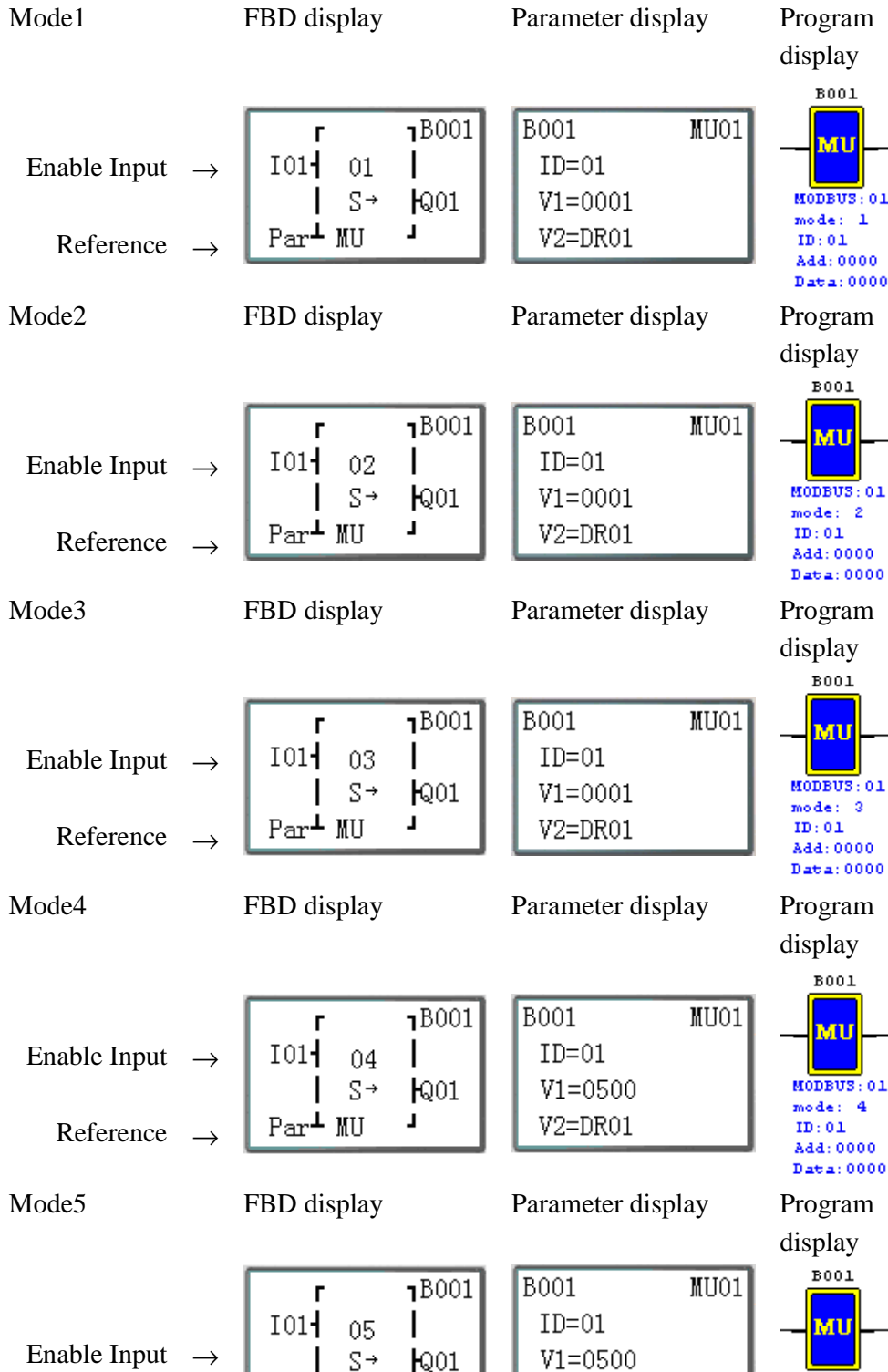

Reference →

## Chapter 6: Hardware Specification

### Normal Specification

Content		Specification
<b>Mode of user program</b>		Ladder & FBD
<b>Environmental</b>	Operation temperature	14° to 140°F (-10° to 60°C)
	Storage temperature	-40° to 158°F (-40° to 70°C)
	Maximum Humidity	90% (Relative, non-condensing)
	Operation Gas	No corrosive gases
<b>Main machine</b>	Maximum Vibration	0.075mm amplitude, 1.0g acceleration according to IEC60068-2-6
	Maximum Concussion	peak value 15g, 11ms according to IEC60068-2-27
<b>Maximum Noise</b>	ESD	Contact ±4KV, air discharge ±8KV
	EFT	Power AC: ±2KV DC: ±1KV
	CS	0.15~80MHz 10V/m
	RS	80~1000MHz 10V/m
	EMI	EN55011 class B
<b>Installation</b>	Enclosure Type	IP20
	Mounting mode	Direct Mounting or DIN-rail (35mm) Mounting
	Direction	According to chapter 2: Installing
<b>Wiring</b>		AWG 14/ψ2.6mm <sup>2</sup>
<b>Size</b>		2×90×59.6 mm(W×L×H) Din rail 72×126×59.6 mm(W×L×H) Direct

## Product Specifications

	AC Models		DC Models		Expansion Units
	10 I/O	20 I/O	12 I/O	20 I/O	
Operating Temperature	-10 to 60 °C				
Storage Temperature	-20 to 70 °C				
Humidity	5 - 90% RH no frost				
Vibration	IEC60068-2-6 (0.075mm Amplitude/1g acceleration)				
Impact Resistance	IEC60068-2-28 (15g peak, 11ms duration)				
Installation	IP20, Direct or Din rail mount (35mm)				
Noise Resistance	ESD:±4KV, air discharge ±8KV, EFT: Power AC:±2KV, DC:±1KV, CS:0.15-80Mhz 10V/m, RS:80-1000Mhz 10V/m, EMI:EN55011 Class B				
Approvals	CE, UL, cUL				
RTC Clock Accuracy	Max 6 minutes/month, 1Farad capacitor for 200Hr run-on after power-down				
Dimensions	72 x 90 x 59.6mm	126 x 90 x 59.6mm	72 x 90 x 59.6mm	126 x 90 x 59.6mm	38 x 90 x 59.6mm
Weight	~230g	~335g	~220g	~345g	~150g
Power Supply	85 - 260Vac, 19.6 - 28.8Vac (24V)		19.6 - 28.8Vdc(24V)10.2 - 13.8Vdc(12V)		Same as Equiv Base Unit
Power Consumption	3.2W	12W	2W	3.1W	1W
Input Threshold	ON: >79Vac, OFF: <40Vac		ON: >15Vdc, OFF: <5Vdc		Same as Equiv Base Unit
Input Current	1.3mA		3.2mA		Same as Equiv Base Unit
Input Impedance	200KΩ		8KΩ		Same as Equiv Base Unit
Input Response Time	50-90ms (240-120Vac)		3.5ms		Same as Equiv Base Unit
Input Max Voltage	260Vac		30Vdc		Same as Equiv Base Unit
High Speed Input (Hz)			1000 (I1), 500/500 (I1/I2)		
Standard Input (Hz)			<40		<40
Max Digital Output Current	Relay: 8A (Resistive), 2A (Inductive)		Relay: 8A(R), 2A(I), Trans: 0.5A(R), 0.2A(I)		Same as Equiv DC model
Min Digital Output Current	16.7mA		0.2mA		Same as Equiv Base Unit
PWM Transistor O/P (Hz)			500 (1ms ON, 1ms OFF)		
Relay Life (no load)	10 Million operations				
Analogue Input Range			0.00 to 9.99V		0.00-9.99V
Analogue Input Resolution			12 bit nominal (0.01V)		12 bit nominal (0.01V)
Analogue Input Impedance			45KΩ		22.5KΩ
RTD Input Range					-100 to 600 °C
RTD Input Resolution					0.1 °C
RTD Excitation Current					0.33mA
Analogue Output Range					0-10V, 4-20mA
Analogue Output Resolution					0.01V, 0.01mA
Program Size	1200 Steps (300 Lines of Ladder), 260 Function Blocks				

Power Specifications

Standard Model Specifications

Model	SMT-EA-R10 SMT-BA-R10		SMT-EA-R20 SMT-BA-R20		SMT-ED-R20 SMT-CD-R20 SMT-CD-T20 SMT-BD-R20		SMT-ED-R12 SMT-BD-R12 SMT-ED-T12	
<b>Power range</b>	AC 100~240V		AC 100~240V		DC 24V		DC 24V	
<b>Voltage Rating</b>	AC 85~265V		AC 85~265V		DC 20.4~28.8V		DC 20.4~28.8V	
<b>Frequency Rating</b>	50 / 60 Hz		50 / 60 Hz					
<b>Frequency range</b>	47~63Hz		47~63Hz					
<b>Instantaneous power down time allowable</b>	10 ms(half cycle) / 20 times (IEC61131-2)		10 ms(half cycle) / 20 times (IEC61131-2)		1ms/10times (IEC61131-2)		10ms/10times (IEC61131-2)	
<b>Fuse</b>	Need connect a fuse or breaker of current 1A		Need connect a fuse or breaker of current 1A		Need connect a fuse or breaker of current 1A		Need connect a fuse or breaker of current 1A	
<b>Isolation</b>	None		None		None		None	
<b>Current average</b>	AC 110V	AC 220V	AC 110V	AC 220V	DC 24V	DC 28.8V	DC 24V	DC 28.8V
	All inputs and relays are ON 90mA	All inputs and relays are ON 90mA	All inputs and relays are ON 100mA	All inputs and relays are ON 100mA	All inputs and relays are ON 145mA	All inputs and relays are ON 185mA	All inputs and relays are ON 115mA	All inputs and relays are ON 125mA
	All inputs and relays are OFF 85mA	All inputs and relays are OFF 85mA	All inputs and relays are OFF 90mA	All inputs and relays are OFF 90mA	All inputs and relays are OFF 80mA	All inputs and relays are OFF 120mA	All inputs and relays are OFF 75mA	All inputs and relays are OFF 85mA
<b>Power Usage</b>	7.5 W		12.5 W		5 W		4.5W	

## 12V DC Model Specifications

Model	SMT-ED12-R12		SMT-ED12-R20	
Voltage Rating	DC 12 V		DC 12 V	
Operation Power range	DC 10.4~14.4 V		DC 10.4~14.4 V	
Instantaneous power down time allowable	10 ms / 10 times (IEC 61131-2)		1ms/ 10 times (IEC 61131-2)	
Fuse	Need connect a fuse or breaker of Current 1A		Need connect a fuse or breaker of current 1A	
Isolation	None		None	
Current average	DC 12V	DC 14.4V	DC 12V	DC 14.4V
	All inputs and relays are ON 195mA	All inputs and relays are ON 195mA	All inputs and relays are ON 265mA	All inputs and relays are ON 265mA
	All inputs and Relays are OFF 160mA	All inputs and Relays are OFF 160mA	All inputs and Relays are OFF 200mA	All inputs and Relays are OFF 200mA
Consume power	2.5W		3.5 W	

## 24V AC model Specifications

Model	SMT-EA24-R10		SMT-EA24-R20	
Voltage Rating	AC 24V		AC 24V	
operation Power range	20.4~28.8V AC		20.4~28.8V AC	
instantaneous power down time allowable	10 ms(half cycle) / 20 times		10 ms(half cycle) / 20 times	
fuse	Need connect a fuse or breaker of Current 1A		Need connect a fuse or breaker of current 1A	
Isolation	None		None	
Current average	AC 24V	AC 28.8V	AC 24V	AC 28.8V
	All inputs and relays are ON 270mA	All inputs and relays are ON 250mA	All inputs and relays are ON 290mA	All inputs and relays are ON 260mA
	All inputs and Relays are OFF 160mA	All inputs and Relays are OFF 160mA	All inputs and Relays are OFF 200mA	All inputs and Relays are OFF 200mA
Power Usage	6.5W		7 W	

## Power circuitry diagram

- 1) AC 10/20 points

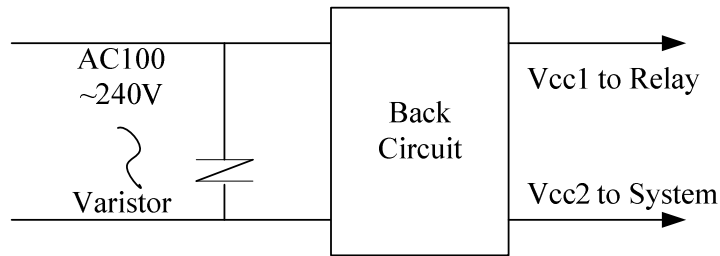

- 2) DC 12V, DC 24V

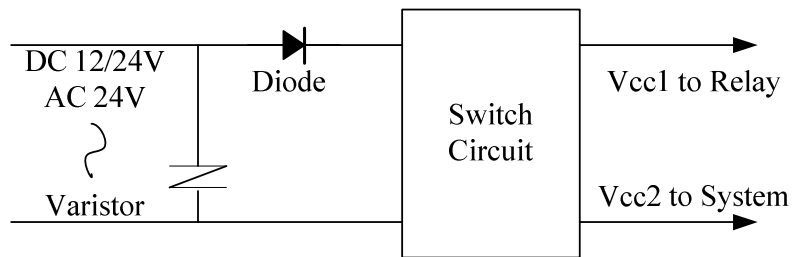

- 3) Mainframe, expansion and communication

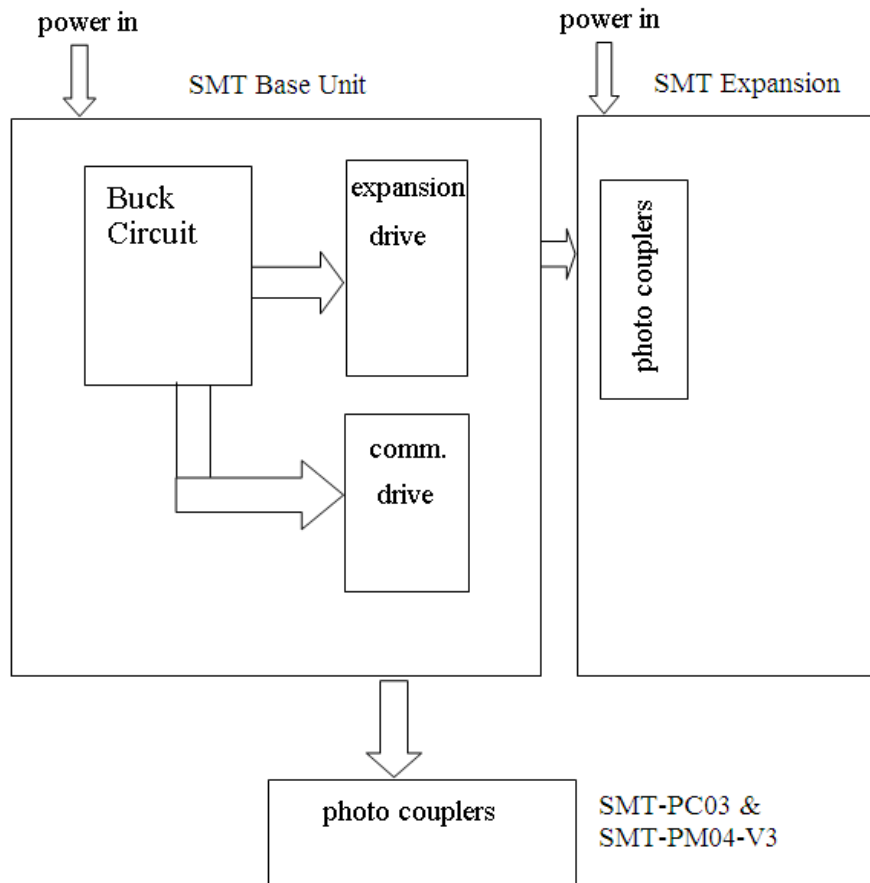

## Input Specifications

### 100~240V AC model

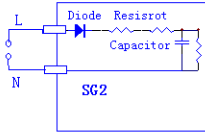
Model	SMT-EA-R10 SMT-BA-R10		SMT-EA-R20 SMT-BA-R20	
Input circuitry				
number	6(digital input)		12(digital input)	
Signal current input	AC 110V 0.66 mA	AC 220V 1.3 mA	AC 110V 0.55mA	AC 220V 1.2 mA
ON current input	> AC 79 V / 0.41mA		> AC 79 V / 0.4mA	
OFF current input	< AC 40 V / 0.28 mA		< AC 40 V / 0.15mA	
Wire length	< / = 100 m		< / = 100 m	
Response time of input	On=>Off		On=>Off	
	Typical 50/60 Hz 50/45 ms(AC 110 V)		Typical 50/60 Hz 50/45 ms(AC 110 V)	
	Typical 50/60 Hz 90/85 ms(AC 220 V)		Typical 50/60 Hz 90/85 ms(AC 220 V)	
	Off=>On		Off=>On	
	Typical 50/60 Hz 50/45 ms(AC 110 V)		Typical 50/60 Hz 50/45 ms(AC 110 V)	
	Typical 50/60 Hz 22/18 ms(AC 220 V)		Typical 50/60 Hz 22/18 ms(AC 220 V)	

### 24V AC model

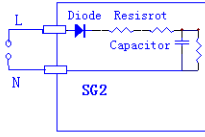
Model	SMT-EA24-R10		SMT-EA24-R20	
Input circuitry				
Number	6(digital input)		12(digital input)	
Signal current input	3 mA		3mA	
ON current input	> AC 14 V / 3mA		> AC 14 V / 3mA	
OFF current input	< AC 6 V / 0.85 mA		< AC 6 V / 0.85mA	
Wire length	< / = 100 m		< / = 100 m	
Response time of input	On=>Off		On=>Off	
	Typical 50/60 Hz 90/90ms		Typical 50/60 Hz 90/90ms	
	Off=>On		Off=>On	
	Typical 50/60 Hz 90/90ms		Typical 50/60 Hz 90/90ms	

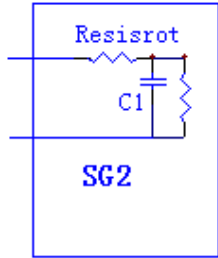
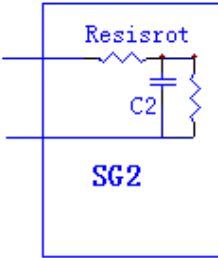
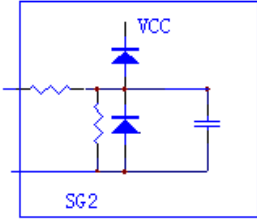

## 24V DC, 12I/O model

Model	SMT-ED-R12 & SMT-ED-T12			
	Normal digital input	High speed input	Analogue input used as normal digital input	Analogue input
Input circuitry	I03~I06 	I01,I02 	I07,I08 	
Number	4	2	2	2
Signal current input	3.2mA/24V DC	3.2mA/24V DC	0.63mA/24V	<0.17 mA/10V
ON current input	>1.875mA/15V	>1.875mA/15V	>0.161mA/9.8V	
OFF current input	< 0.625mA/5V	< 0.625mA/5V	< 0.085mA/5V	
Wire length	< / = 100 m	< / = 100 m	< / = 100 m	< / = 30 m(shield wire)
Response time of input	On=>Off	On=>Off	On=>Off	
	3ms	0.3ms	Typical: 5ms	
Response time of input	Off=>On	Off=>On	Off=>On	
	5ms	0.5ms	Typical: 3ms	
Input voltage				0~10 V DC
Precision class				0.01V DC
Bit of conversion				10
Error				±2%±0.12V
Conversion time				1 cycle
Sensor resistance				<1K ohm

## 24V DC, 20I/O model

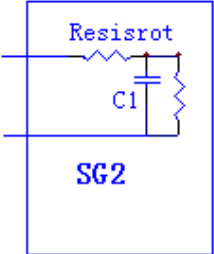
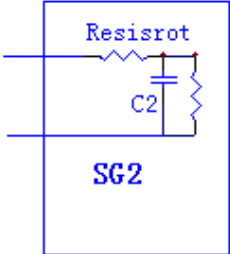
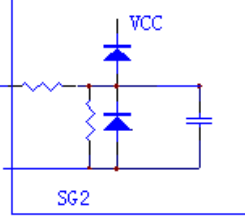
Model	SMT-ED-R20 & SMT-CD-R20 & SMT-CD-T20			
	Normal digital input	High speed input	Analogue input used as normal digital input	Analogue input
Input circuitry	I03~I08 	I01,I02 	I09,I0A,I0B,I0C 	
Number	6	2	4	4
Signal current input	3.1mA/24V DC	3.1mA/24V DC	0.63mA/24V	<0.17 mA/10V
ON current input	>1.875mA/15V	>1.875mA/15V	>0.163mA/9.8V	
OFF current input	< 0.625mA/5V	< 0.625mA/5V	< 0.083mA/5V	
Wire length	< / = 100 m	< / = 100 m	< / = 100 m	< / = 30 m(shield wire)
Response time of input	On=>Off	On=>Off	On=>Off	
	5ms	0.5ms	Typical: 5ms	
Response time of input	Off=>On	Off=>On	Off=>On	
	3ms	0.3ms	Typical: 3ms	
Input voltage				0~10 V DC
Precision class				0.01V DC
Bit of conversion error				8
Conversion error				±2%±0.12V
Conversion time				1 cycle
Sensor resistance				<1K ohm

## Output Specifications

Model	Relay	Transistor
<b>Output circuitry</b>		
<b>Extern power</b>	Less than AC265, DC30V	23.9~24.1V
<b>Circuitry isolation</b>	mechanism isolation	Photo couplers isolation
<b>Maximal Load</b>	<b>Resistive</b>	8A/point
	<b>Inductive</b>	—
	<b>Light</b>	200W
<b>Open drain current</b>	—	<10uA
<b>Minimum Load</b>	—	—
<b>Response time</b>	<b>OFF→ON</b>	15 ms
	<b>ON→OFF</b>	15 ms
		25 us
		Less than 0.6 ms

### Output Port wiring notice

### Light Load

The current value will be 10~20 times the normal rated value for several milliseconds when the filament is first powered. A distributed resistance or current choke should be added to the circuit to reduce the in-rush current level.

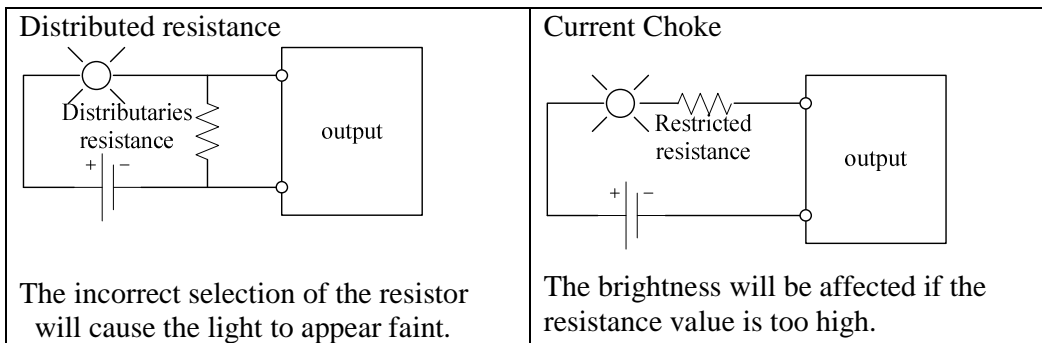

## Inductance Load

There will be a voltage spike(KV) when the inductance loads switch between ON and OFF states, particularly with relay outputs. The methods for absorbing this voltage spike are shown below.

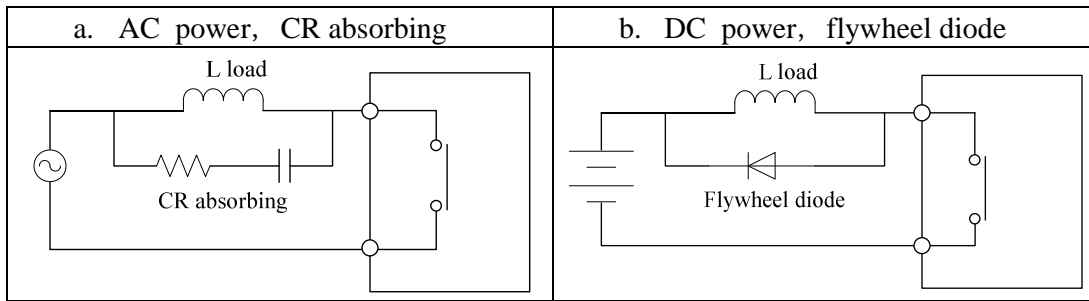

Please do can't use capacitance alone as absorbing as shown below.

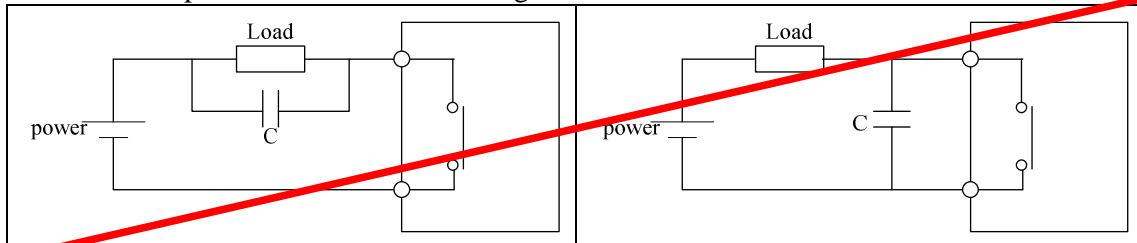

## Life of relay

Life Expectancy

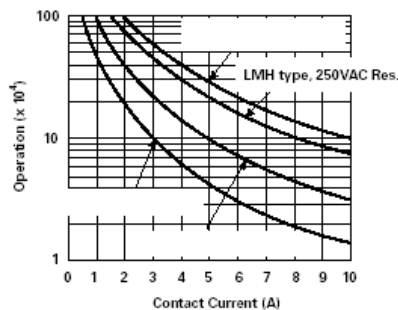

- ✘ The data of picture above is standard, but the life of relay is influenced by the temperature of operation environmental.
- ✘ The life is more than 100K times if the current is less than 2A.

### Power mode

Mode	Input/Output
DC +12V	AC 100~240V / DC +12V
DC +24V	AC 100~240V / DC +24V

### Accessory

MODE	Description
PM04(3rd)	memory cartridge
SMT Client	SMT program software

**Dimensions of SMT**  
10/12 points

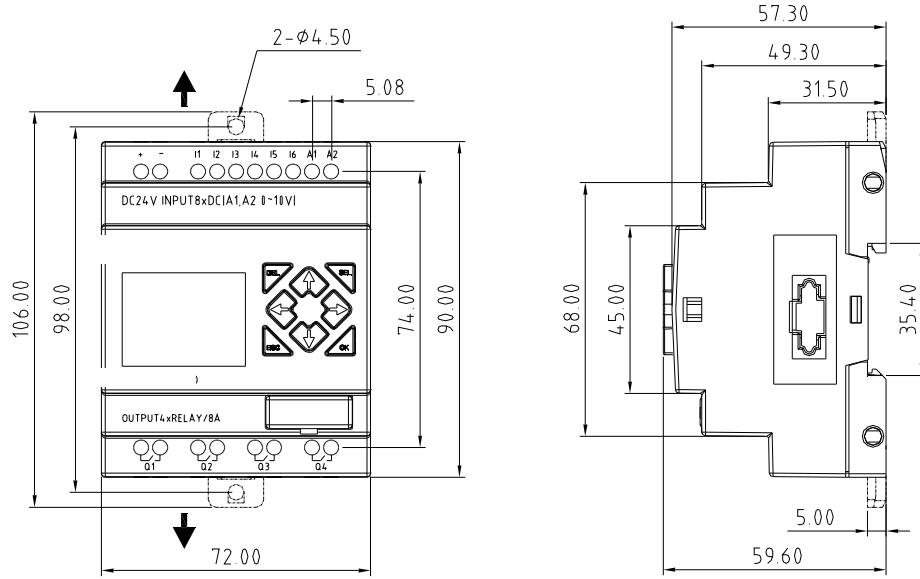

20 points

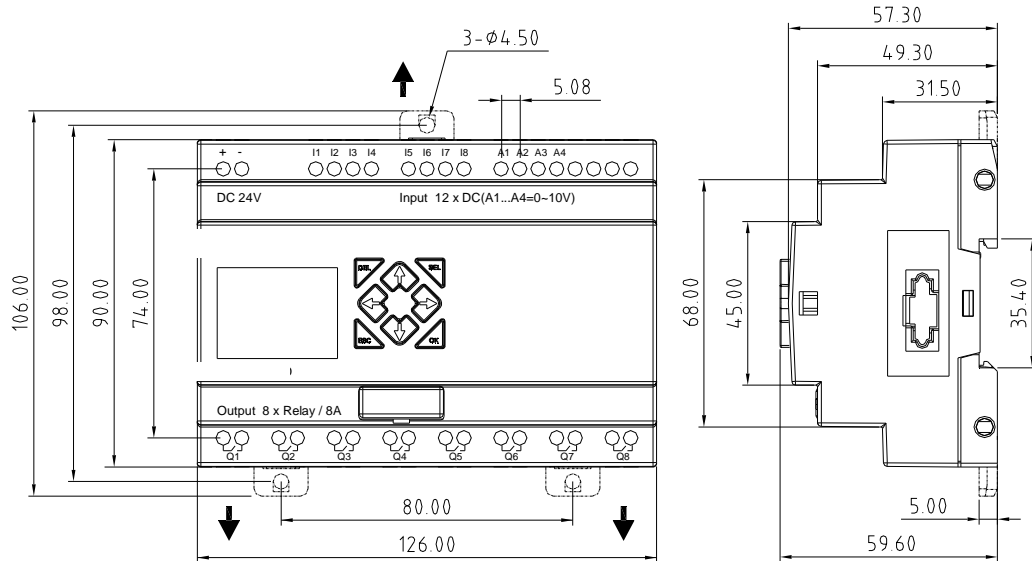

## Chapter 7: 20 Points C type Models Instruction

Only SMT-CD-R20, SMT-CD-T20, SMT-CD12-R20 have special comms functions. The settings take effect only after power up.

### Function Summary:

Communication parameter	Communication mode parameter and baud rate.
Remote IO function	It can be used to communication between 2 SMT units. For more information you could refer to Chapter 4: Remote IO.
I/O Link function	Up to 8 additional CD type SMT units can be configured as I/O Link nodes. Each SMT can make used of the I/O information of other SMT for detail, please refer to Chapter 4: Data Link.
Modbus RTU master	SMT can be used as a Modbus master
Modbus communication	SMT can be controlled by computer or other controller with Modbus protocol via RS 485 port.

### Detail instruction

#### Communication parameter

##### 1. About SMT communication parameter

SMT provides different communication parameter to satisfy your needs. And there are two ways to set that parameter.

- . Setting communication parameter via SMT Client.
  - i. Insert the plastic connector end of the programming cable into the ISmart relay. Connect the opposite end of the cable to an RS232 serial port on the computer.
  - ii. In SMT Client Software Select **Operation>>Module System Set**, to open the dialog box as show below.

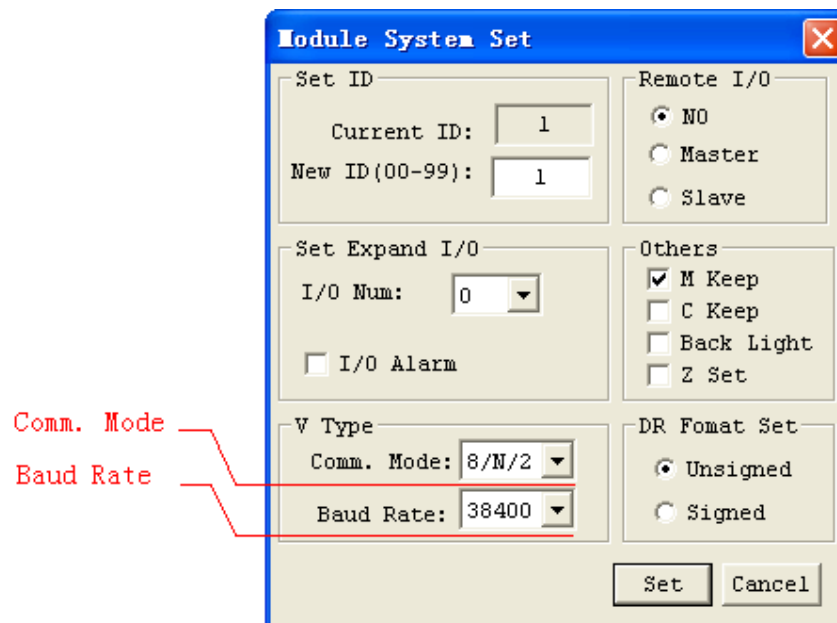

- iii. As the illustration show, you can set Communication Mode and Baud Rate.
- iv. In the table below, list the options which you can choose from.

Comm. Mode	8/N/2 Data 8bit, No Parity, 2 Stop bit.
	8/E/1 Data 8bit, Even Parity, 1 Stop bit.
	8/O/1 Data 8bit, Odd Parity, 1 Stop bit.
	8/N/1 Data 8bit, No Parity, 1 Stop bit.
Baud Rate.	4800 bps 9600 bps 19200 bps 38400 bps 57600 bps 115200 bps

- . Set communication format and Baud Rate on SMT.
  - i. Press ESC to enter main menu.
  - ii. Press UP/DOWN to choose SET menu, and press OK to enter it.
  - iii. Press UP/DOWN makes the LCD to display the options as show below.

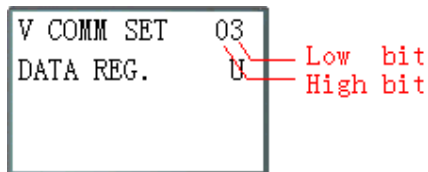

- iv. Changing high bit would set Comm. Mode; changing low bit would set Baud Rate.

Content	Data	meaning
<b>High bit</b>	0	8/N/2 Data 8bit, No Parity, 2 Stop bit.
	1	8/E/1 Data 8bit, Even Parity, 1 Stop bit.
	2	8/O/1 Data 8bit, Odd Parity, 1 Stop bit.
	3	8/N/1 Data 8bit, No Parity, 1 Stop bit.
<b>Low bit</b>	0	4800 bps
	1	9600 bps
	2	19200 bps
	3	38400 bps
	4	57600 bps
	5	115200 bps

2. SMT RS485 port default communication parameter as table show below:

<b>Baud rate</b>	38400bps
<b>Data bit</b>	8
<b>Stop bit</b>	2
<b>Parity</b>	No
<b>Frame length maximum</b>	128 bytes

- ※ SMT V2 RS485 port communication parameter as table show above.
- ※ The communication parameter setting takes effect after power up again.

## Remote IO function

Function Description:

Up to 2 additional SMT units can be configured as Remote I/O nodes, and linked to one master smart relay.

The Master can run its programming, but the Slave can't. The Master writes its state of expansion output coil Y to Slaver's output coil Q. The Slaver writes its state of input coil I to Master's expansion input coil X.

I/O Address	Master	Slave
<b>Input Coils</b>	I01~I0C	
<b>Output Coils</b>	Q01~Q08	
<b>Expansion Input Coils</b>	X01~X0C	I01~I0C
<b>Expansion Output Coils</b>	Y01~Y0C	Q01~Q08

Hardware Configuration:

1. Link 2 CD type SMT as illustration show below.
2. Set left SMT in the illustration to master.
3. Set the other SMT to Slave.

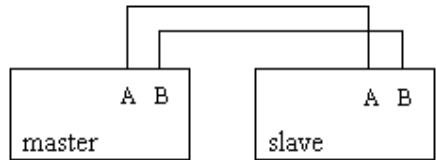

Example:

Create a Ladder program as show below in SMT which is master.

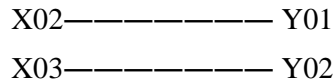

If input coils I02 and I03 in the Slave are ON; X02 and X03 in master will be on. Y01 and Y02 in the master will be ON when Q1 and Q2 in the slave are ON. You can see this in the IO interface show below:

I/O State on Slave Run mode	I/O State on Master Run mode
I.1 2 3 4 5 6 7 8 9 0 A B C	X. 1 2 3 4 5 6 7 8 9 0 A B C
Z.1 2 3 4	Y. 1 2 3 4 5 6 7 8 9 0 A B C
Q.1 2 3 4 5 6 7 8 9 0 A B C	EXE
MO 14 : 42	2010.05.09



## IO Link Function

Hardware Configuration:

1. Link not more 8 V type SMT as show below.
2. Set all the SMT in SET menu to No Remote IO.
3. Set those SMT's ID continuously 00 ,01,02,... The max number of the ID is 07.

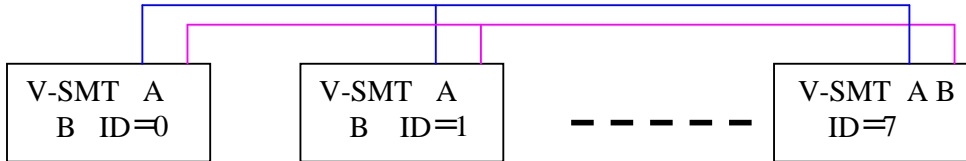

Example:

1. Link 8 20 pointe V type SMT according to the steps of the Hardware Configuration.
2. Create a ladder program as show below in those 8 SMT.

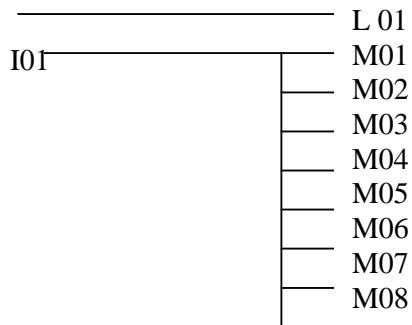

3. Set L1 of the SMT which's ID =7 as fellow illustration.

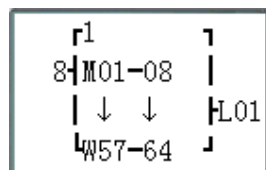

4. L1 of other 7 SMT be set as fellow illustration.

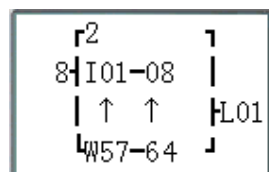

5. Run program. Let I01 of the SMT which is ID = 7 on. And M01~M08 will be on state.

6. You will find M01~M08 of other 7 SMT will be controlled by the M01~M08 of the SMT which's ID=7.

## Modbus RTU master

MODBUS function carries out Modbus RTU master communication at RS485 port. There are 15 MODBUS functions: MU01~MU0F. Remote IO and Date Link are precedence than MODBUS. MODBUS is executed when the system setting is N Remote IO and ID isn't 0.

MODBUS comes into possession of communication port, release the port when disable and one MODBUS period is completed. There can be a number of communication orders in one program, but only one order can come into possession of communication port at the same time. And the others keep their enable state for executing function.

Function mode corresponding communication function code:

mode	Communication function code
1	03 (read register)
2	06 (write single register)
3	10 (write some registers)
4	01 (read coil)
5	05 (write single coil)

The coil used in MODBUS function:

Received (M3D)	M3D is set to ON after received, then check-up for error. Transferring data to target address if there is no error.
Error flag (M3E)	communication error flag
Time out flag (M3F)	M3F is set to 1 when the time from after sending to start receiving is longer than setting, and M3D also be set to 1. M3F is automatically reset if M3D reset.

The time out time is depending communication baud rate as shown in the table below:



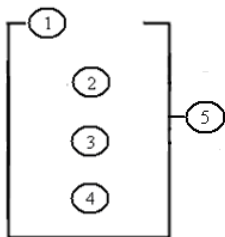

Baud rate (bps)	Time (ms)
4800、9600、19200、38400	125
57600	100
115200	80



There are 5 parameters in MODBUS function as shown below.

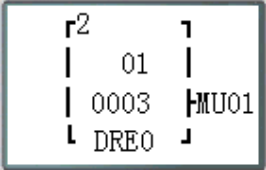
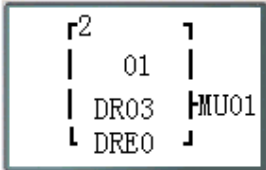

Symbol	Description
①	MODBUS mode (1~5)
②	Communication address: slave ID, range: 0~127
③	Communication content: address and data length: 1) address is constant, range: 0000~ffff; length must be 1 word ; 2) DR code, get address and length from this DR and the next
④	DR code, store sending/receiving data from this DR
⑤	MODBUS code (MU01~MU0F)

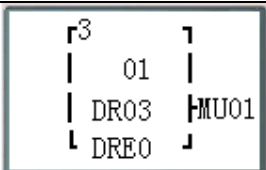
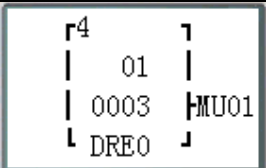
Examples:

Mode	Display		
1 Read register		Address is constant: 0003, Length = 1, Send: 01 03 00 03 00 01 CRC16;	Receive: 01 03 02 data1 data2 CRC16, data storage: DRE0= (data1<<8)   data2,
		Address is DR03=0001, Length is DR04=0002, Send: 01 03 00 01 00 02 CRC16;	Receive: 01 03 04 data1 data2 data3 data4 CRC16, data storage: DRE0= (data1<<8)   data2, DRE1= (data3<<8)   data4
2 Write single register		Address is constant: 0003, Length = 1, data storage: DRE0=1234(hex: 04D2), Send: 01 06 00 03 04 D2 CRC16;	Receive: 01 06 00 03 04 D2 CRC16;
		Address: DR03=0001, data storage: DRE0=1234(hex: 04D2), Send: 01 06 00 01 04 D2 CRC16;	Receive: 01 06 00 01 04 D2 CRC16;
3 Write register		Address: 0003, Length = 1, data storage: DRE0=1234(hex: 04D2), Send: 01 10 00 03 00 01 02 04 D2 CRC16;	Receive: 01 10 00 03 00 01 CRC16;
		Address: DR03=0001, Length: DR04=0002, data storage: DRE0=1234(hex: 04D2), DRE1=5678(hex: 162E), Send: 01 10 00 01 00 02 04 04 D2 16 2E CRC16;	Receive: 01 10 00 01 00 02 CRC16;
4 Read coil		Address: 0003, Length = 10H, Send: 01 01 00 03 00 10 CRC16;	Receive: 01 01 02 data1 data2 CRC16, data storage: DRE0= (data1<<8)

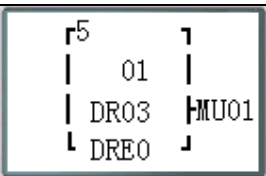
		Address: DR03=0001, Length: DR04=0016, Send: 01 01 00 01 00 10 CRC16; Max value in DR04 is 400.	data2; Receive: 01 01 02 data1 data2 CRC16, data storage: DRE0= (data1<<8)   data2;
5 Write single coil		Address: 0003, data storage: DRE0=65280(hex: FF00), Send: 01 05 00 03 FF 00 CRC16;	Receive: 01 05 00 03 FF 00 CRC16;
		Address: DR03=0001, data storage: DRE0=65280(hex: FF00), Send: 01 05 00 01 FF 00 CRC16;	Receive: 01 05 00 01 FF 00 CRC16;

### Slave via Modbus RTU Protocol

#### Function Description:

SMT series PLC can be communication controlled by the computer or other controller with the communication. PC and other controller can read and write IO state, Function Block preset value. It also can use to read Function Block current value, control SG Run/Stop mode.

#### Hardware Configuration:

1. Line some SMT RS485 port A, B as show below.
2. Set all the SMT in the SET menu to No Remote IO.
3. Set SMT ID = 01~99, each of those SMT's ID is different.

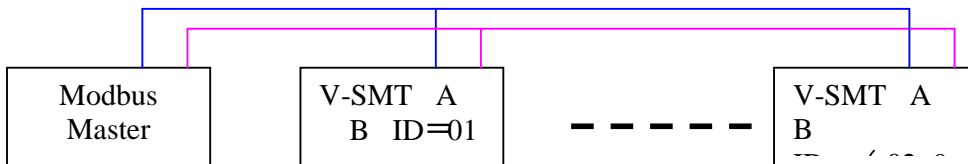

**SMT Modbus protocol**

If SMT receive a correct frame, it will carry out the command, it responses a correct frame to computer or other controller. If the command that SMT received is not allowed, SMT responses Exception code to computer or controller.

- Command format and Response format

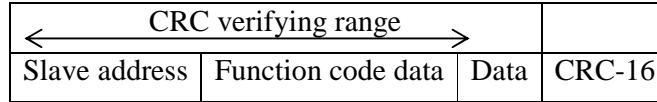

- The Response command format, once SMT receive an unexpected command.

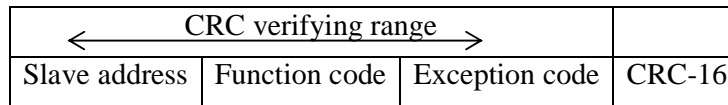

Command Format:

Slave address	Function code		Data	CRC-16	Exception code
00H: broadcast to all the drivers	01H	Read coils status	For detail please refer register address	CRC verifying range contain Slave Address Function Code Exception Code	For detail, please refer Exception Code Instruction
01H: to the No.01 driver	05H	Write single coil			
0FH: to the No.15 driver	03H	Read registers			
10H: to the No.16 driver	06H	Write single register			
....	10H	Write multiple registers			
63H: to the No.99 driver	08H	diagnostic			

Exception Code:

Under communication linking, the controller responses the Exception Code and send Function Code add 80H to main system if there is error happened.

Exception Code	Description
51	Frame error (Function Code error, Register Encoding error, Data Quantity Error)
52	Run mode and command disable
53	Secret mode and command disable
54	Data value over rang
55	SMT system ROM error
56	SMT RTC not exist, can't operate RTC
57	SMT the other error
58	Commands do not match SMT edit mode
59	Brand ID error

# Useful Modbus References

Modbus Address (i3) add1	Modbus Address (XGB)	Usable Comm.	Content – Bits of 16 bit WORD																
			F	E	D	C	B	A	9	8	7	6	5	4	3	2	1	0	
41537	41536	Read/Write	R10	R0F	R0E	R0D	R0C	R0B	R0A	R09	R08	R07	R06	R05	R04	R03	R02	R01	
41538	41537		-	R1F	R1E	R1D	R1C	R1B	R1A	R19	R18	R17	R16	R15	R14	R13	R12	R11	
41539	41538		G10	G0F	G0E	G0D	G0C	G0B	G0A	G09	G08	G07	G06	G05	G04	G03	G02	G01	
41540	41539		-	G1F	G1E	G1D	G1C	G1B	G1A	G19	G18	G17	G16	G15	G14	G13	G12	G11	
41541	41540		T10	T0F	T0E	T0D	T0C	T0B	T0A	T09	T08	T07	T06	T05	T04	T03	T02	T01	
41542	41541		-	T1F	T1E	T1D	T1C	T1B	T1A	T19	T18	T17	T16	T15	T14	T13	T12	T11	
41543	41542		C10	C0F	C0E	C0D	C0C	C0B	C0A	C09	C08	C07	C06	C05	C04	C03	C02	C01	
41544	41543		-	C1F	C1E	C1D	C1C	C1B	C1A	C19	C18	C17	C16	C15	C14	C13	C12	C11	
41545	41544		M10	M0F	M0E	M0D	M0C	M0B	M0A	M09	M08	M07	M06	M05	M04	M03	M02	M01	
41546	41545		M20	M1F	M1E	M1D	M1C	M1B	M1A	M19	M18	M17	M16	M15	M14	M13	M12	M11	
41547	41546		M30	M2F	M2E	M2D	M2C	M2B	M2A	M29	M28	M27	M26	M25	M24	M23	M22	M21	
41548	41547		-	M3F	M3E	M3D	M3C	M3B	M3A	M39	M38	M37	M36	M35	M34	M33	M32	M31	
41549	41548		N10	N0F	N0E	N0D	N0C	N0B	N0A	N09	N08	N07	N06	N05	N04	N03	N02	N01	
41550	41549		N20	N1F	N1E	N1D	N1C	N1B	N1A	N19	N18	N17	N16	N15	N14	N13	N12	N11	
41551	41550		N30	N2F	N2E	N2D	N2C	N2B	N2A	N29	N28	N27	N26	N25	N24	N23	N22	N21	
41552	41551		-	N3F	N3E	N3D	N3C	N3B	N3A	N39	N38	N37	N36	N35	N34	N33	N32	N31	
41553	41552		-	-	-	-	I0C	I0B	I0A	I09	I08	I07	I06	I05	I04	I03	I02	I01	
41554	41553		-	-	-	-	X0C	X0B	X0A	X09	X08	X07	X06	X05	X04	X03	X02	X01	
41555	41554		-	-	-	-	Y0C	Y0B	Y0A	Y09	Y08	Y07	Y06	Y05	Y04	Y03	Y02	Y01	
41556	41555		-	-	-	-	-	-	-	-	Q08	Q07	Q06	Q05	Q04	Q03	Q02	Q01	
41557	41556		-	-	-	-	-	-	-	-	-	-	-	-	Z04	Z03	Z02	Z01	
41558	41557		H10	H0F	H0E	H0D	H0C	H0B	H0A	H09	H08	H07	H06	H05	H04	H03	H02	H01	
41559	41558		-	H1F	H1E	H1D	H1C	H1B	H1A	H19	H18	H17	H16	H15	H14	H13	H12	H11	
41560	41559		-	-	-	-	-	-	-	-	L08	L07	L06	L05	L04	L03	L02	L01	
41561	41560		-	-	-	-	-	-	-	-	-	-	-	-	-	S01	P02	P01	
41562	41561		W10	W0F	W0E	W0D	W0C	W0B	W0A	W09	W08	W07	W06	W05	W04	W03	W02	W01	
41563	41562		W20	W1F	W1E	W1D	W1C	W1B	W1A	W19	W18	W17	W16	W15	W14	W13	W12	W11	
41564	41563		W30	W2F	W2E	W2D	W2C	W2B	W2A	W29	W28	W27	W26	W25	W24	W23	W22	W21	
41565	41564	W40	W3F	W3E	W3D	W3C	W3B	W3A	W39	W38	W37	W36	W35	W34	W33	W32	W31		
41569	41568	Read (Only FBD)	B16	B15	B14	B13	B12	B11	B10	B09	B08	B07	B06	B05	B04	B03	B02	B01	
41570	41569		B32																B17
41571	41570		B48																B33
41572	41571		B64																B49
41573	41572		B80																B65
41574	41573	Read (Only FBD)	B96															B81	
41575	41574		B112																B97
41576	41575		B128																B113
41577	41576		B144																B129
41578	41577		B160																B145
41579	41578		B176																B161
41580	41579		B192																B177
41581	41580		B208																B193
41582	41581		B242																B209
41583	41582		B240																B243
41584	41583		B256																B241
41585	41584		-	-	-	-	-	-	-	-	-	-	-	-	B260	B259	B258	B257	

42833	42832	Read	A1_VALUE	Scale:
-------	-------	------	----------	--------

42834	42833		A2_VALUE	0000~0999
42835	42834		A3_VALUE	
42836	42835		A4_VALUE	
42837	42836		A5_VALUE	
42838	42837		A6_VALUE	
42839	42838		A7_VALUE	
42840	42839		A8_VALUE	
42865	42864	Read	AT01	
42866	42865		AT02	
42867	42866		AT03	
42868	42867		AT04	
42881	42880	Read	AQ01	Scale: Voltage mode: 0~1000 Current mode: 0~500
42882	42881		AQ02	
42883	42882		AQ03	
42884	42883		AQ04	

Get more protocol information from form 'SMT-V3 Modbus protocol.pdf'



## Chapter 8: Expansion Module

### Summary:

Digital Input/Output module: SMT-8ER-A, SMT-8ER-D, SMT-8ET-D, SMT-8ER-24A

Analogue Input module: SMT-4PT, SMT-4AI

Analogue Output module: SMT-2AO

Communication module: MODBUS, DNET, PBUS, TCP/IP

SMT C type, E type and B type all can connect expansion modules. The maximum expansions are: 3 Digital modes, 2 Analogue Output modes, 2 Analogue Input modules (each of 4PT and 4AI) and 1 Communication module. The sequence of these expansion modules must be as demonstrated below.

✘ SMT-4AI must be the last one of analogue module.

The digital models have 2 kinds: version 1.2 and version 3.0. They can connect with SMT together.

There are 3 kinds of connecting of expansion modules as shown below.

### Mainframe + digital IO (V1.2/V3.0) \* 3 + 4AI\*1+COMM.\*1

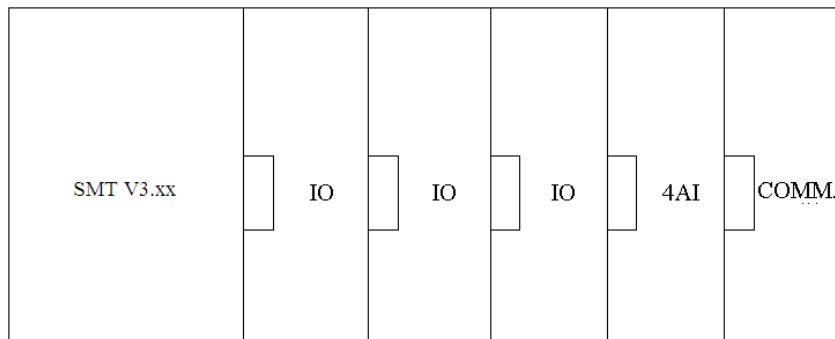

✘ digital IO: SMT-MA-R8, SMT-MD-R8, SMT-MD-T8, SMT-MA24-R8

✘ Digital IO version can be either 1.2 or 3.0

### Mainframe + digital IO (V1.2/V3.0) \* 3 + 2AO\*1/4PT\*1

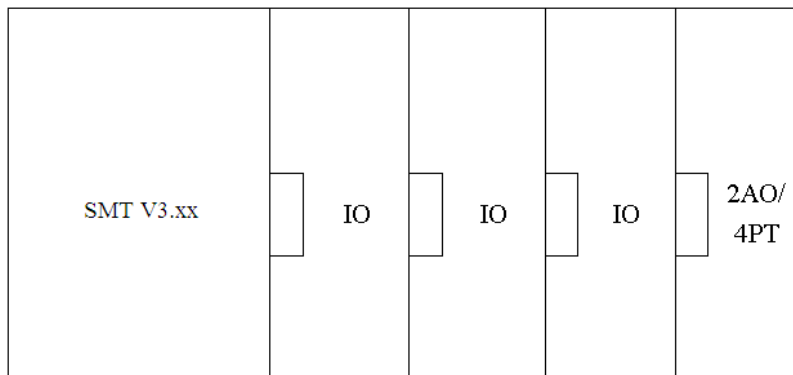

✘ digital IO: SMT SMT-MA-R8, SMT-MD-R8, SMT-MD-T8, SMT-MA24-R8

✘ Either 2AO or 4PT.

**Mainframe + digital IO (V3.0) \* 3+2AO\*2+4PT\*1+4AI\*1+ COMM.\*1**

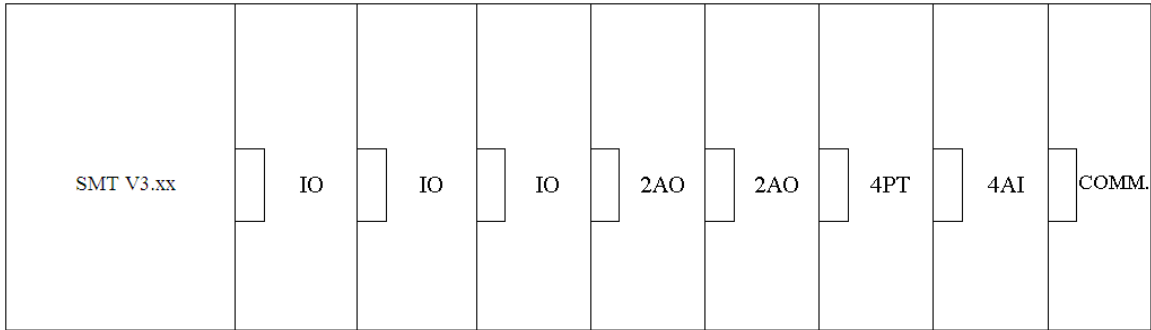

※ V3.0: Digital IO version is V3.0

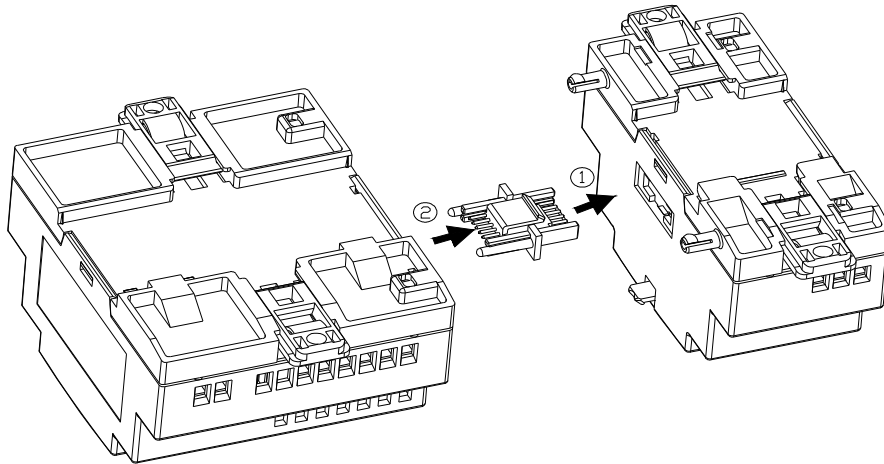

※ The method of all expansion modules connecting with SMT is the same as shown above.

※ The number of digital module must be accord with IO number set if there are other modules after digital module, But the IO number set can be less than connecting if there is no other expansion module after digital module.

### Digital IO module

The SMT must set the number of expansion IO when connect expansion module. The method of setting IO number is shown below.

#### 1) Keypad

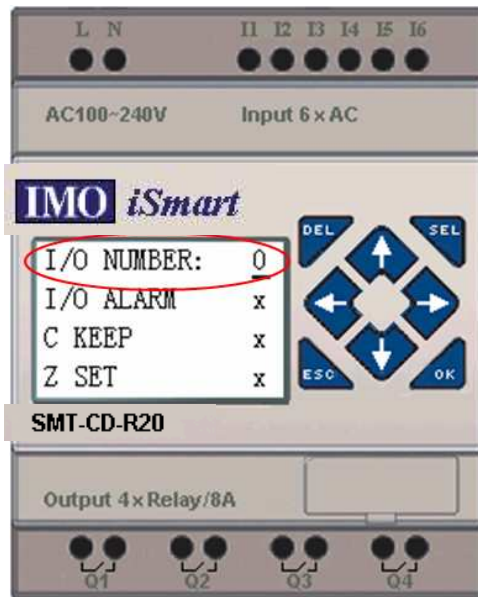

#### 2) SMT Client software

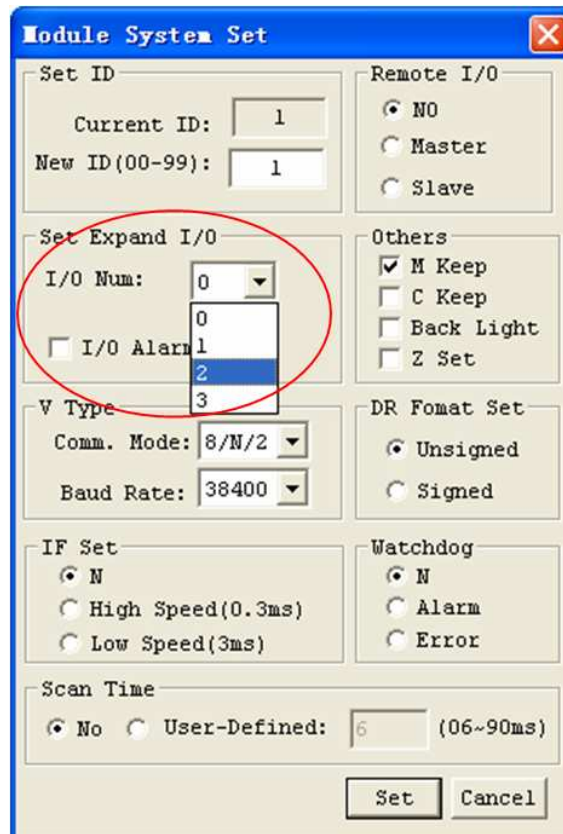

## Expansion display State

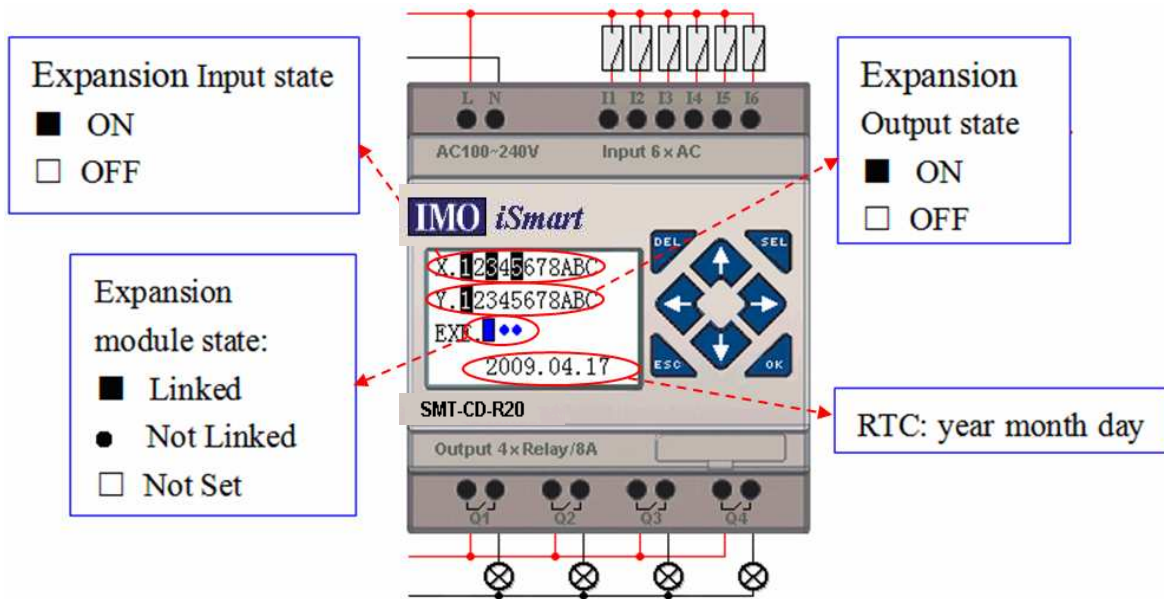

## Installation and Wiring

E type of expansion module: SMT-MD-R8/T8, SMT-MA-R8/MA24-R8

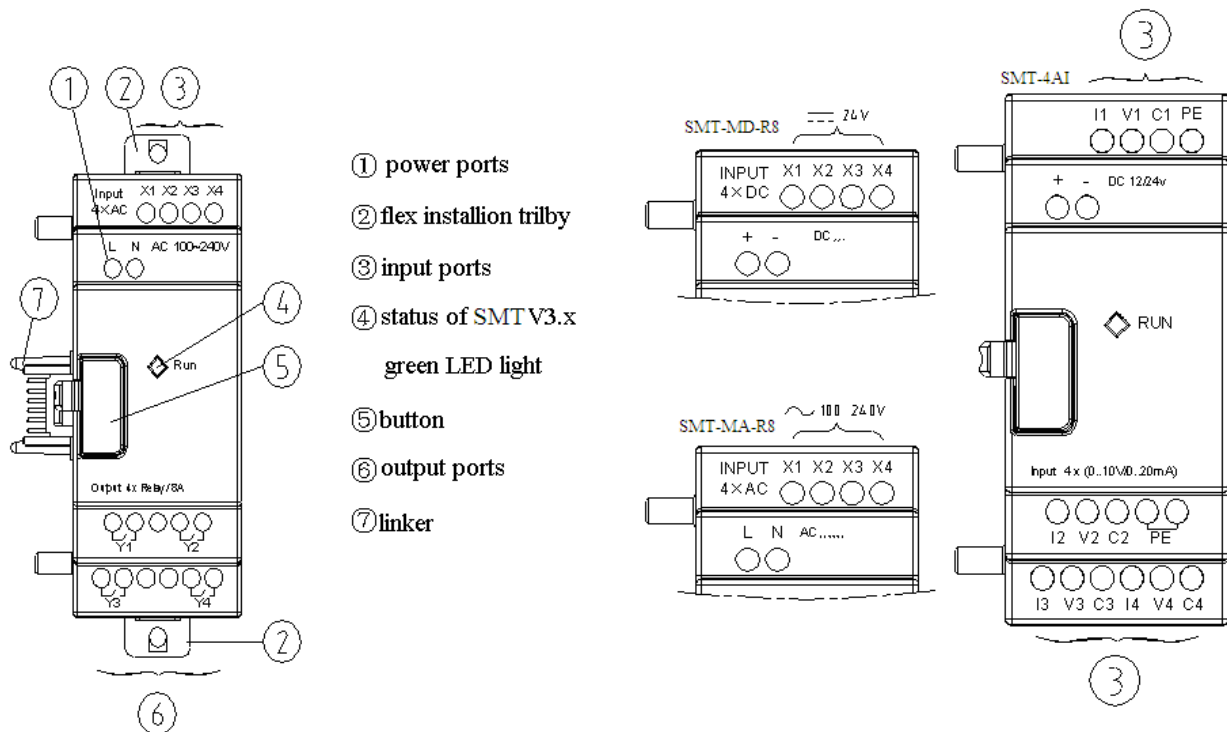

## Size of expansion module

※ All the expansion modules' size is the same as shown below.

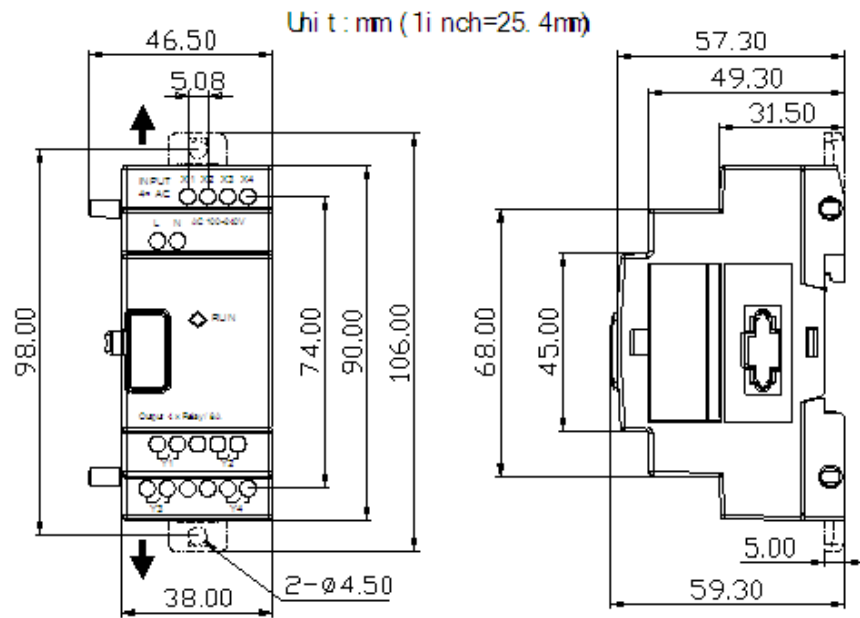

## Installation

※ All the expansion modules' installation method is the same as shown below.

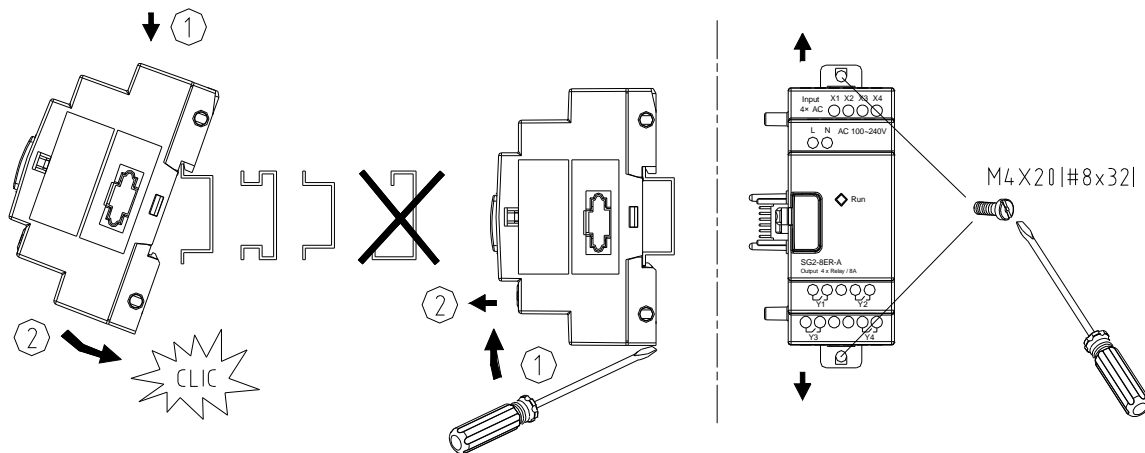

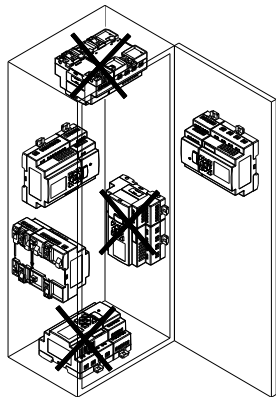
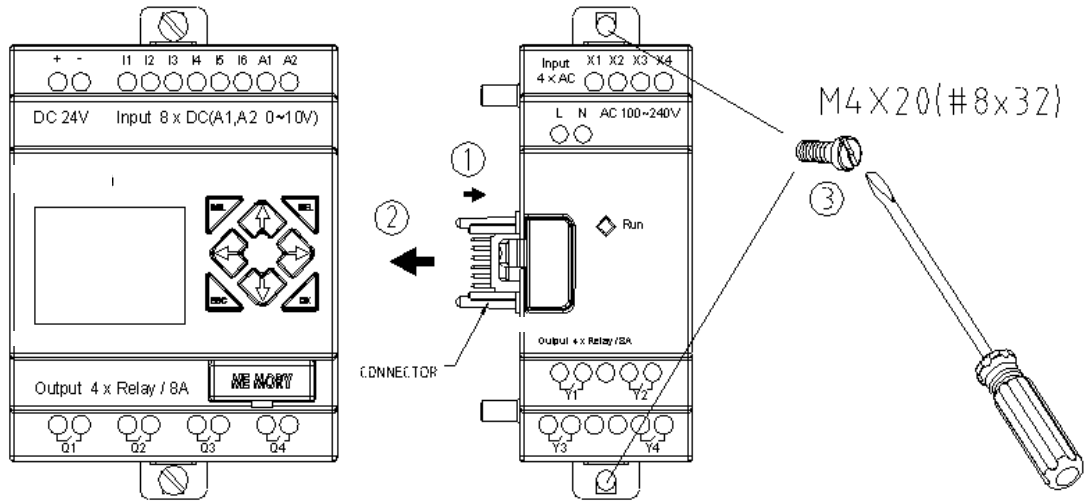
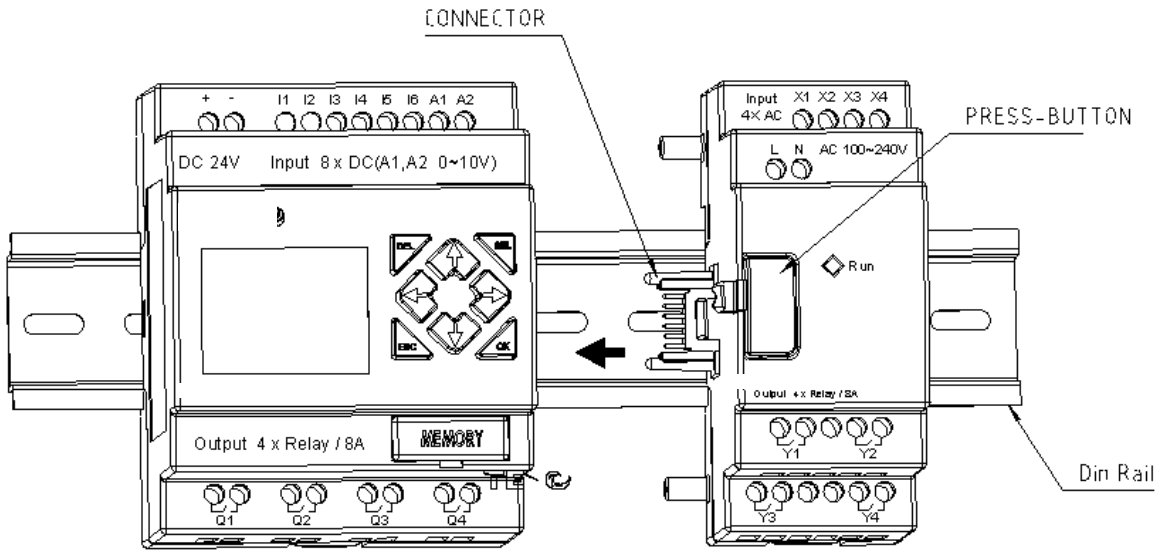

mm <sup>2</sup>	0.14...1.5	0.14...0.75	0.14...2.5	0.14...2.5	0.14...1.5
AWG	26...16	26...18	26...14	26...14	26...16
 ø 3.5 (0.14in)	C		C		
			Nm	0.6	
		lb-in	5.4		

※ Please do power down before maintaining equipment.

## Wiring

### 1) 24V DC power input

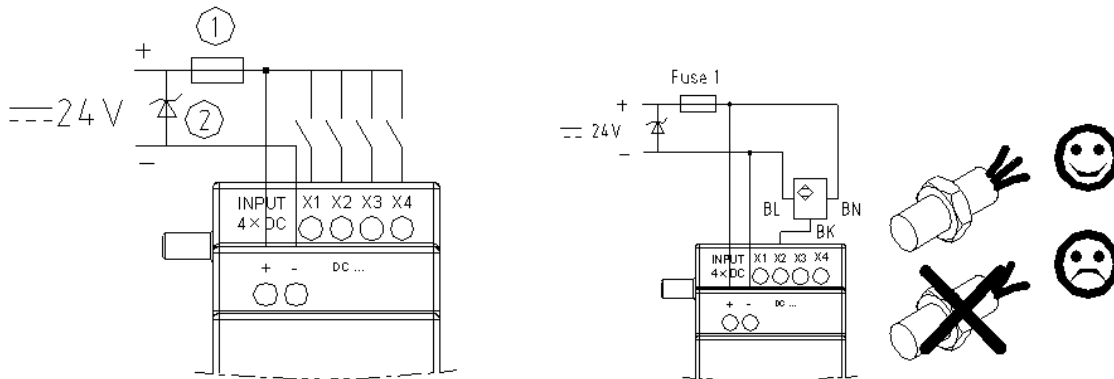

### 2) 24V/100~240V AC power input

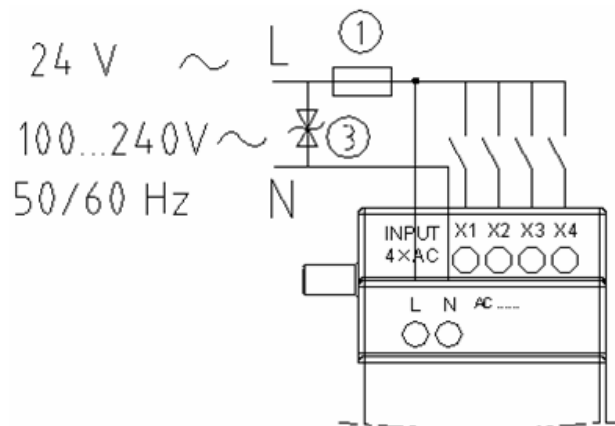

### 3) Relay output

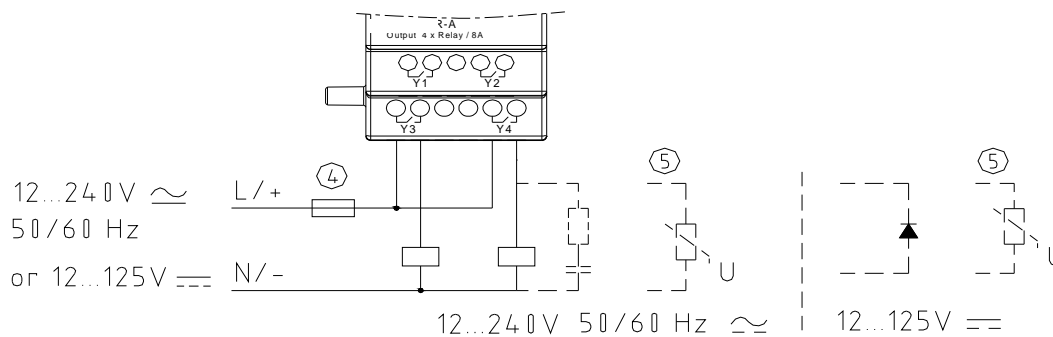

### 4) Transistor output

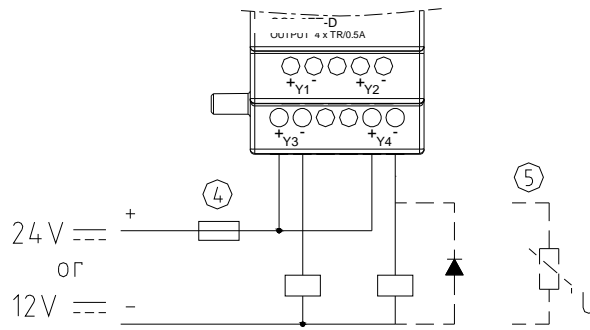

①-1A quick-blowing fuse, circuit-breaker or circuit protector

②-Surge absorber (36V DC)

③-Surge absorber (400V AC)

④-Fuse, circuit-breaker or circuit protector

⑤-Inductive load

※ AC inductive load needs parallel connect Surge absorber to describe noise if the SMT output is relay.  
 DC inductive load needs parallel connect commute diode if the SMT output is relay. The commute diode 's inverted voltage should be more than 5~10 times of load voltage, and the positive current should be more than load current. Inductive load needs parallel connect commute diode if the SMT output is transistor.

Digital IO module and Analogue module both have indicator light. The state of indicator light is the same  
 The state of indicator light is shown below.

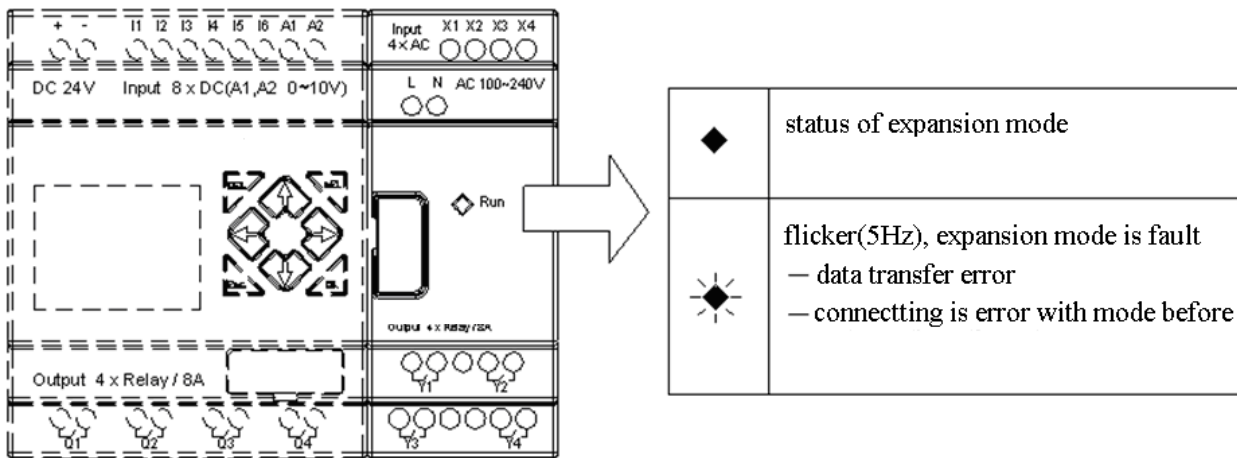



### Analogue module

The maximum Analogue expansion modules to an SMT is 2 2AO, 1 4PT and 1 4AI. The first 2AO corresponds with AQ01~AQ02, and the next 2AO corresponds with AQ03~AQ04. The 4 inputs of 4AI corresponds to A05~A08.

The current value of 2AO output displaying as shown below:

A Q 0 1 = 0 0 . 0 0 V
A Q 0 2 = 0 0 . 0 0 V
A Q 0 3 = 0 0 . 0 0 V
A Q 0 4 = 0 0 . 0 0 V

The current value of 4PT input displaying as shown below:

A T 0 1 = 0 0 0 0 . 0 °C
A T 0 2 = 0 0 0 0 . 0 °C
A T 0 3 = 0 0 0 0 . 0 °C
A T 0 4 = 0 0 0 0 . 0 °C

The current value of 4AI input displaying as shown below:

A 0 5 = 0 0 . 0 0 V
A 0 6 = 0 0 . 0 0 V
A 0 7 = 0 0 . 0 0 V
A 0 8 = 0 0 . 0 0 V

### Wiring

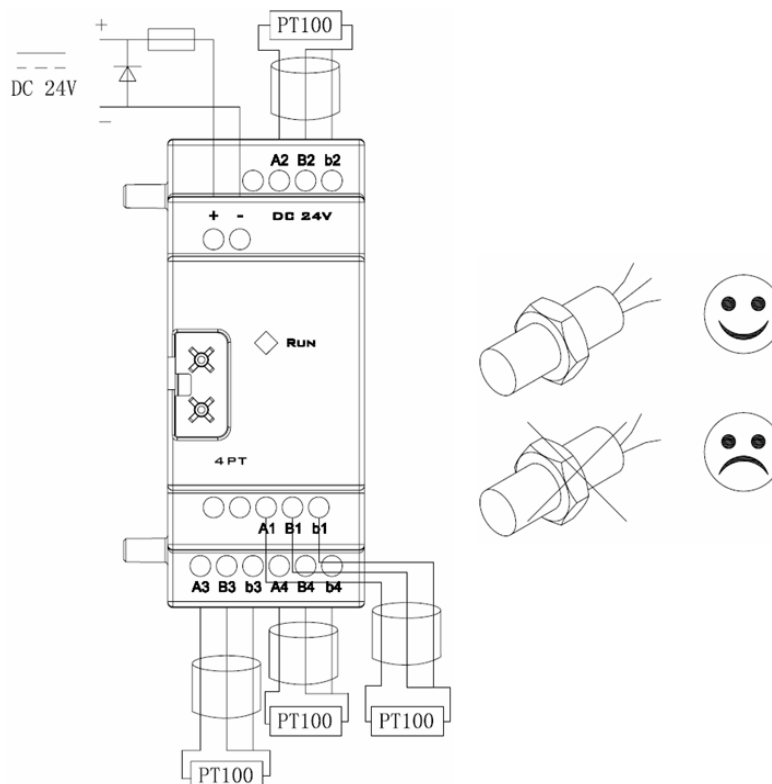

SMT-4PT

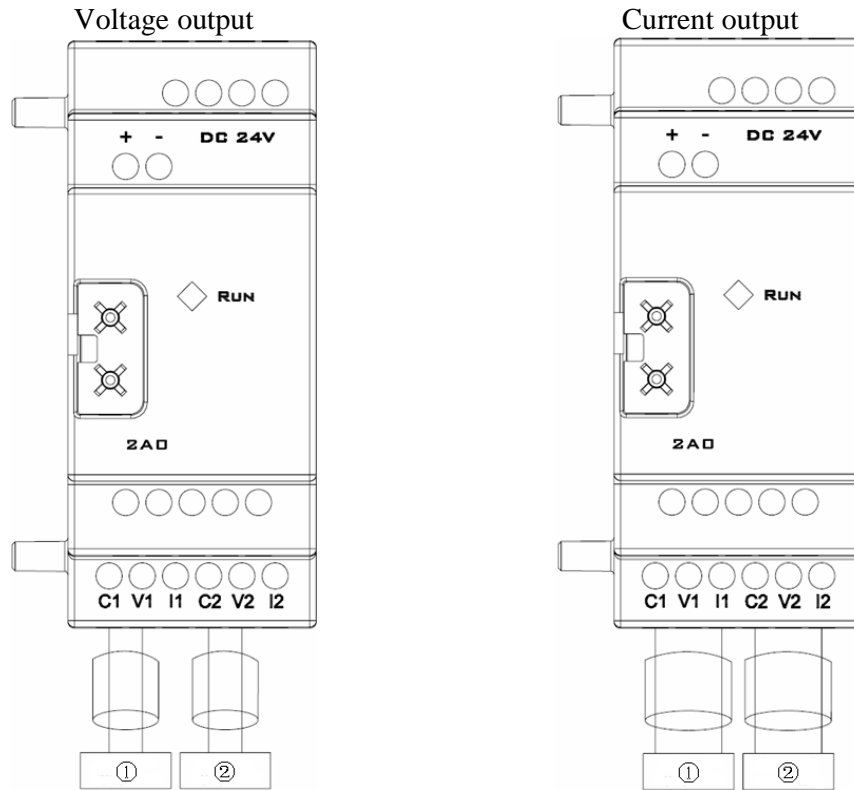

SMT-2AO

	Content	standard	
4PT	Temperature input range	-100°C~600°C	
	Digital output	-100.0°C~600.0°C	
	Differentiation	2.5mV	
	Definition	±0.5%	
2AO		voltage	current
	Analogue output range	0V~10V Load impedance should be bigger than 500Ω	0mA~20mA Load impedance should be smaller than 500Ω
	Differentiation	10mV	10μA
	Digital output	0.00V~10.00V	0.00mA~20.00mA
	Register value	0~1000	0~500
	Definition	±2.5%	±2.5%

The input value of SMT-4PT is over range if wiring error or no input, SMT will not receive and store the value of corresponding channel, and the corresponding channel's coil M turns ON.

Coil	AT number	
M34	AT01	SMT-4PT channel 1 error
M35	AT02	SMT-4PT channel 2 error
M36	AT03	SMT-4PT channel 3 error
M37	AT04	SMT-4PT channel 4 error

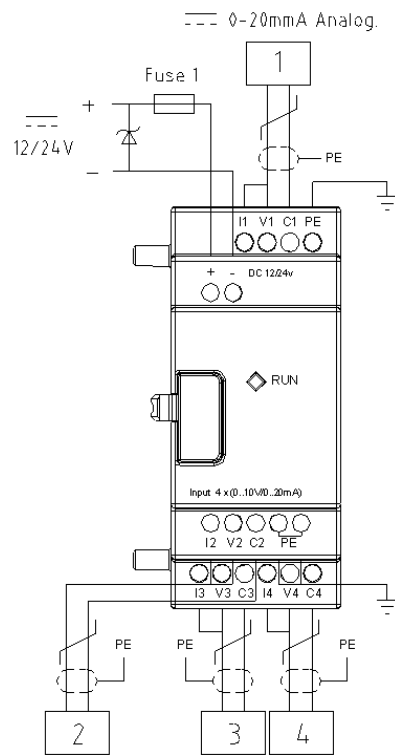
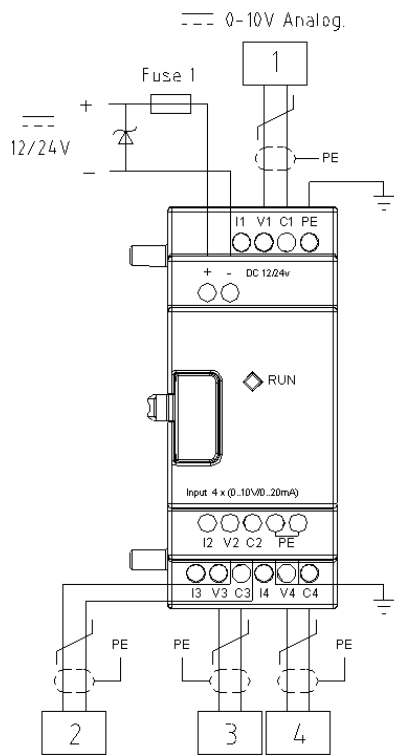

SMT-4AI

## Communication module

### ModBus module

#### Summarize

SMT-MODBUS module adds Modbus RS485 slave communication, to a non-CD type model. SMT-MODBUS works as RTU slave node, responses RTU master node's request, but it cannot be a Master. SMT-MODBUS also increases the scan period of the unit, it is different depending on the Modbus command (Read/Write). Normally, this increase is less than 20ms, but it will be 100ms if the Modbus command is to alter the preset value of a function.

#### SMT-MODBUS Cell Configuration

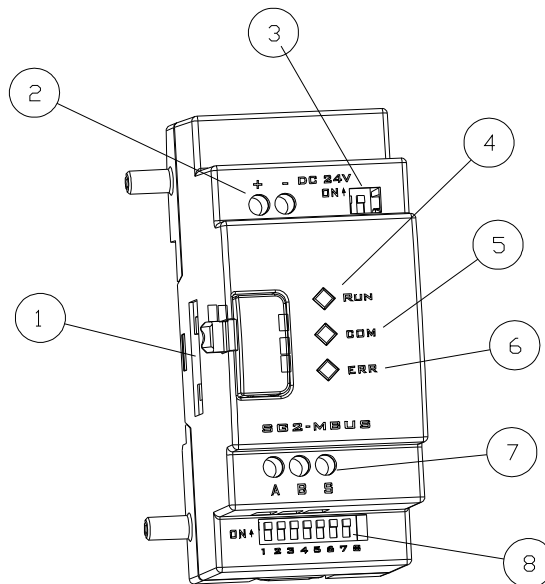

- ①: Connecting port
- ②: Power
- ③: SW2, 2-bit switch (terminal resistance selection)
- ④: RUN, running LED light
- ⑤: COMM. Communication LED light
- ⑥: Error, state LED light
- ⑦: RS 485 port
- ⑧: SW1, 8-bit switch (set format of communication)

#### Connect with electrical source

SMT-MODBUS required a 24V DC power supply

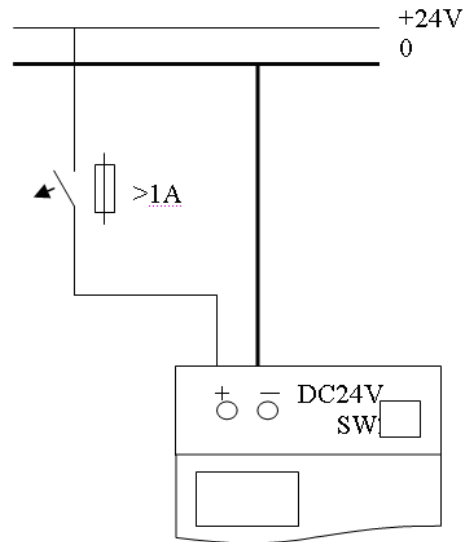

### Communication set

The SMT-MODBUS communication baud rate and format can be set by 8 bits switch (DIP) SW1.

#### Baud rate

SW1-3~SW1-1 set communication baud rate is 57.6K, 38.4K, 19.2K, 9.6K, 4.8K as shown below.

SW1-6	SW1-3	SW1-2	SW1-1	Baud rate (Kbps)
OFF	OFF	OFF	OFF	4.8
OFF	OFF	OFF	ON	9.6
OFF	OFF	ON	OFF	19.2
OFF	OFF	ON	ON	38.4
OFF	ON	*	*	57.6
ON	*	*	*	38.4

※ \*can be ON or OFF

#### Verifying bit and stop bit set

SW1-4, sets stop bit and verifying bit

SW1-5, sets verifying format (SW1-4= 1 availability)

SW1-6, assembled set

SW1-7~SW1-8, reserved

More information as shown below:

SW1-8	SW1-7	SW1-6	SW1-5	SW1-4	Stop bit, verifying bit, assembled set
*	*	OFF	*	OFF	2 stop bits, no verifying bit
*	*	OFF	OFF	ON	1 stop bit, 1 odd verifying bit
*	*	OFF	ON	ON	1 stop bit, 1 even verifying bit
*	*	ON	*	*	SW1-1~SW1-5 are inefficacy, communication format is default as 38.4Kbps, 2 stop bits, no verifying bit

※ \* can be ON or OFF

### State indication and unconventionality manage

Error code	State indication	Error type and reason	Manage method	Comment
56H	The error LED light flick slow (2Hz)	The connection between SMT and COMM. Mode is improper	check-up connection among SMT, IO mode and COMM. Mode	The question is connection with the mode before it if there are many expansion modes.
55H	The error LED light is ON	SMT set error: IO number set is different from factual.	check-up SMT set	
51H、54H	The error LED light flick slow (2Hz)	ModBus order error: data frames, function code, address of register, CRC , data unseemliness, verifying error, etc.	check-up the order and communication set according COMM. protocol	
59H	The error LED light flick quickly(5Hz)	COMM. data error: Verifying bit error, Length of data respond error, CRC error	Make sure the connection between SMT and COMM. Mode is credible, describe environment interfere.	

※ More information to see SMT-MODBUS user manual.

## DeviceNet COMM. Module

### Summarize

SMT-DNET adds DeviceNet slave functionality to a unit. At DeviceNet side, SMT-DNET is for GROUP 2 ONLY equipment, slave equipment in this network. At PLC side, SMT-DNET communicate with SMT through SMT COMM. Port, it is point-to-point communication equipment. SMT-DNET is together with SMT as one slave equipment in DeviceNet network.

### SMT-DNET Cell Configuration

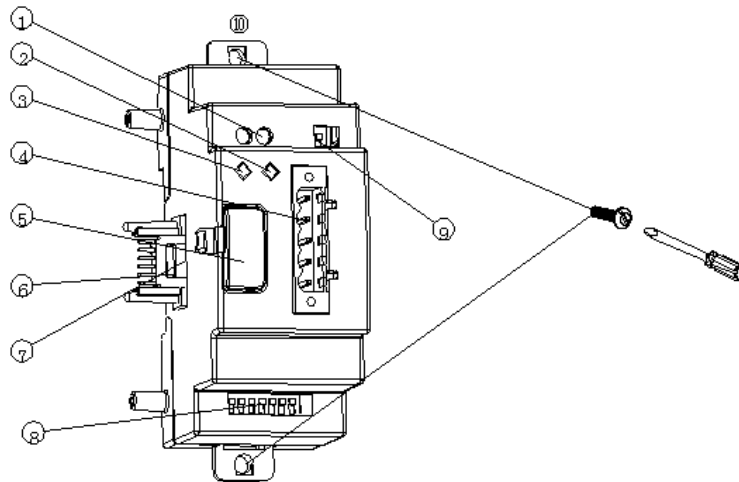

- ①: 24V DC power supply port
- ②: Network state LED light NS
- ③: Mode state LED light MS
- ④: 5-pin DeviceNet port
- ⑤: Release Button
- ⑥: Linker
- ⑦: Port connection with SMT
- ⑧: SW1, 8-bit switch (set network's ID and baud rate)
- ⑨: SW2, 2-bit switch (network terminal resistance selection)
- ⑩: Flexed installation feet

## Connect with DeviceNet network

Using 5-pin network tie-in, connect SMT-DNET to DeviceNet bus. Please use network tie-in and cable obtained by ODVA. The style of cable decides the maximal length and baud rate of the network.

Ports assign

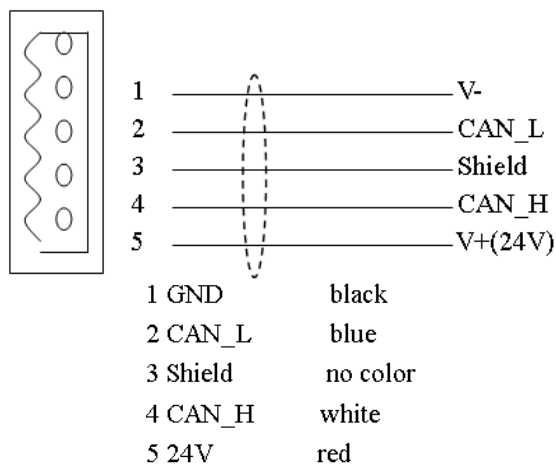

## Address and COMM. Baud rate set

In equipment network, each slave node needs a difference MAC ID, and the maximal number of ID is 64 (0~63). The address of node can be set by SW1-1~SW1-6 of SMT-DNET oneself mode. And the baud rate of communication can be set by SW1-7 and SW1-8, the baud rate set must be the same as equipment network.

SW1 setting

ID in network	SW1_6~SW1_1	000000	ID: 0
		000001	ID: 1
		.....	.....
		111110	ID: 62
		111111	ID: 63
Baud rate	SW1_8~SW1_7	00	Baud rate: 125K
		01	Baud rate: 250K
		10	Baud rate: 500K
		11	standby (default baud rate: 125K)

## LED state display



SMT-DNET has two LED lights, watching itself and COMM. Bus' state.

1) mode state LED (MS)

Double colour LED (green and red) indicates SMT-DNET state.

<b>Module status LED</b>	<b>Explanation</b>	<b>Correct or prevent fault</b>
Off	No power	Power up
Green on	Normal operation status	No
Green flash	No connected with SMT basic unit	Connected with SMT correctly.
Red flash	Connect with SMT but communication error.	Set SMT IO number correctly.
Red on	Device hardware error.	Use a new module.

2) network state LED (NS)

Double colour LED (green and red) indicates equipment network bus state.

<b>Net status LED</b>	<b>Explanation</b>	<b>Correct or prevent fault</b>
Off	·No power. ·The device is a single node in the net.	Power up. Add other device in the net.
Green on	Normal operation mode, and connected with master.	No
Green flash	Normal operation mode, but not connected with master or had be set free	No
Red flash	IO connection time out, waiting green flash after a few seconds.	No
Red on	·Dup_mac_id check error ·Communication error and restart	Replace node address and power up again.

※ More information to see SMT-DNET user manual.

## ProfiBus

### Summarize

SMT-PBUS makes SMT, which can't work in ProfiBus DP network, to work in ProfiBus DP network. At ProfiBus DP side, SMT-PBUS mode is a gateway, a slave node in network. At PLC side, SMT-PBUS communicate with SMT through SMT COMM. Port, it is point-to-point communication equipment. SMT-PBUS is together with SMT as one slave equipment in ProfiBus DP network.

### SMT-PBUS Cell Configuration

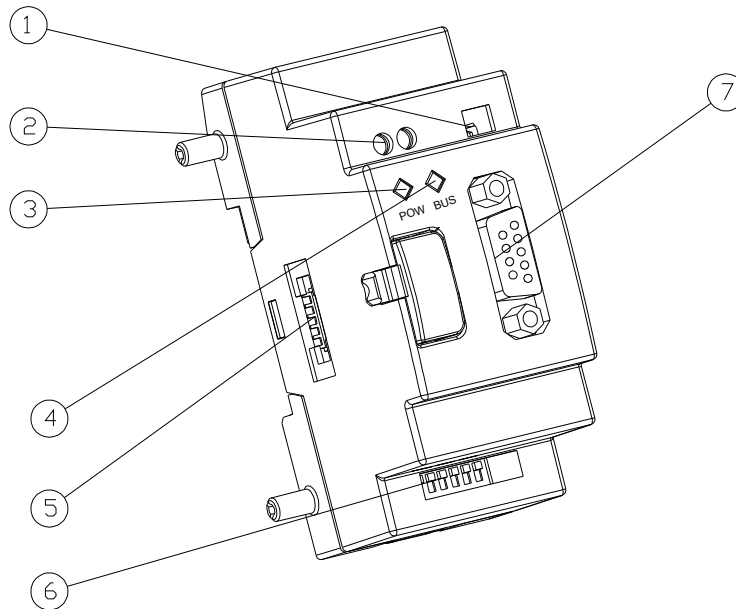

- ①: 2-bit switch (terminal resistance selection)
- ②: 24V DC power supply port
- ③: Power indicate light
- ④: BUS indicate light
- ⑤: Port connection with SMT
- ⑥: 8-bit switch (slave node ID set)
- ⑦: 9-hole PROFIBUS DP socket

## Connection with Profibus Net

Using 9-hole pin to connect with PROFIBUS DP bus, please use the regulated pin and cable.

### Ports assign

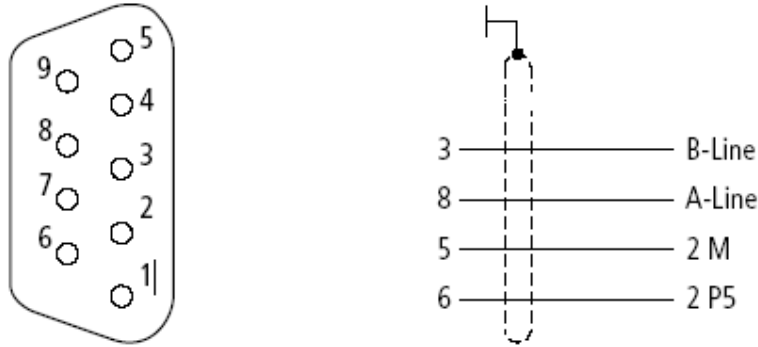

NO.	name	description
1	reserved	
2	reserved	
3	RxD/TxD-P (B-Line)	Send/receive data (positive)
4	reserved	
5	DGND (2M)	Digital GND
6	VP(2 P5)	+5V DC (supply bus expansion)
7	reserved	
8	RxD/TxD-N (A-Line)	Send/receive data (negative)
9	reserved	

### Baud rate adapt oneself and address set

After SMT-PBUS mode powers up, it can identify the baud rate on Profibus automatically when at least one master sends right message. The baud rate range is: 9.6Kbit/s ~6Mbit/s. In equipment network, each slave node has a difference ID, and the maximal number of ID is 127 (0~126). Its ID can be set by 8-bit switch integration on itself.

SW_7	SW-6	SW-5	SW-4	SW-3	SW-2	SW-1	ID
OFF	OFF	OFF	OFF	OFF	OFF	OFF	0
OFF	OFF	OFF	OFF	OFF	OFF	ON	1
OFF	OFF	OFF	OFF	OFF	ON	OFF	2
OFF	OFF	OFF	OFF	OFF	ON	ON	3
OFF	OFF	OFF	OFF	ON	OFF	OFF	4
...	...	...	...	...	...	...	...
ON	ON	ON	ON	ON	OFF	ON	125
ON	ON	ON	ON	ON	ON	OFF	126

※ The eighth bit is reserved.

## LED state display

SMT-PBUS mode has two number of double colour LED (green and red) used for fast diagnostics, to indicate the state of COMM. Bus and itself.

### 1) power LED

State of LED	Description
Green ON	natural
Yellow (red and green) flash (4Hz)	Hardware error
Yellow (red and green) flash (2Hz)	IO number error
Red flash (2Hz)	Connection with SMT error
Red flash (1Hz)	Read/write order COMM. With Network bus error
OFF	Power down

### 2) BUS LED

State of LED	Description
Green ON	Connect with DP Net and communication right
OFF	Not connect with DP Net

※ More information to see SMT-PBUS user manual.

## Appendix: Keypad Programming

### Appendix A: Keypad programming in Ladder mode

Operation Sample:

	1	2	3	4	5	6	7	8	Column
Line 1	>	L	A	D	D	E	R		
2		F	U	N	.	B	L	O	C
3		P	A	R	A	M	E	T	E
4		R	U	N					

Procedure 1 : Press 'OK'  Enter LADDER Edition	1	2	3	4	5	6	7	8	Column
Line 1									
2									
3									
4									

Procedure 2 : Press 'SEL'  (When cursor located at character or digital, press the button to show I01)	1	2	3	4	5	6	7	8	Column
Line 1	I	0	1						
2									
3									
4									

Procedure 3 : Press '↑' 3 times  (Press '↑ ↓', and the digital cursor located will change from I to G).	1	2	3	4	5	6	7	8	Column
Line 1	Q	0	1						
2									
3									
4									

Procedure 4 : Press 'SEL'  (start /end modifying parameter)	1	2	3	4	5	6	7	8	Column
Line 1	q	0	1						
2									
3									
4									

Procedure 5 : Press '→' 2 times  (Press '← →', the cursor located in digital)	1	2	3	4	5	6	7	8	Column
Line 1	q	0	1						
2									
3									
4									

Procedure 6 :	1	2	3	4	5	6	7	8	Column
---------------	---	---	---	---	---	---	---	---	--------

Press '↑' for 3 times  (Press '↑ ↓', the digital the cursor located will change from 1 to 4)	<table border="1"> <tr><td>Line 1</td><td>q</td><td>0</td><td>4</td><td></td><td></td><td></td><td></td></tr> <tr><td>2</td><td></td><td></td><td></td><td></td><td></td><td></td><td></td></tr> <tr><td>3</td><td></td><td></td><td></td><td></td><td></td><td></td><td></td></tr> <tr><td>4</td><td></td><td></td><td></td><td></td><td></td><td></td><td></td></tr> </table>	Line 1	q	0	4					2								3								4							
Line 1	q	0	4																														
2																																	
3																																	
4																																	

Procedure 7 : Press '←' 2 times  (Press 'SEL' + '← →' to move the cursor to the position Required revision.	<table border="1"> <tr> <td></td> <td>1</td> <td>2</td> <td>3</td> <td>4</td> <td>5</td> <td>6</td> <td>7</td> <td>8</td> <td>Column</td> </tr> <tr> <td>Line 1</td> <td>q</td> <td>0</td> <td>4</td> <td></td> <td></td> <td></td> <td></td> <td></td> <td></td> </tr> <tr><td>2</td><td></td><td></td><td></td><td></td><td></td><td></td><td></td><td></td><td></td></tr> <tr><td>3</td><td></td><td></td><td></td><td></td><td></td><td></td><td></td><td></td><td></td></tr> <tr><td>4</td><td></td><td></td><td></td><td></td><td></td><td></td><td></td><td></td><td></td></tr> </table>		1	2	3	4	5	6	7	8	Column	Line 1	q	0	4							2										3										4									
	1	2	3	4	5	6	7	8	Column																																										
Line 1	q	0	4																																																
2																																																			
3																																																			
4																																																			

OR

Automatically

Procedure 7 : Press 'OK'  (Move the cursor to character in column 3)	<table border="1"> <tr> <td></td> <td>1</td> <td>2</td> <td>3</td> <td>4</td> <td>5</td> <td>6</td> <td>7</td> <td>8</td> <td>Column</td> </tr> <tr> <td>Line 1</td> <td>q</td> <td>0</td> <td>4</td> <td>—</td> <td></td> <td></td> <td></td> <td></td> <td></td> </tr> <tr><td>2</td><td></td><td></td><td></td><td></td><td></td><td></td><td></td><td></td><td></td></tr> <tr><td>3</td><td></td><td></td><td></td><td></td><td></td><td></td><td></td><td></td><td></td></tr> <tr><td>4</td><td></td><td></td><td></td><td></td><td></td><td></td><td></td><td></td><td></td></tr> </table>		1	2	3	4	5	6	7	8	Column	Line 1	q	0	4	—						2										3										4									
	1	2	3	4	5	6	7	8	Column																																										
Line 1	q	0	4	—																																															
2																																																			
3																																																			
4																																																			

OR

Automatically Link

Procedure 7 : Press '→'  (move the cursor to the link location in column 2)	<table border="1"> <tr> <td></td> <td>1</td> <td>2</td> <td>3</td> <td>4</td> <td>5</td> <td>6</td> <td>7</td> <td>8</td> <td>Column</td> </tr> <tr> <td>Line 1</td> <td>q</td> <td>0</td> <td>4</td> <td>—</td> <td></td> <td></td> <td></td> <td></td> <td></td> </tr> <tr><td>2</td><td></td><td></td><td></td><td></td><td></td><td></td><td></td><td></td><td></td></tr> <tr><td>3</td><td></td><td></td><td></td><td></td><td></td><td></td><td></td><td></td><td></td></tr> <tr><td>4</td><td></td><td></td><td></td><td></td><td></td><td></td><td></td><td></td><td></td></tr> </table>		1	2	3	4	5	6	7	8	Column	Line 1	q	0	4	—						2										3										4									
	1	2	3	4	5	6	7	8	Column																																										
Line 1	q	0	4	—																																															
2																																																			
3																																																			
4																																																			

Repeat the step1~7, and input M01, I03 Instruction to column 3, 5.

Procedure 8 : Press 'OK' in Column 5  (move the cursor to the character in column 8)	<table border="1"> <tr> <td></td> <td>1</td> <td>2</td> <td>3</td> <td>4</td> <td>5</td> <td>6</td> <td>7</td> <td>8</td> <td>Column</td> </tr> <tr> <td>Line 1</td> <td>q</td> <td>0</td> <td>4</td> <td>—</td> <td>M 0 1</td> <td>—</td> <td>I 0 3</td> <td>—</td> <td></td> </tr> <tr><td>2</td><td></td><td></td><td></td><td></td><td></td><td></td><td></td><td></td><td></td></tr> <tr><td>3</td><td></td><td></td><td></td><td></td><td></td><td></td><td></td><td></td><td></td></tr> <tr><td>4</td><td></td><td></td><td></td><td></td><td></td><td></td><td></td><td></td><td></td></tr> </table>		1	2	3	4	5	6	7	8	Column	Line 1	q	0	4	—	M 0 1	—	I 0 3	—		2										3										4									
	1	2	3	4	5	6	7	8	Column																																										
Line 1	q	0	4	—	M 0 1	—	I 0 3	—																																											
2																																																			
3																																																			
4																																																			

Procedure 9 : Press 'SEL'  (when the cursor located at character and digital, press 'SEL' to show '( Q01')	<table border="1"> <tr> <td></td> <td>1</td> <td>2</td> <td>3</td> <td>4</td> <td>5</td> <td>6</td> <td>7</td> <td>8</td> <td>Column</td> </tr> <tr> <td>Line 1</td> <td>q</td> <td>0</td> <td>4</td> <td>—</td> <td>M 0 1</td> <td>—</td> <td>I 0 3</td> <td>—</td> <td>( Q 0 1</td> </tr> <tr><td>2</td><td></td><td></td><td></td><td></td><td></td><td></td><td></td><td></td><td></td></tr> <tr><td>3</td><td></td><td></td><td></td><td></td><td></td><td></td><td></td><td></td><td></td></tr> <tr><td>4</td><td></td><td></td><td></td><td></td><td></td><td></td><td></td><td></td><td></td></tr> </table>		1	2	3	4	5	6	7	8	Column	Line 1	q	0	4	—	M 0 1	—	I 0 3	—	( Q 0 1	2										3										4									
	1	2	3	4	5	6	7	8	Column																																										
Line 1	q	0	4	—	M 0 1	—	I 0 3	—	( Q 0 1																																										
2																																																			
3																																																			
4																																																			

Auto Add "( "

Procedure 10 : Press 'OK'	<table border="1"> <tr> <td></td> <td>1</td> <td>2</td> <td>3</td> <td>4</td> <td>5</td> <td>6</td> <td>7</td> <td>8</td> <td>Column</td> </tr> <tr> <td>Line 1</td> <td>q</td> <td>0</td> <td>4</td> <td>—</td> <td>M 0 1</td> <td>—</td> <td>I 0 3</td> <td>—</td> <td>( Q 0 1</td> </tr> <tr><td>2</td><td></td><td></td><td></td><td></td><td></td><td></td><td></td><td></td><td></td></tr> </table>		1	2	3	4	5	6	7	8	Column	Line 1	q	0	4	—	M 0 1	—	I 0 3	—	( Q 0 1	2									
	1	2	3	4	5	6	7	8	Column																						
Line 1	q	0	4	—	M 0 1	—	I 0 3	—	( Q 0 1																						
2																															

Save the input program data, the position of the cursor will not move.	3 4
--	--------

Procedure 11 : Press '→' 3 times (Move the cursor to column 1 and Line 2.)	<table border="1"> <tr> <td></td> <td>:1</td> <td>:2:3</td> <td>:4:5</td> <td>:6:7:8</td> <td>:Column</td> </tr> <tr> <td>Line 1</td> <td>q</td> <td>0 4</td> <td>— M 0 1</td> <td>— I 0 3</td> <td>— ( Q 0 1</td> </tr> <tr> <td>2</td> <td>█</td> <td></td> <td></td> <td></td> <td></td> </tr> <tr> <td>3</td> <td></td> <td></td> <td></td> <td></td> <td></td> </tr> <tr> <td>4</td> <td></td> <td></td> <td></td> <td></td> <td></td> </tr> </table>		:1	:2:3	:4:5	:6:7:8	:Column	Line 1	q	0 4	— M 0 1	— I 0 3	— ( Q 0 1	2	█					3						4					
	:1	:2:3	:4:5	:6:7:8	:Column																										
Line 1	q	0 4	— M 0 1	— I 0 3	— ( Q 0 1																										
2	█																														
3																															
4																															

Procedure 12 : Press '→' 3 times (move the cursor to column 2) Note: never press 'SEL' before hand	<table border="1"> <tr> <td></td> <td>:1</td> <td>:2:3</td> <td>:4:5</td> <td>:6:7:8</td> <td>:Column</td> </tr> <tr> <td>Line 1</td> <td>q</td> <td>0 4</td> <td>— M 0 1</td> <td>— I 0 3</td> <td>— ( Q 0 1</td> </tr> <tr> <td>2</td> <td></td> <td>█</td> <td></td> <td></td> <td></td> </tr> <tr> <td>3</td> <td></td> <td></td> <td></td> <td></td> <td></td> </tr> <tr> <td>4</td> <td></td> <td></td> <td></td> <td></td> <td></td> </tr> </table>		:1	:2:3	:4:5	:6:7:8	:Column	Line 1	q	0 4	— M 0 1	— I 0 3	— ( Q 0 1	2		█				3						4					
	:1	:2:3	:4:5	:6:7:8	:Column																										
Line 1	q	0 4	— M 0 1	— I 0 3	— ( Q 0 1																										
2		█																													
3																															
4																															

Change Wire '—' to 'I'

Procedure 13 : Press 'SEL' (A vertical line emerges)	<table border="1"> <tr> <td></td> <td>:1</td> <td>:2:3</td> <td>:4:5</td> <td>:6:7:8</td> <td>:Column</td> </tr> <tr> <td>Line 1</td> <td>q</td> <td>0 4</td> <td>I M 0 1</td> <td>— I 0 3</td> <td>— ( Q 0 1</td> </tr> <tr> <td>2</td> <td></td> <td></td> <td>┆</td> <td></td> <td></td> </tr> <tr> <td>3</td> <td></td> <td></td> <td>—</td> <td></td> <td></td> </tr> <tr> <td>4</td> <td></td> <td></td> <td></td> <td></td> <td></td> </tr> </table>		:1	:2:3	:4:5	:6:7:8	:Column	Line 1	q	0 4	I M 0 1	— I 0 3	— ( Q 0 1	2			┆			3			—			4					
	:1	:2:3	:4:5	:6:7:8	:Column																										
Line 1	q	0 4	I M 0 1	— I 0 3	— ( Q 0 1																										
2			┆																												
3			—																												
4																															

Procedure 14 : Press 'OK' (Move the cursor to character in column 3.)	<table border="1"> <tr> <td></td> <td>:1</td> <td>:2:3</td> <td>:4:5</td> <td>:6:7:8</td> <td>:Column</td> </tr> <tr> <td>Line 1</td> <td>q</td> <td>0 4</td> <td>I M 0 1</td> <td>— I 0 3</td> <td>— ( Q 0 1</td> </tr> <tr> <td>2</td> <td></td> <td></td> <td>┆</td> <td>█</td> <td></td> </tr> <tr> <td>3</td> <td></td> <td></td> <td></td> <td></td> <td></td> </tr> <tr> <td>4</td> <td></td> <td></td> <td></td> <td></td> <td></td> </tr> </table>		:1	:2:3	:4:5	:6:7:8	:Column	Line 1	q	0 4	I M 0 1	— I 0 3	— ( Q 0 1	2			┆	█		3						4					
	:1	:2:3	:4:5	:6:7:8	:Column																										
Line 1	q	0 4	I M 0 1	— I 0 3	— ( Q 0 1																										
2			┆	█																											
3																															
4																															

Repeat the step 1~7 and key in 'r0 3', '—' at Line 2 and column 3~6.

Procedure 15 : Press 'OK' in column 5 (move the cursor to the character in Column 8)	<table border="1"> <tr> <td></td> <td>:1</td> <td>:2:3</td> <td>:4:5</td> <td>:6:7:8</td> <td>:Column</td> </tr> <tr> <td>Line 1</td> <td>q</td> <td>0 4</td> <td>I M 0 1</td> <td>— I 0 3</td> <td>— ( Q 0 1</td> </tr> <tr> <td>2</td> <td></td> <td></td> <td>┆</td> <td>r 0 3</td> <td>----- █</td> </tr> <tr> <td>3</td> <td></td> <td></td> <td></td> <td></td> <td></td> </tr> <tr> <td>4</td> <td></td> <td></td> <td></td> <td></td> <td></td> </tr> </table>		:1	:2:3	:4:5	:6:7:8	:Column	Line 1	q	0 4	I M 0 1	— I 0 3	— ( Q 0 1	2			┆	r 0 3	----- █	3						4					
	:1	:2:3	:4:5	:6:7:8	:Column																										
Line 1	q	0 4	I M 0 1	— I 0 3	— ( Q 0 1																										
2			┆	r 0 3	----- █																										
3																															
4																															

Procedure 16 : Press 'SEL' (When the cursor located in digital or character, press 'SEL', 'Q01'	<table border="1"> <tr> <td></td> <td>:1</td> <td>:2:3</td> <td>:4:5</td> <td>:6:7:8</td> <td>:Column</td> </tr> <tr> <td>Line 1</td> <td>q</td> <td>0 4</td> <td>I M 0 1</td> <td>— I 0 3</td> <td>— ( Q 0 1</td> </tr> <tr> <td>2</td> <td></td> <td></td> <td>┆</td> <td>r 0 3</td> <td>----- ( Q 0 1</td> </tr> <tr> <td>3</td> <td></td> <td></td> <td></td> <td></td> <td></td> </tr> <tr> <td>4</td> <td></td> <td></td> <td></td> <td></td> <td></td> </tr> </table>		:1	:2:3	:4:5	:6:7:8	:Column	Line 1	q	0 4	I M 0 1	— I 0 3	— ( Q 0 1	2			┆	r 0 3	----- ( Q 0 1	3						4					
	:1	:2:3	:4:5	:6:7:8	:Column																										
Line 1	q	0 4	I M 0 1	— I 0 3	— ( Q 0 1																										
2			┆	r 0 3	----- ( Q 0 1																										
3																															
4																															

will  
emerges)

Auto Add “(”

<p>Procedure 17 :</p> <p>Press ‘↑’ for 5 times</p> <p>(Press ‘SEL’ + ‘↑↓’ (The character Q the cursor locating will change to C.)</p>		1	2:3	4:5	6:7:8	Column
	Line 1	q	0 4	T M 0 1	— I 0 3	— ( Q 0 1
	2			┘ r 0 3	—————	( C 0 1
	3					
4						

<p>Procedure 18 :</p> <p>Press ‘→’ 2 times</p>		1	2:3	4:5	6:7:8	Column
	Line 1	q	0 4	T M 0 1	— I 0 3	— ( Q 0 1
	2			┘ r 0 3	—————	( C 0 1
	3					
4						

<p>Procedure 19 :</p> <p>Press ‘↑’ for 6 times</p> <p>(The digital 1 the cursor locating will change to 7)</p>		1	2:3	4:5	6:7:8	Column
	Line 1	q	0 4	T M 0 1	— I 0 3	— ( Q 0 1
	2			┘ r 0 3	—————	( C 0 7
	3					
4						

Auto Enter  
Function Block

<p>Procedure 20 :</p> <p>Press ‘OK’</p> <p>(Auto shift to FUNCTION BLOCK and the counter input parameter)</p>		1	2:3	4:5	6:7:8	Column
	Line 1					
	2	L o w	┘	1		
	3			0	0 0 0 0 0	┘ C 0 7
4	L o w	┘				

<p>Procedure 21 :</p> <p>Press ‘ESC’ back to LADDER edition screen</p>		1	2:3	4:5	6:7:8	Column
	Line 1	q	0 4	T M 0 1	— I 0 3	— ( Q 0 1
	2			┘ r 0 3	—————	( C 0 7
	3					
4						

**Delete the Program Element**

		1	2:3	4:5	6:7:8	Column
Line 1	q	0 4	T M 0 1	— I 0 3	— ( Q 0 1	
2			┘ r 0 3	—————	( C 0 7	
3						
4						



Procedure : Press 'DEL'  (to delete the element C07 the cursor locating)		1	2:3	4:5	6:7:8	Column
	Line 1	q	0 4	T M 0 1	— I 0 3	— ( Q 0 1
	2			┆ r 0 3	—————	
	3					
	4					

**Display the present Line the cursor locating and operation state of SMT.**

Procedure : Press 'SEL+ESC' (simultaneously)  (The Line 4 displays where the cursor locating and operation state of SMT)		1	2:3	4:5	6:7:8	Column
	Line 1	q	0 4	T M 0 1	— I 0 3	— ( Q 0 1
	2			┆ r 0 3	—————	( C 0 7
	3					
	4	S	T O P	L I N E	0 0 2	

**Delete the whole Line**

		1	2:3	4:5	6:7:8	Column
Line 1	q	0 4	T M 0 1	— I 0 3	— ( Q 0 1	
2			┆ r 0 3	—————	( C 0 7	
3						
4						

Procedure : Press 'SEL+DEL' (Simultaneously)  ('ESC' Cancel , 'OK' Execute)		1	2:3	4:5	6:7:8	Column	
	Line 1	q	0 4	T M 0 1	— I 0 3	— ( Q 0 1	
	2			┆ r 0 3	—————	( C 0 7	
	3	C	L E A R	L n	0 0 2		
	4	E	S C	?	O K	?	

**Insert a whole line.**

	1	2:3	4:5	6:7:8	column
line 1	q	0 4	T M 0 1	— I 0 3 —	( Q 0 1
2			┘ r 0 3	—————	( C 0 7
3					
4					

Step:  
Press “SEL+OK” ( at the same time)

	1	2:3	4:5	6:7:8	column
Line 1	q	0 4	— M 0 1	— I 0 3 —	( Q 0 1
2			┘ r 0 3	—————	( C 0 7
3					
4					

**Turn page (move upward/ downward 4 lines program):**

	1	2:3	4:5	6:7:8	column
line 1	q	0 4	T M 0 1	— I 0 3 —	( Q 0 1
2			┘ r 0 3	—————	( C 0 7
3					
4					
5					

Step:  
Press ‘SEL+↑/↓’  
(at the same time)

	1	2:3	4:5	6:7:8	column
line 1	q	0 4	T M 0 1	— I 0 3 —	( Q 0 1
2			┘ r 0 3	—————	( C 0 7
3					
4					
5					

**Appendix B: Keypad programming in Ladder FUNCTION BLOCK**

	1	2:3	4:5	6:7:8	Column					
Line 1		L	A	D	D	E	R			
2	>	F	U	N	.	B	L	O	C	K
3		P	A	R	A	M	E	T	E	R
4		R	U	N						

Present action area  
The present value will appear when SMT is under

Procedure 1:  
Press ‘OK’  
  
(Enter FUNCTION BLOCK edition)

	1	2:3	4:5	6:7:8	Column
Line 1		┌	1	┐	
2		├		┤	
3			0.0	0.0	S e c
4					T 0 1
		└		┘	

Preset action value

	1	2:3	4:5	6:7:8	Column
--	---	-----	-----	-------	--------

Never press '→' to move to the digital position.  
 (If T02 is required to be changed,  
 Press '↑'/'↓' and 'SEL' to execute.)

Line	1	2	3	4
Line 1	1			
2	1			
3	0 0 . 0 0 S e c   T 0 1			
4	└┬┘			

Step 2: modify ①present target value ②preset the action relay

Preset the target value

Procedure 2-1:	1	2:3	4:5	6:7:8	Column
Press '←'					
(move the cursor to the preset action area)					
Line 1	1				
2	1				
3	0 0 . 0 0 S e c   T 0 1				
4	└┬┘				

Procedure 2-2:	1	2:3	4:5	6:7:8	Column
Press 'SEL'					
(begin input the target value)					
Line 1	1				
2	1				
3	0 0 . 0 0 S e c   T 0 1				
4	└┬┘				

Procedure 2-3:	1	2:3	4:5	6:7:8	Column
Press '↑' for 3 times					
(Press 'SEL' and followed by '↑,↓')					
The digital '0' is changed to '3')					
Line 1	1				
2	1				
3	0 0 . 0 3 S e c   T 0 1				
4	└┬┘				

Procedure 2-4:	1	2:3	4:5	6:7:8	Column
Press 'OK'					
(Save the input data)					
Line 1	1				
2	1				
3	0 0 . 0 3 S e c   T 0 1				
4	└┬┘				

Procedure 2-5:	1	2:3	4:5	6:7:8	Column
Press '←'					
Line 1	1				
2	1				
3	0 0 . 0 3 S e c   T 0 1				
4	└┬┘				

Repeat Step 2-2 ~ step 2-4 for 3 times, to enter the following screen:

Procedure 2-6:	1	2	3	4	5	6	7	8	Column	
	Line 1		1							
	2	1								
	3			3	.	3	S	e		c
	4							T		0

As the present value of the timer, counter, analogue input (A01-A08) and analogue gain value (V01-V08) is set as the preset value of them. Next to the step 2-2, to execute the following operation:

Step2-3A: Press 'SEL'	1	2	3	4	5	6	7	8	column	
	line 1		1							
	2	1								
	3			V	<u>0</u>	1	S	e		c
	4							T		0

Repeat the step 2-3A, the following screen will be shown in turn:

Step2-3B: Press 'SEL'	1	2	3	4	5	6	7	8	column	
	line 1		1							
	2	1								
	3			A	<u>0</u>	1	S	e		c
	4							T		0

Step 2-3C: press 'SEL'	1	2	3	4	5	6	7	8	column	
	line 1		1							
	2	1								
	3			T	<u>0</u>	1	S	e		c
	4							T		0

Step 2-3D: Press 'SEL'	1	2	3	4	5	6	7	8	column	
	line 1		1							
	2	1								
	3			C	<u>0</u>	1	S	e		c
	4							T		0

Step 2-3E: Press 'SEL'	1	2	3	4	5	6	7	8	column		
	line 1		1								
	2	1									
	3			A	T	<u>0</u>	1	S		e	c
	4							T		0	1

Step 2-3F:	1	2	3	4	5	6	7	8	column
------------	---	---	---	---	---	---	---	---	--------

Press 'SEL'	<pre> line 1      1 2           1 3           A Q <u>0</u> 1   S e c   } T 0 1 4                         </pre>
-------------	---

Step 2-3G: Press 'SEL'	<pre> :1  :2:3  :4:5  :6:7:8  :column line 1 2           1 3           D R <u>0</u> 1   S e c   } T 0 1 4                         </pre>
---------------------------	--

Step 2-3H: Press 'SEL'	<pre> :1  :2:3  :4:5  :6:7:8  :column line 1 2           1 3           A S <u>0</u> 1   S e c   } T 0 1 4                         </pre>
---------------------------	--

Step 2-3I: Press 'SEL'	<pre> :1  :2:3  :4:5  :6:7:8  :column line 1 2           1 3           M D <u>0</u> 1   S e c   } T 0 1 4                         </pre>
---------------------------	--

Step 2-3J: Press 'SEL'	<pre> :1  :2:3  :4:5  :6:7:8  :column line 1 2           1 3           P I <u>0</u> 1   S e c   } T 0 1 4                         </pre>
---------------------------	--

Step 2-3K: Press 'SEL'	<pre> :1  :2:3  :4:5  :6:7:8  :column line 1 2           1 3           M X <u>0</u> 1   S e c   } T 0 1 4                         </pre>
---------------------------	--

Step 2-3L: Press 'SEL'	<pre> :1  :2:3  :4:5  :6:7:8  :column line 1 2           1 3           A R <u>0</u> 1   S e c   } T 0 1 4                         </pre>
---------------------------	--

Next to step 2-3B, the following screen will be shown.

step 2-4B: Press '→', press '↑'	<table border="1"> <tr> <td></td> <td>1</td> <td>2</td> <td>3</td> <td>4</td> <td>5</td> <td>6</td> <td>7</td> <td>8</td> <td>column</td> </tr> <tr> <td>line 1</td> <td></td> <td></td> <td>1</td> <td></td> <td></td> <td></td> <td></td> <td></td> <td></td> </tr> <tr> <td>2</td> <td>1</td> <td> </td> <td></td> <td></td> <td></td> <td></td> <td></td> <td></td> <td></td> </tr> <tr> <td>3</td> <td></td> <td> </td> <td>A 0</td> <td><u>2</u></td> <td>S e c</td> <td> </td> <td>T 0 1</td> <td></td> <td></td> </tr> <tr> <td>4</td> <td></td> <td> </td> <td></td> <td></td> <td></td> <td></td> <td></td> <td></td> <td></td> </tr> </table>		1	2	3	4	5	6	7	8	column	line 1			1							2	1									3			A 0	<u>2</u>	S e c		T 0 1			4									
	1	2	3	4	5	6	7	8	column																																										
line 1			1																																																
2	1																																																		
3			A 0	<u>2</u>	S e c		T 0 1																																												
4																																																			

Repeat step2-4B (press '↓' is also available), the preset value of A01-A08 will be periodically changed. And so on. 'Analogue\*gain + offset' value (V01-V08) and the other function blocks (time, counter...) present value is set as preset value, to repeat the step to select T01-T1F, C01-C1F, V01-V08.

step 2-5B: press 'OK'  Save the present data.	<table border="1"> <tr> <td></td> <td>1</td> <td>2</td> <td>3</td> <td>4</td> <td>5</td> <td>6</td> <td>7</td> <td>8</td> <td>column</td> </tr> <tr> <td>line 1</td> <td></td> <td></td> <td>1</td> <td></td> <td></td> <td></td> <td></td> <td></td> <td></td> </tr> <tr> <td>2</td> <td>1</td> <td> </td> <td></td> <td></td> <td></td> <td></td> <td></td> <td></td> <td></td> </tr> <tr> <td>3</td> <td></td> <td> </td> <td>A 0</td> <td>2</td> <td>S e c</td> <td> </td> <td>T 0 1</td> <td></td> <td></td> </tr> <tr> <td>4</td> <td></td> <td> </td> <td></td> <td></td> <td></td> <td></td> <td></td> <td></td> <td></td> </tr> </table>		1	2	3	4	5	6	7	8	column	line 1			1							2	1									3			A 0	2	S e c		T 0 1			4									
	1	2	3	4	5	6	7	8	column																																										
line 1			1																																																
2	1																																																		
3			A 0	2	S e c		T 0 1																																												
4																																																			

Procedure 2-7: Press '↑'	<table border="1"> <tr> <td></td> <td>1</td> <td>2</td> <td>3</td> <td>4</td> <td>5</td> <td>6</td> <td>7</td> <td>8</td> <td>Column</td> </tr> <tr> <td>Line 1</td> <td></td> <td></td> <td>1</td> <td></td> <td></td> <td></td> <td></td> <td></td> <td></td> </tr> <tr> <td>2</td> <td>1</td> <td> </td> <td></td> <td></td> <td></td> <td></td> <td></td> <td></td> <td></td> </tr> <tr> <td>3</td> <td></td> <td> </td> <td>3 3 . 3 3</td> <td>S e c</td> <td> </td> <td>T 0 1</td> <td></td> <td></td> <td></td> </tr> <tr> <td>4</td> <td></td> <td> </td> <td></td> <td></td> <td></td> <td></td> <td></td> <td></td> <td></td> </tr> </table>		1	2	3	4	5	6	7	8	Column	Line 1			1							2	1									3			3 3 . 3 3	S e c		T 0 1				4									
	1	2	3	4	5	6	7	8	Column																																										
Line 1			1																																																
2	1																																																		
3			3 3 . 3 3	S e c		T 0 1																																													
4																																																			

Procedure 2-8: Press 'SEL'  (begin to edit data)	<table border="1"> <tr> <td></td> <td>1</td> <td>2</td> <td>3</td> <td>4</td> <td>5</td> <td>6</td> <td>7</td> <td>8</td> <td>Column</td> </tr> <tr> <td>Line 1</td> <td></td> <td></td> <td>1</td> <td></td> <td></td> <td></td> <td></td> <td></td> <td></td> </tr> <tr> <td>2</td> <td><u>1</u></td> <td> </td> <td></td> <td></td> <td></td> <td></td> <td></td> <td></td> <td></td> </tr> <tr> <td>3</td> <td></td> <td> </td> <td>3 3 . 3 3</td> <td>S e c</td> <td> </td> <td>T 0 1</td> <td></td> <td></td> <td></td> </tr> <tr> <td>4</td> <td></td> <td> </td> <td></td> <td></td> <td></td> <td></td> <td></td> <td></td> <td></td> </tr> </table>		1	2	3	4	5	6	7	8	Column	Line 1			1							2	<u>1</u>									3			3 3 . 3 3	S e c		T 0 1				4									
	1	2	3	4	5	6	7	8	Column																																										
Line 1			1																																																
2	<u>1</u>																																																		
3			3 3 . 3 3	S e c		T 0 1																																													
4																																																			

Procedure 2-9: Press '↑'  (Press 'SEL' + '↑/↓' to change '1' to '2')	<table border="1"> <tr> <td></td> <td>1</td> <td>2</td> <td>3</td> <td>4</td> <td>5</td> <td>6</td> <td>7</td> <td>8</td> <td>Column</td> </tr> <tr> <td>Line 1</td> <td></td> <td></td> <td>1</td> <td></td> <td></td> <td></td> <td></td> <td></td> <td></td> </tr> <tr> <td>2</td> <td><u>2</u></td> <td> </td> <td></td> <td></td> <td></td> <td></td> <td></td> <td></td> <td></td> </tr> <tr> <td>3</td> <td></td> <td> </td> <td>3 3 . 3 3</td> <td>S e c</td> <td> </td> <td>T 0 1</td> <td></td> <td></td> <td></td> </tr> <tr> <td>4</td> <td></td> <td> </td> <td></td> <td></td> <td></td> <td></td> <td></td> <td></td> <td></td> </tr> </table>		1	2	3	4	5	6	7	8	Column	Line 1			1							2	<u>2</u>									3			3 3 . 3 3	S e c		T 0 1				4									
	1	2	3	4	5	6	7	8	Column																																										
Line 1			1																																																
2	<u>2</u>																																																		
3			3 3 . 3 3	S e c		T 0 1																																													
4																																																			

Procedure 2-10: Press 'OK'  (save the input data)	<table border="1"> <tr> <td></td> <td>1</td> <td>2</td> <td>3</td> <td>4</td> <td>5</td> <td>6</td> <td>7</td> <td>8</td> <td>Column</td> </tr> <tr> <td>Line 1</td> <td></td> <td></td> <td>1</td> <td></td> <td></td> <td></td> <td></td> <td></td> <td></td> </tr> <tr> <td>2</td> <td>2</td> <td> </td> <td></td> <td></td> <td></td> <td></td> <td></td> <td></td> <td></td> </tr> <tr> <td>3</td> <td></td> <td> </td> <td>3 3 . 3 3</td> <td>S e c</td> <td> </td> <td>T 0 1</td> <td></td> <td></td> <td></td> </tr> <tr> <td>4</td> <td></td> <td> </td> <td></td> <td></td> <td></td> <td></td> <td></td> <td></td> <td></td> </tr> </table>		1	2	3	4	5	6	7	8	Column	Line 1			1							2	2									3			3 3 . 3 3	S e c		T 0 1				4									
	1	2	3	4	5	6	7	8	Column																																										
Line 1			1																																																
2	2																																																		
3			3 3 . 3 3	S e c		T 0 1																																													
4																																																			

Procedure 2-11: Press '↑'	<table border="1"> <tr> <td></td> <td>1</td> <td>2</td> <td>3</td> <td>4</td> <td>5</td> <td>6</td> <td>7</td> <td>8</td> <td>Column</td> </tr> <tr> <td>Line 1</td> <td></td> <td></td> <td><u>1</u></td> <td></td> <td></td> <td></td> <td></td> <td></td> <td></td> </tr> </table>		1	2	3	4	5	6	7	8	Column	Line 1			<u>1</u>						
	1	2	3	4	5	6	7	8	Column												
Line 1			<u>1</u>																		

(move the cursor to '1' position)	2	2							
	3			3	3	.	3	3	S e c   T 0 1
	4								

Procedure 2-12: Press 'SEL'  (begin to edit data)	1	2	3	4	5	6	7	8	Column
	Line 1		1						
	2	2							
	3			3	3	.	3	3	S e c   T 0 1
4									

2-13: Press '↑' for 3 times  (Press 'SEL' and followed by '↑ ↓' to change 1 to 4)	1	2	3	4	5	6	7	8	Column
	Line 1		4						
	2	2							
	3			3	3	.	3	3	S e c   T 0 1
4	L o w								

Procedure 2-14: Press 'OK'  (save input data)	1	2	3	4	5	6	7	8	Column
	Line 1		4						
	2	2							
	3			3	3	.	3	3	S e c   T 0 1
4	L o w								

Procedure 2-15: Press '↓' for 3 times  (this step leads to editing the action relay)	1	2	3	4	5	6	7	8	Column
	Line 1		4						
	2	2							
	3			3	3	.	3	3	S e c   T 0 1
4	L o w								

② Edit action program and preset the action relay

Procedure 2-16: Press '→' 2 times, Press 'SEL'  (Begin to modify )	1	2	3	4	5	6	7	8	Column
	Line 1		4						
	2	2							
	3			3	3	.	3	3	S e c   T 0 1
4	L o w								

Procedure 2-16A: Press 'SEL'  (Begin to modify )	1	2	3	4	5	6	7	8	Column
	Line 1		4						
	2	2							
3			3	3	.	3	3	S e c   T 0 1	

	4 I 0 1 ↓	J
--	-----------	---

Repeat the step 2-16A, the following screen will be shown in turn:

Procedure 2-16B: Press 'SEL'	<table border="1" style="width: 100%; border-collapse: collapse;"> <tr> <td style="width: 10%;"></td> <td style="width: 10%; text-align: center;">1</td> <td style="width: 10%; text-align: center;">2</td> <td style="width: 10%; text-align: center;">3</td> <td style="width: 10%; text-align: center;">4</td> <td style="width: 10%; text-align: center;">5</td> <td style="width: 10%; text-align: center;">6</td> <td style="width: 10%; text-align: center;">7</td> <td style="width: 10%; text-align: center;">8</td> <td style="width: 10%;"></td> </tr> <tr> <td>Line 1</td> <td></td> <td></td> <td></td> <td style="text-align: center;">4</td> <td></td> <td></td> <td></td> <td></td> <td>Column</td> </tr> <tr> <td>2</td> <td></td> <td style="text-align: center;">2</td> <td></td> <td></td> <td></td> <td></td> <td></td> <td></td> <td></td> </tr> <tr> <td>3</td> <td></td> <td></td> <td></td> <td style="text-align: center;">3</td> <td style="text-align: center;">3</td> <td style="text-align: center;">.</td> <td style="text-align: center;">3</td> <td style="text-align: center;">3</td> <td style="text-align: center;">S e c</td> <td style="text-align: center;">T 0 1</td> </tr> <tr> <td>4</td> <td></td> <td style="text-align: center;">i</td> <td style="text-align: center;">0</td> <td style="text-align: center;">1</td> <td></td> <td></td> <td></td> <td></td> <td></td> </tr> </table>		1	2	3	4	5	6	7	8		Line 1				4					Column	2		2								3				3	3	.	3	3	S e c	T 0 1	4		i	0	1					
	1	2	3	4	5	6	7	8																																												
Line 1				4					Column																																											
2		2																																																		
3				3	3	.	3	3	S e c	T 0 1																																										
4		i	0	1																																																

Procedure 2-16C: Press 'SEL'	<table border="1" style="width: 100%; border-collapse: collapse;"> <tr> <td style="width: 10%;"></td> <td style="width: 10%; text-align: center;">1</td> <td style="width: 10%; text-align: center;">2</td> <td style="width: 10%; text-align: center;">3</td> <td style="width: 10%; text-align: center;">4</td> <td style="width: 10%; text-align: center;">5</td> <td style="width: 10%; text-align: center;">6</td> <td style="width: 10%; text-align: center;">7</td> <td style="width: 10%; text-align: center;">8</td> <td style="width: 10%;"></td> </tr> <tr> <td>Line 1</td> <td></td> <td></td> <td></td> <td style="text-align: center;">4</td> <td></td> <td></td> <td></td> <td></td> <td>Column</td> </tr> <tr> <td>2</td> <td></td> <td style="text-align: center;">2</td> <td></td> <td></td> <td></td> <td></td> <td></td> <td></td> <td></td> </tr> <tr> <td>3</td> <td></td> <td></td> <td></td> <td style="text-align: center;">3</td> <td style="text-align: center;">3</td> <td style="text-align: center;">.</td> <td style="text-align: center;">3</td> <td style="text-align: center;">3</td> <td style="text-align: center;">S e c</td> <td style="text-align: center;">T 0 1</td> </tr> <tr> <td>4</td> <td></td> <td style="text-align: center;">L</td> <td style="text-align: center;">o</td> <td style="text-align: center;">w</td> <td></td> <td></td> <td></td> <td></td> <td></td> </tr> </table>		1	2	3	4	5	6	7	8		Line 1				4					Column	2		2								3				3	3	.	3	3	S e c	T 0 1	4		L	o	w					
	1	2	3	4	5	6	7	8																																												
Line 1				4					Column																																											
2		2																																																		
3				3	3	.	3	3	S e c	T 0 1																																										
4		L	o	w																																																

Next to step 2-16A, then '↑', the following screen will be shown.

Procedure 2-17: Press '↑' for 5 times  (Press 'SEL' + '↑/↓' to change I to M)	<table border="1" style="width: 100%; border-collapse: collapse;"> <tr> <td style="width: 10%;"></td> <td style="width: 10%; text-align: center;">1</td> <td style="width: 10%; text-align: center;">2</td> <td style="width: 10%; text-align: center;">3</td> <td style="width: 10%; text-align: center;">4</td> <td style="width: 10%; text-align: center;">5</td> <td style="width: 10%; text-align: center;">6</td> <td style="width: 10%; text-align: center;">7</td> <td style="width: 10%; text-align: center;">8</td> <td style="width: 10%;"></td> </tr> <tr> <td>Line 1</td> <td></td> <td></td> <td></td> <td style="text-align: center;">4</td> <td></td> <td></td> <td></td> <td></td> <td>Column</td> </tr> <tr> <td>2</td> <td></td> <td style="text-align: center;">2</td> <td></td> <td></td> <td></td> <td></td> <td></td> <td></td> <td></td> </tr> <tr> <td>3</td> <td></td> <td></td> <td></td> <td style="text-align: center;">3</td> <td style="text-align: center;">3</td> <td style="text-align: center;">.</td> <td style="text-align: center;">3</td> <td style="text-align: center;">3</td> <td style="text-align: center;">S e c</td> <td style="text-align: center;">T 0 1</td> </tr> <tr> <td>4</td> <td></td> <td style="text-align: center;">M</td> <td style="text-align: center;">0</td> <td style="text-align: center;">1</td> <td></td> <td></td> <td></td> <td></td> <td></td> </tr> </table>		1	2	3	4	5	6	7	8		Line 1				4					Column	2		2								3				3	3	.	3	3	S e c	T 0 1	4		M	0	1					
	1	2	3	4	5	6	7	8																																												
Line 1				4					Column																																											
2		2																																																		
3				3	3	.	3	3	S e c	T 0 1																																										
4		M	0	1																																																

Procedure 2-18: Press '→' 2 times  (Press 'SEL' + '← →' to move the cursor to digital location)	<table border="1" style="width: 100%; border-collapse: collapse;"> <tr> <td style="width: 10%;"></td> <td style="width: 10%; text-align: center;">1</td> <td style="width: 10%; text-align: center;">2</td> <td style="width: 10%; text-align: center;">3</td> <td style="width: 10%; text-align: center;">4</td> <td style="width: 10%; text-align: center;">5</td> <td style="width: 10%; text-align: center;">6</td> <td style="width: 10%; text-align: center;">7</td> <td style="width: 10%; text-align: center;">8</td> <td style="width: 10%;"></td> </tr> <tr> <td>Line 1</td> <td></td> <td></td> <td></td> <td style="text-align: center;">4</td> <td></td> <td></td> <td></td> <td></td> <td>Column</td> </tr> <tr> <td>2</td> <td></td> <td style="text-align: center;">2</td> <td></td> <td></td> <td></td> <td></td> <td></td> <td></td> <td></td> </tr> <tr> <td>3</td> <td></td> <td></td> <td></td> <td style="text-align: center;">3</td> <td style="text-align: center;">3</td> <td style="text-align: center;">.</td> <td style="text-align: center;">3</td> <td style="text-align: center;">3</td> <td style="text-align: center;">S e c</td> <td style="text-align: center;">T 0 1</td> </tr> <tr> <td>4</td> <td></td> <td style="text-align: center;">M</td> <td style="text-align: center;">0</td> <td style="text-align: center;">1</td> <td></td> <td></td> <td></td> <td></td> <td></td> </tr> </table>		1	2	3	4	5	6	7	8		Line 1				4					Column	2		2								3				3	3	.	3	3	S e c	T 0 1	4		M	0	1					
	1	2	3	4	5	6	7	8																																												
Line 1				4					Column																																											
2		2																																																		
3				3	3	.	3	3	S e c	T 0 1																																										
4		M	0	1																																																

Procedure 2-19: Press '↑' for 3 times  (Press 'SEL' + '↑ ↓' to change '1' to '4')	<table border="1" style="width: 100%; border-collapse: collapse;"> <tr> <td style="width: 10%;"></td> <td style="width: 10%; text-align: center;">1</td> <td style="width: 10%; text-align: center;">2</td> <td style="width: 10%; text-align: center;">3</td> <td style="width: 10%; text-align: center;">4</td> <td style="width: 10%; text-align: center;">5</td> <td style="width: 10%; text-align: center;">6</td> <td style="width: 10%; text-align: center;">7</td> <td style="width: 10%; text-align: center;">8</td> <td style="width: 10%;"></td> </tr> <tr> <td>Line 1</td> <td></td> <td></td> <td></td> <td style="text-align: center;">4</td> <td></td> <td></td> <td></td> <td></td> <td>Column</td> </tr> <tr> <td>2</td> <td></td> <td style="text-align: center;">2</td> <td></td> <td></td> <td></td> <td></td> <td></td> <td></td> <td></td> </tr> <tr> <td>3</td> <td></td> <td></td> <td></td> <td style="text-align: center;">3</td> <td style="text-align: center;">3</td> <td style="text-align: center;">.</td> <td style="text-align: center;">3</td> <td style="text-align: center;">3</td> <td style="text-align: center;">S e c</td> <td style="text-align: center;">T 0 1</td> </tr> <tr> <td>4</td> <td></td> <td style="text-align: center;">M</td> <td style="text-align: center;">0</td> <td style="text-align: center;">4</td> <td></td> <td></td> <td></td> <td></td> <td></td> </tr> </table>		1	2	3	4	5	6	7	8		Line 1				4					Column	2		2								3				3	3	.	3	3	S e c	T 0 1	4		M	0	4					
	1	2	3	4	5	6	7	8																																												
Line 1				4					Column																																											
2		2																																																		
3				3	3	.	3	3	S e c	T 0 1																																										
4		M	0	4																																																

Procedure 2-20: Press 'OK'  (save the input data)	<table border="1" style="width: 100%; border-collapse: collapse;"> <tr> <td style="width: 10%;"></td> <td style="width: 10%; text-align: center;">1</td> <td style="width: 10%; text-align: center;">2</td> <td style="width: 10%; text-align: center;">3</td> <td style="width: 10%; text-align: center;">4</td> <td style="width: 10%; text-align: center;">5</td> <td style="width: 10%; text-align: center;">6</td> <td style="width: 10%; text-align: center;">7</td> <td style="width: 10%; text-align: center;">8</td> <td style="width: 10%;"></td> </tr> <tr> <td>Line 1</td> <td></td> <td></td> <td></td> <td style="text-align: center;">4</td> <td></td> <td></td> <td></td> <td></td> <td>Column</td> </tr> <tr> <td>2</td> <td></td> <td style="text-align: center;">2</td> <td></td> <td></td> <td></td> <td></td> <td></td> <td></td> <td></td> </tr> <tr> <td>3</td> <td></td> <td></td> <td></td> <td style="text-align: center;">3</td> <td style="text-align: center;">3</td> <td style="text-align: center;">.</td> <td style="text-align: center;">3</td> <td style="text-align: center;">3</td> <td style="text-align: center;">S e c</td> <td style="text-align: center;">T 0 1</td> </tr> <tr> <td>4</td> <td></td> <td style="text-align: center;">M</td> <td style="text-align: center;">0</td> <td style="text-align: center;">4</td> <td></td> <td></td> <td></td> <td></td> <td></td> </tr> </table>		1	2	3	4	5	6	7	8		Line 1				4					Column	2		2								3				3	3	.	3	3	S e c	T 0 1	4		M	0	4					
	1	2	3	4	5	6	7	8																																												
Line 1				4					Column																																											
2		2																																																		
3				3	3	.	3	3	S e c	T 0 1																																										
4		M	0	4																																																

Procedure 2-21: Press '↑'  (Move the cursor to preset	<table border="1" style="width: 100%; border-collapse: collapse;"> <tr> <td style="width: 10%;"></td> <td style="width: 10%; text-align: center;">1</td> <td style="width: 10%; text-align: center;">2</td> <td style="width: 10%; text-align: center;">3</td> <td style="width: 10%; text-align: center;">4</td> <td style="width: 10%; text-align: center;">5</td> <td style="width: 10%; text-align: center;">6</td> <td style="width: 10%; text-align: center;">7</td> <td style="width: 10%; text-align: center;">8</td> <td style="width: 10%;"></td> </tr> <tr> <td>Line 1</td> <td></td> <td></td> <td></td> <td style="text-align: center;">4</td> <td></td> <td></td> <td></td> <td></td> <td>Column</td> </tr> <tr> <td>2</td> <td></td> <td style="text-align: center;">2</td> <td></td> <td></td> <td></td> <td></td> <td></td> <td></td> <td></td> </tr> <tr> <td>3</td> <td></td> <td></td> <td></td> <td style="text-align: center;">3</td> <td style="text-align: center;">3</td> <td style="text-align: center;">.</td> <td style="text-align: center;">3</td> <td style="text-align: center;">3</td> <td style="text-align: center;">S e c</td> <td style="text-align: center;">T 0 1</td> </tr> </table>		1	2	3	4	5	6	7	8		Line 1				4					Column	2		2								3				3	3	.	3	3	S e c	T 0 1
	1	2	3	4	5	6	7	8																																		
Line 1				4					Column																																	
2		2																																								
3				3	3	.	3	3	S e c	T 0 1																																



action value area to repeat the step 2-1)	4 M 0 4 ↓	↓
--	-----------	---

Procedure 2-22: Press '↑'  (Move the cursor to position '2' to repeat the 2-8)	<table border="1"> <tr> <td></td> <td>1</td> <td>2:3</td> <td>4:5</td> <td>6:7:8</td> <td>Column</td> </tr> <tr> <td>Line 1</td> <td></td> <td>4</td> <td></td> <td></td> <td></td> </tr> <tr> <td>2</td> <td>2</td> <td> </td> <td></td> <td></td> <td> </td> </tr> <tr> <td>3</td> <td></td> <td> </td> <td>3 3 . 3 3 S e c</td> <td> </td> <td>T 0 1</td> </tr> <tr> <td>4</td> <td>M 0 4 ↓</td> <td></td> <td></td> <td></td> <td>↓</td> </tr> </table>		1	2:3	4:5	6:7:8	Column	Line 1		4				2	2					3			3 3 . 3 3 S e c		T 0 1	4	M 0 4 ↓				↓
	1	2:3	4:5	6:7:8	Column																										
Line 1		4																													
2	2																														
3			3 3 . 3 3 S e c		T 0 1																										
4	M 0 4 ↓				↓																										

**The detail operation of modify the analogue comparator Ax, Ay:**

	<table border="1"> <tr> <td></td> <td>1</td> <td>2:3</td> <td>4:5</td> <td>6:7:8</td> <td>column</td> </tr> <tr> <td>Line 1</td> <td></td> <td>1</td> <td></td> <td></td> <td></td> </tr> <tr> <td>2</td> <td></td> <td> </td> <td>A 0 1 V</td> <td> </td> <td></td> </tr> <tr> <td>3</td> <td></td> <td> </td> <td>A 0 2 V</td> <td> </td> <td>G 0 1</td> </tr> <tr> <td>4</td> <td></td> <td>↓</td> <td>0 0 . 0 0 V</td> <td>↓</td> <td></td> </tr> </table>		1	2:3	4:5	6:7:8	column	Line 1		1				2			A 0 1 V			3			A 0 2 V		G 0 1	4		↓	0 0 . 0 0 V	↓	
	1	2:3	4:5	6:7:8	column																										
Line 1		1																													
2			A 0 1 V																												
3			A 0 2 V		G 0 1																										
4		↓	0 0 . 0 0 V	↓																											

step 2-23: Press '←', press 'SEL'  (press '↑ ↓', Select A01-A08 )	<table border="1"> <tr> <td></td> <td>1</td> <td>2:3</td> <td>4:5</td> <td>6:7:8</td> <td>column</td> </tr> <tr> <td>line 1</td> <td></td> <td>1</td> <td></td> <td></td> <td></td> </tr> <tr> <td>2</td> <td></td> <td> </td> <td>A 0 1 V</td> <td> </td> <td></td> </tr> <tr> <td>3</td> <td></td> <td> </td> <td>A 0 2 V</td> <td> </td> <td>G 0 1</td> </tr> <tr> <td>4</td> <td></td> <td>↓</td> <td>0 0 . 0 0 V</td> <td>↓</td> <td></td> </tr> </table>		1	2:3	4:5	6:7:8	column	line 1		1				2			A 0 1 V			3			A 0 2 V		G 0 1	4		↓	0 0 . 0 0 V	↓	
	1	2:3	4:5	6:7:8	column																										
line 1		1																													
2			A 0 1 V																												
3			A 0 2 V		G 0 1																										
4		↓	0 0 . 0 0 V	↓																											

Step 2-24: Press '←', Press 'SEL' (press 'SEL' Select A02 – T01 – C01–AT01–AQ01–DR01– AS01– MD01–PI01–MX01– AR01–00.00– V01–A01)	<table border="1"> <tr> <td></td> <td>1</td> <td>2:3</td> <td>4:5</td> <td>6:7:8</td> <td>column</td> </tr> <tr> <td>line 1</td> <td></td> <td>1</td> <td></td> <td></td> <td></td> </tr> <tr> <td>2</td> <td></td> <td> </td> <td>A 0 1 V</td> <td> </td> <td></td> </tr> <tr> <td>3</td> <td></td> <td> </td> <td>T 0 1 V</td> <td> </td> <td>G 0 1</td> </tr> <tr> <td>4</td> <td></td> <td>↓</td> <td>0 0 . 0 0 V</td> <td>↓</td> <td></td> </tr> </table>		1	2:3	4:5	6:7:8	column	line 1		1				2			A 0 1 V			3			T 0 1 V		G 0 1	4		↓	0 0 . 0 0 V	↓	
	1	2:3	4:5	6:7:8	column																										
line 1		1																													
2			A 0 1 V																												
3			T 0 1 V		G 0 1																										
4		↓	0 0 . 0 0 V	↓																											

Step 2-25: Press '→', press '↑'  (Select T01~T1F, C01~C1F, A01~A08, V01~V08...)	<table border="1"> <tr> <td></td> <td>1</td> <td>2:3</td> <td>4:5</td> <td>6:7:8</td> <td>column</td> </tr> <tr> <td>line 1</td> <td></td> <td>1</td> <td></td> <td></td> <td></td> </tr> <tr> <td>2</td> <td></td> <td> </td> <td>A 0 1 V</td> <td> </td> <td></td> </tr> <tr> <td>3</td> <td></td> <td> </td> <td>T 0 2 V</td> <td> </td> <td>G 0 1</td> </tr> <tr> <td>4</td> <td></td> <td>↓</td> <td>0 0 . 0 0 V</td> <td>↓</td> <td></td> </tr> </table>		1	2:3	4:5	6:7:8	column	line 1		1				2			A 0 1 V			3			T 0 2 V		G 0 1	4		↓	0 0 . 0 0 V	↓	
	1	2:3	4:5	6:7:8	column																										
line 1		1																													
2			A 0 1 V																												
3			T 0 2 V		G 0 1																										
4		↓	0 0 . 0 0 V	↓																											

Step 2-26: Press 'OK'  Save the present data	<table border="1"> <tr> <td></td> <td>1</td> <td>2:3</td> <td>4:5</td> <td>6:7:8</td> <td>column</td> </tr> <tr> <td>line 1</td> <td></td> <td>1</td> <td></td> <td></td> <td></td> </tr> <tr> <td>2</td> <td></td> <td> </td> <td>A 0 1 V</td> <td> </td> <td></td> </tr> <tr> <td>3</td> <td></td> <td> </td> <td>T 0 2 V</td> <td> </td> <td>G 0 1</td> </tr> <tr> <td>4</td> <td></td> <td>↓</td> <td>0 0 . 0 0 V</td> <td>↓</td> <td></td> </tr> </table>		1	2:3	4:5	6:7:8	column	line 1		1				2			A 0 1 V			3			T 0 2 V		G 0 1	4		↓	0 0 . 0 0 V	↓	
	1	2:3	4:5	6:7:8	column																										
line 1		1																													
2			A 0 1 V																												
3			T 0 2 V		G 0 1																										
4		↓	0 0 . 0 0 V	↓																											

**Continue to input Function Block**

Next Function Block

	:1	:2:3	:4:5	:6:7:8	Column
Line 1		4			
2	2				
3		3 3 . 3 3 S e c			T 0 1
4	M 0 4				

Procedure 1: Press 'SEL+↑' (Simultaneously)	:1	:2:3	:4:5	:6:7:8	Column
Line 1		1			
2	1				
3		0 0 . 0 0 S e c			T 0 2
4					

**Last Function Block**

Line 1	:1	:2:3	:4:5	:6:7:8	Column
2		4			
3	2				
4		3 3 . 3 3 S e c			T 0 1
	M 0 4				

Procedure : Press 'SEL+↓' (Simultaneously)	:1	:2:3	:4:5	:6:7:8	Column
v 1		1			
2	1				
3		0 0 . 0 0 S e c			T 1 F
4					

**Delete Function Block**

Procedure:	1	2	3	4	5	6	7	8	Column				
Press 'SEL+DEL' (Simultaneously)	Line 1			4									
	2	2											
	3	C	L	E	A	R		B	L	O	C	K	!
('ESC': Cancel ; 'OK': Execute)	4	E	S	C	?			O	K	?			

**Back to Main Menu:**

Press 'ESC'	1	2	3	4	5	6	7	8	Column	
Line 1	L	A	D	D	E	R				
2	>	F	U	N	.	B	L	O	C	K
3	P	A	R	A	M	E	T	E	R	
4	R	U	N							

**Change Function Block Category:**

	1	2	3	4	5	6	7	8	Column					
Line 1				4										
2	2													
3			3	3	.	3	3	S	e	c		T	0	1
4	M	0	4											

Move the cursor to change to T, C, R, G, H, L, P, S, AS, MD,

Step 1: Press 'SEL'	1	2	3	4	5	6	7	8	Column					
Line 1				1										
2	L	o	w											
3					0	0	0	0	0	0		C	0	1
4	L	o	w											

Step 2: Press 'SEL'	1	2	3	4	5	6	7	8	Column					
Line 1					S	u	—	S	u					
2	1													
3					0	0	:	0	0			R	0	1
4					0	0	:	0	0					

Step3: Press 'SEL'	1	2	3	4	5	6	7	8	Column					
Line 1				1										
2					A	0	1	V						
3					A	0	2	V						
4					0	0	.	0	0	V		G	0	1

Step4:	1	2	3	4	5	6	7	8	Column
--------	---	---	---	---	---	---	---	---	--------

Press 'SEL'	Line 1	1						
	2							
	3						H	0 1
	4							

Step5: Press 'SEL'		1	2:3	4:5	6:7:8	Column
	Line 1	1				
	2	1	I 0 1	I 0 1		
	3		↓	↓		L 0 1
4		W 0 9	W 0 9			

Step 6: Press 'SEL'		1	2:3	4:5	6:7:8	Column
	Line 1	1				
	2	L o w				Q 0 1
	3	L o w	0 0 0 0 0 0			P 0 1
4	L o w	0 0 0 0 0 1				

Step7: Press 'SEL'		1	2:3	4:5	6:7:8	Column
	Line 1	1				
	2	1				
	3	L o w	Q 0 1	Q 0 1		S 0 1
4						

Step 8: Press 'SEL'		1	2:3	4:5	6:7:8	Column
	Line 1					
	2		0 0 0 0 0			N o p
	3		0 0 0 0 0			A S 0 1
4		0 0 0 0 0				

Step 9: Press 'SEL'		1	2:3	4:5	6:7:8	Column
	Line 1					
	2		0 0 0 0 1			N o p
	3		0 0 0 0 1			M D 0 1
4		0 0 0 0 1				

Step 10-A: Press 'SEL'		1	2:3	4:5	6:7:8	Column
	Line 1					
	2		0 0 0 0 0			N o p
	3		0 0 0 0 0			P I 0 1
4		0 0 0 . 0 1			1	

Step 10-B: Press 'SEL + →'		1	2:3	4:5	6:7:8	Column
	Line 1					
	2		0 0 0 0 1			N o p
3		0 0 0 0 . 1			P I 0 1	

	4    ↓    0 0 0 . 0 1    ↓    2	
--	---------------------------------	--

Step 11: Press 'SEL'	<table border="1" style="width: 100%; border-collapse: collapse;"> <thead> <tr> <th style="width: 5%;"></th> <th style="width: 15%;">1</th> <th style="width: 15%;">2:3</th> <th style="width: 15%;">4:5</th> <th style="width: 15%;">6:7:8</th> <th style="width: 10%;">Column</th> </tr> </thead> <tbody> <tr> <td>Line 1</td> <td></td> <td></td> <td>0 0 0 0 0</td> <td></td> <td></td> </tr> <tr> <td>2 L o w</td> <td rowspan="4" style="font-size: 2em; vertical-align: middle;">[</td> <td></td> <td>0 0 0 0 0</td> <td rowspan="4" style="font-size: 2em; vertical-align: middle;">]</td> <td rowspan="4" style="vertical-align: middle;">M <b>X</b> 0 1</td> </tr> <tr> <td>3 L o w</td> <td></td> <td>0 0 0 0 0</td> </tr> <tr> <td>4</td> <td></td> <td>0 0 0 0 0</td> </tr> </tbody> </table>		1	2:3	4:5	6:7:8	Column	Line 1			0 0 0 0 0			2 L o w	[		0 0 0 0 0	]	M <b>X</b> 0 1	3 L o w		0 0 0 0 0	4		0 0 0 0 0
	1	2:3	4:5	6:7:8	Column																				
Line 1			0 0 0 0 0																						
2 L o w	[		0 0 0 0 0	]	M <b>X</b> 0 1																				
3 L o w			0 0 0 0 0																						
4			0 0 0 0 0																						

Step 12-A: Press 'SEL'	<table border="1" style="width: 100%; border-collapse: collapse;"> <thead> <tr> <th style="width: 5%;"></th> <th style="width: 15%;">1</th> <th style="width: 15%;">2:3</th> <th style="width: 15%;">4:5</th> <th style="width: 15%;">6:7:8</th> <th style="width: 10%;">Column</th> </tr> </thead> <tbody> <tr> <td>Line 1</td> <td></td> <td></td> <td>0 0 0 0 0</td> <td></td> <td></td> </tr> <tr> <td>2 L o w</td> <td rowspan="4" style="font-size: 2em; vertical-align: middle;">[</td> <td></td> <td>0 0 0 0 0</td> <td rowspan="4" style="font-size: 2em; vertical-align: middle;">]</td> <td rowspan="4" style="vertical-align: middle;">N o p A <b>R</b> 0 1</td> </tr> <tr> <td>3 L o w</td> <td></td> <td>0 0 0 0 0</td> </tr> <tr> <td>4</td> <td></td> <td>0 1 0 0 0</td> </tr> </tbody> </table>		1	2:3	4:5	6:7:8	Column	Line 1			0 0 0 0 0			2 L o w	[		0 0 0 0 0	]	N o p A <b>R</b> 0 1	3 L o w		0 0 0 0 0	4		0 1 0 0 0
	1	2:3	4:5	6:7:8	Column																				
Line 1			0 0 0 0 0																						
2 L o w	[		0 0 0 0 0	]	N o p A <b>R</b> 0 1																				
3 L o w			0 0 0 0 0																						
4			0 1 0 0 0																						

Step 12-B: Press 'SEL + →'	<table border="1" style="width: 100%; border-collapse: collapse;"> <thead> <tr> <th style="width: 5%;"></th> <th style="width: 15%;">1</th> <th style="width: 15%;">2:3</th> <th style="width: 15%;">4:5</th> <th style="width: 15%;">6:7:8</th> <th style="width: 10%;">Column</th> </tr> </thead> <tbody> <tr> <td>Line 1</td> <td></td> <td></td> <td>0 0 0 0 0</td> <td></td> <td></td> </tr> <tr> <td>2 L o w</td> <td rowspan="4" style="font-size: 2em; vertical-align: middle;">[</td> <td></td> <td>0 0 0 1 0</td> <td rowspan="4" style="font-size: 2em; vertical-align: middle;">]</td> <td rowspan="4" style="vertical-align: middle;">N o p A <b>R</b> 0 1</td> </tr> <tr> <td>3 L o w</td> <td></td> <td>0 1 . 0 0</td> </tr> <tr> <td>4</td> <td></td> <td>0 0 0 0 0</td> </tr> </tbody> </table>		1	2:3	4:5	6:7:8	Column	Line 1			0 0 0 0 0			2 L o w	[		0 0 0 1 0	]	N o p A <b>R</b> 0 1	3 L o w		0 1 . 0 0	4		0 0 0 0 0
	1	2:3	4:5	6:7:8	Column																				
Line 1			0 0 0 0 0																						
2 L o w	[		0 0 0 1 0	]	N o p A <b>R</b> 0 1																				
3 L o w			0 1 . 0 0																						
4			0 0 0 0 0																						

Step 13: Press 'SEL'	<table border="1" style="width: 100%; border-collapse: collapse;"> <thead> <tr> <th style="width: 5%;"></th> <th style="width: 15%;">1</th> <th style="width: 15%;">2:3</th> <th style="width: 15%;">4:5</th> <th style="width: 15%;">6:7:8</th> <th style="width: 10%;">Column</th> </tr> </thead> <tbody> <tr> <td>Line 1</td> <td></td> <td>1</td> <td></td> <td></td> <td></td> </tr> <tr> <td>2</td> <td rowspan="4" style="font-size: 2em; vertical-align: middle;">[</td> <td></td> <td>0 1</td> <td rowspan="4" style="font-size: 2em; vertical-align: middle;">]</td> <td rowspan="4" style="vertical-align: middle;">M <b>U</b> 0 1</td> </tr> <tr> <td>3</td> <td></td> <td>0 0 0 1</td> </tr> <tr> <td>4</td> <td></td> <td>D R 0 1</td> </tr> </tbody> </table>		1	2:3	4:5	6:7:8	Column	Line 1		1				2	[		0 1	]	M <b>U</b> 0 1	3		0 0 0 1	4		D R 0 1
	1	2:3	4:5	6:7:8	Column																				
Line 1		1																							
2	[		0 1	]	M <b>U</b> 0 1																				
3			0 0 0 1																						
4			D R 0 1																						

IMO Precision Controls Limited  
1000 North Circular Road  
Staples Corner  
London NW2 7JP  
United Kingdom

Tel: +44 (0)20 8452 6444  
Fax: +44 (0)20 8450 2274  
Email: [imo@imopc.com](mailto:imo@imopc.com)  
Web: [www.imopc.com](http://www.imopc.com)

IMO Automazione  
Viale A. Volta 127/a  
50131 Firenze  
Italia

Tel: +39 800 783281  
Fax: +39 800 783282  
Email: [info@imopc.it](mailto:info@imopc.it)  
Web: [www.imopc.it](http://www.imopc.it)

IMO Jeambrun Automation SAS  
Centre D'Affaires Rocroy  
30, Rue de Rocroy  
94100 Saint-Maur-Des-Fosses  
France

Tel: +8000 452 6444  
Fax: +8000 452 6445  
Email: [info@imopc.fr](mailto:info@imopc.fr)  
Web: [www.imopc.fr](http://www.imopc.fr)

IMO Canada  
Unit 10, 1 Whitmore Road  
Woodbridge  
Ontario L4L 8G4  
Canada

Tel: +1 905 265 9844  
Fax: +1 905 265 1749  
Email: [imocanada@imopc.com](mailto:imocanada@imopc.com)  
Web: [www.imopc.com](http://www.imopc.com)