

© User Manual

**ANYCUBIC 4MAX PRO**



Dear Customer,

Thank you for choosing **ANYCUBIC** products.

Maybe you are familiar with 3D printing technology or have purchased **ANYCUBIC** printers before, we still highly recommend that you read this manual carefully. The installation techniques and precautions in this manual can help you avoid any unnecessary damage or first time frustration.

**Note: 4Max Pro has multiple color options. The machine in this manual may have a different color from your purchase, please be relax and carry on the assembly and operation according to the manual.**

More information please refer to :

1. <http://www.anycubic.com/>

**ANYCUBIC** website provides software, **tutorials**, models, **after-sale service**, etc.

Please visit the website for technical support and we are likely to answer or solve all the questions for you!

2. Facebook page and Youtube channel links are shown below.



**ANYCUBIC** Website



Facebook page



Youtube channel

Team **ANYCUBIC**

## Safety instruction

Always follow the safety instructions during assembly and usage, to avoid any unnecessary damage to the 3d printer or individual injury.



Please contact our customer service first if you have any issue after receiving the products.



Be cautious when using the scraper. Never direct the scraper towards your hand.



In case of emergency, please immediately cut off the power of **ANYCUBIC** 3D printer and contact the technical support.



**ANYCUBIC** 3D printer includes moving parts that can cause injury.



It is recommended to use protection glasses when cleaning/sanding the printed models to avoid small particles contacting eyes.



Keep the **ANYCUBIC** 3D printer and its accessories out of the reach of children.



Vapors or fumes may be irritating at operating temperature. Always use the **ANYCUBIC** 3D printer in an open and well ventilated area.



**ANYCUBIC** 3D printer must not be exposed to water or rain.



**ANYCUBIC** 3D printer is designed to be used within ambient temperature ranging 8°C-40°C, and humidity ranging 20%-50%. Working outside those limits may result in low quality printing.



Do not disassemble **ANYCUBIC** 3D printer, please contact technical support if you have any question.



# Contents

<b>Technical Specification</b>	1
<b>Packing list</b>	2
<b>Product Overview</b>	3
<b>Menu Directory</b>	5
<b>Unpacking</b>	9
<b>Installation</b>	11
Install filament sensor	12
Install filament holder and filament	13
<b>Leveling</b>	17
Manual Leveling	17
Print test	20
<b>Driver installation</b>	22
<b>Introduction to slicing software</b>	24
Cura installation	24
Manipulate 3D model in Cura	26
Cura settings	27
Print online	33
Print offline	33
<b>Introduction to filament sensor</b>	34
<b>Introduction to nozzle brush</b>	35
<b>Resume from outage</b>	36
<b>Troubleshooting</b>	38

# Technical Specification

---

## Printing

Technology:	FDM (Fused Deposition Modeling)
Build Size:	270mm(L)*205mm(W) * 205mm(H)
Print accuracy:	0.05-0.3 mm
Positioning Accuracy:	X/Y/Z 0.01/0.0125/0.00125mm
Extruder Quantity:	Single
Nozzle Diameter:	0.4 mm
Print Speed:	20~80mm/s (suggested 50mm/s)
Supported Materials:	PLA, ABS, etc

## Temperature

Ambient Operating Temperature:	8°C - 40°C
Operational Extruder Temperature:	max 260°C
Operational Print Bed Temperature:	max 100°C

## Software

Slicer Software:	Cura, Smplyfy3D, Repetier-HOST
Software Input Formats:	.STL, .OBJ, .JPG, PNG
Software Output Formats:	GCode
Connectivity:	Memory card; Data cable(expert users only)

















## Electrical

Input rating:	110V/220V AC, 50/60Hz
---------------	-----------------------

## Physical Dimensions

Printer Dimensions:	454mm*466mm*410mm
Net Weight:	~18.2kg

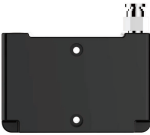
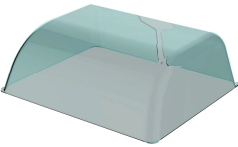
# Packing list

		
	<p>Tool kit 1 unit</p>	<p>M3*16 screw 2PCS</p>
		
<p><b>ANYCUBIC 4MAX PRO</b></p>	<p>Gloves 1 pair</p>	<p>Power cord 1PCS</p>
		
<p>Data cable 1PCS</p>	<p>Spatula 1PCS</p>	<p>Card reader 1PCS</p>
		
<p>Gift filament 1PCS</p>	<p>Filament holder 1 Unit</p>	<p>Extra Nozzle Kit 1PCS</p>
		
<p>Tweezers&amp; Nozzle cleaning needles 1 PCS each</p>	<p>Plier 1 PCS</p>	<p>Memory card 1 PCS</p>
		
<p>Filament sensor 1PCS</p>	<p>Top cover 1 PCS</p>	<p>User manual 1PCS</p>

# Product Overview

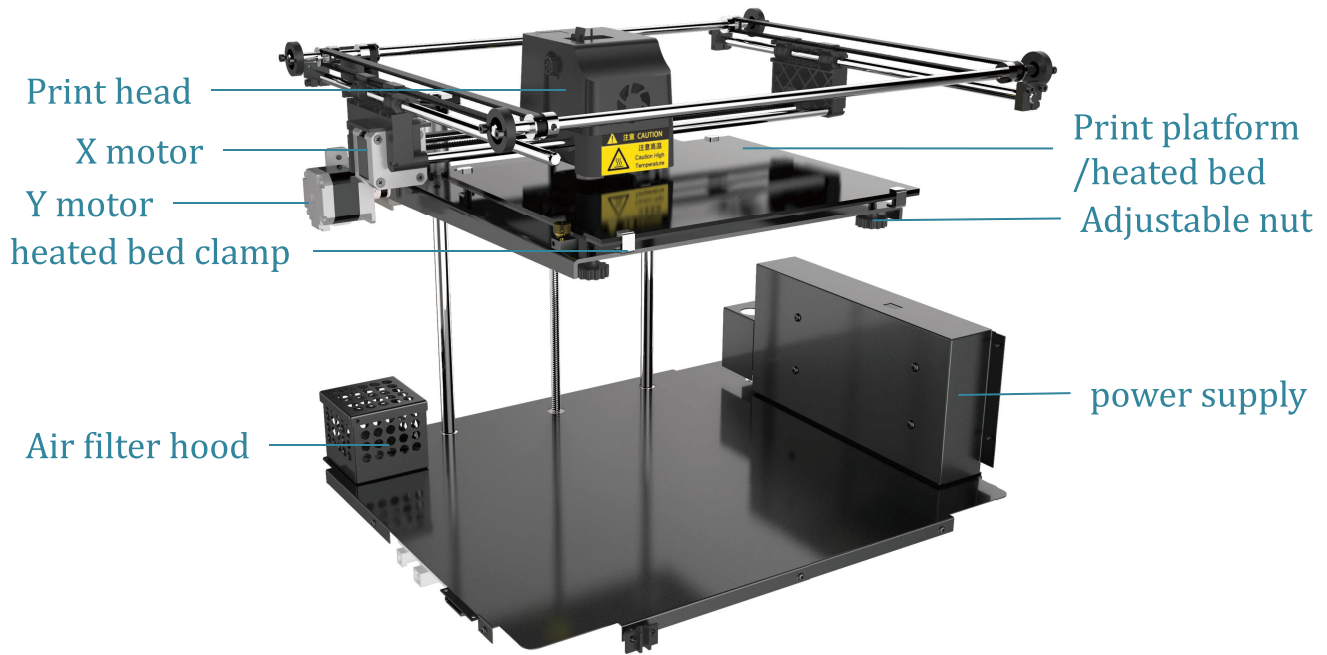

# Product Overview



# Menu Directory

## Home menu

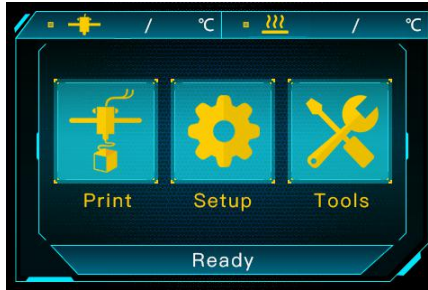

## Print



## Setup

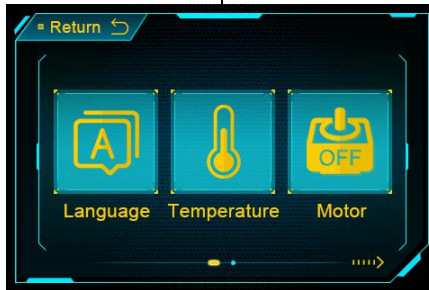

## Tools

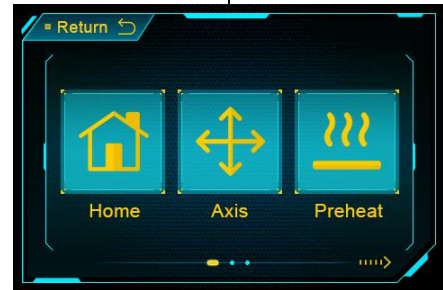

## Setup

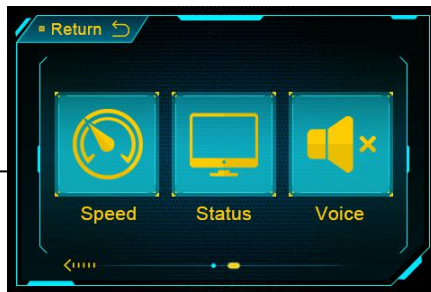

## Tools

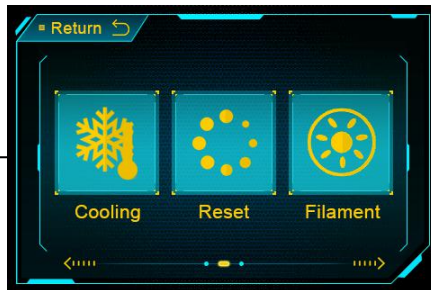

## Tools



# Menu Directory

## Home menu

Nozzle Temp /Target Temp

Heated bed Temp/Target Temp

Enter the print list

Enter the tools list

Enter the setup list

Printer status

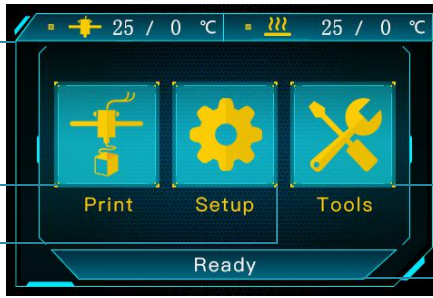

## Print

Return to the home menu

File list

Print the selected files in memory card

Page up

Page down

Refresh the list

Resume form outage (only valid for offline print via memory card)



## Setup

**Language:** Change language (English/Chinese)

**Temperature:**

Reduce nozzle Temp

Raise nozzle Temp

Current nozzle Temp

Click to set nozzle Temp(170-260°C)

Current heated bed Temp

Click to set heated bed Temp(0-100°C)

Reduce heated bed Temp

Raise heated bed Temp

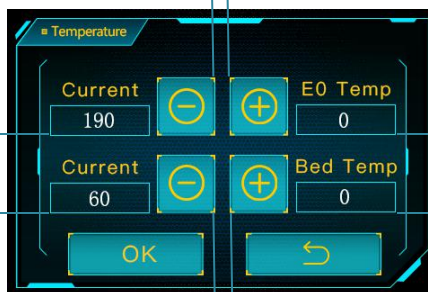

# Menu Directory

**Motor:** Disable all motors (only valid when machine is not printing)

**Speed:**

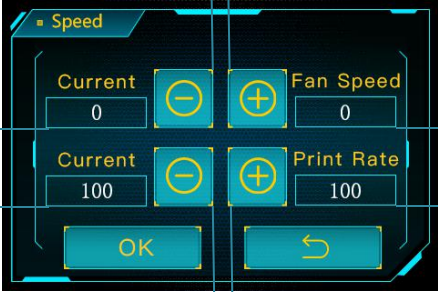
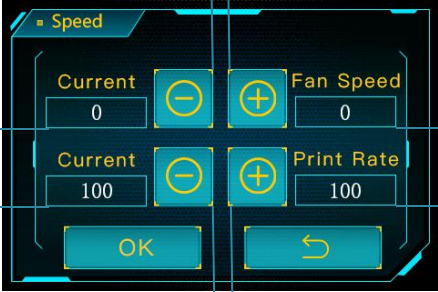
	Decrease fan speed	Increase fan speed	
Current fan speed			Click to set fan speed(0-100%)
Current print rate			Click to set print rate(50-100%)
	Decrease print rate	Increase print rate	





**Status:** (the following with \* is valid only for offline printing , i.e. print from memory card)

Return to previous menu			Auto shut off <input checked="" type="checkbox"/>
Files*			Print Rate
Time			Progress*
Nozzle Temp/Target Temp			Heated bed Temp/Target Temp
Coordinates for X/Y/Z axis			
Pause print*			Stop print*

**Voice:** Turn on/off the screen sound

## Tools

**Home:** (only valid when machine is not printing)

Return to previous menu			
Click to home X			Click to home Y
Click to home Z			Click to home All



# Menu Directory

**Axis:** (only valid when machine is not printing)



Move left/right X axis by 0.1/1.0/10mm

Move forward/backward Y axis by 0.1/1.0/10mm

Move up/down Z axis by 0.1/1.0/10mm

Return

Speed mode for axis move Low/Medium/High

**Preheat:** (only valid when machine is not printing)

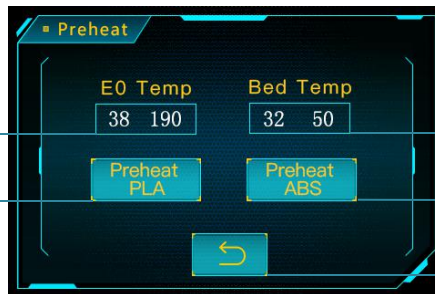

Nozzle Temp/Target Temp

Heated bed Temp/Target Temp

Click to preheat PLA

Click to preheat ABS

Return

**Cooling:** Cut off the power to hot-end and heated bed (only valid when machine is not printing)

**Reset:** Pop up window to decide if reboot the mainboard

**Filament:** (only valid for offline print)



Automatically heating to the setting temperature for filament in

Automatically heating to the setting temperature for filament remove

Stop to filament in/remove

Return

**Help:** Basic description of the Menu

**About:** Information about the product

**Light:** Turn on/off the light

# Unpacking

1. After unpacking, remove all the foams inside the machine chamber.

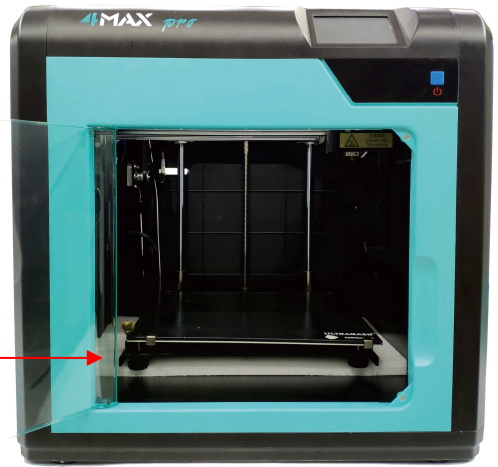

Remove this foam in following steps

2. Cut all the 7 cable ties (numbered in following pictures).

The fastener also needs to be removed.

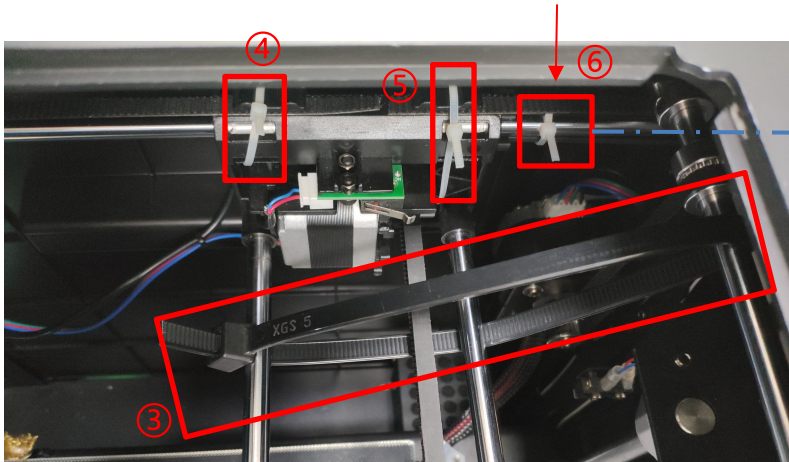

Fastener

Front

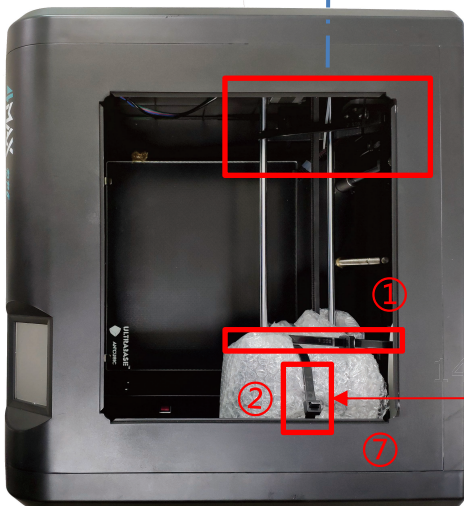

⑦ corresponds to ⑥ on the other side, the fastener on this side also needs to be removed.

Side

# Unpacking

3. Inside the chamber, select the correct voltage mode according to your local voltage ratings (~110V or ~220V). The switch is inside the power supply casing and **220V is default**. Hex keys can be used to move the switch. Finally, double check the wirings and plug in the power cord and power on the printer.

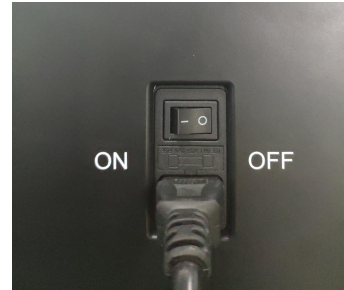
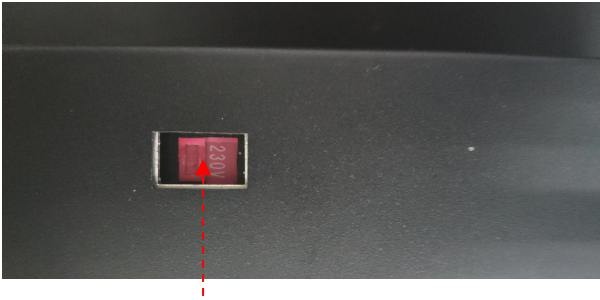

**In some cases, 220V labeled as "230" ,  
110V labeled as "115"**

4. Press the machine switch to turn on the machine.

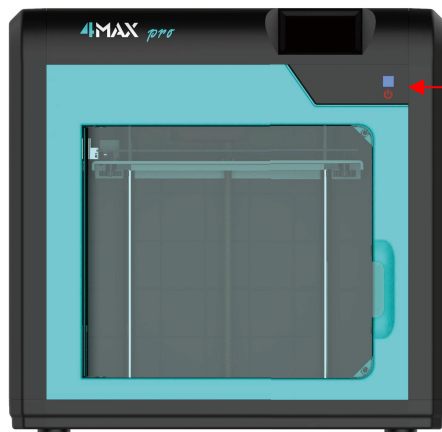

Press the machine switch

5. On Home Menu, click "Tools"-->"Home"-->"Home All". After the platform rises, take out the foam.

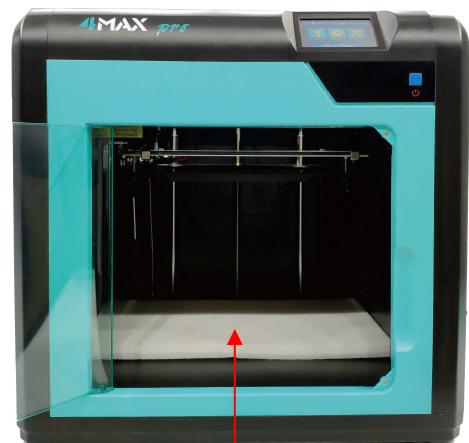
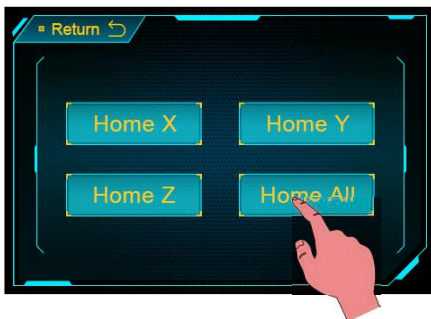

Take out the foam

# Installation

---

1. Be cautious during assembly as some parts may have sharp edges.
2. It is suggested to use a flat desktop and place the parts in an orderly manner for quick assembly.
3. The color of some parts may be different from what in the manual, but the assembly is the same.
4. Firmware has been pre-uploaded to the motherboard. After completing the assembly, please load the filament and level the platform then you could start the first test print.

Please note: every unit of the printer has been inspected and tested for printing. Therefore, in some cases, there might be very small marks left on the print head or on the heated bed. Those will not affect the printing quality and those mean the printer has been tested for the quality. Meanwhile, we provide an extra hot end in case you need to replace it in the future. Thank you very much for your kind understanding.

Team **ANYCUBIC**

# Installation

## 1. Install filament sensor

(1) Insert the filament sensor wire onto the corresponding port of the filament sensor module.



(2) Install filament sensor to the back side of the printer by two M3\*16 screws.

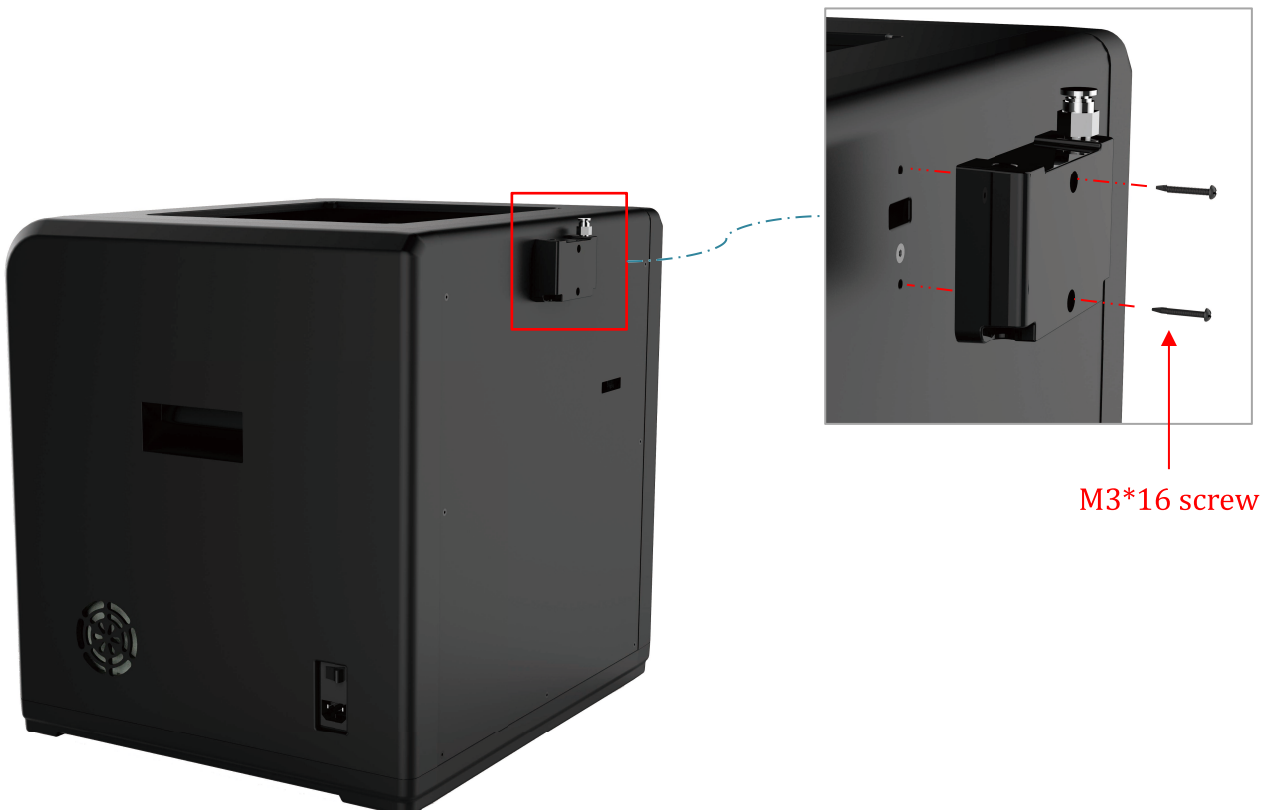

# Installation

## 2. Install filament holder and filament

(1) Place the filament holder on the back.

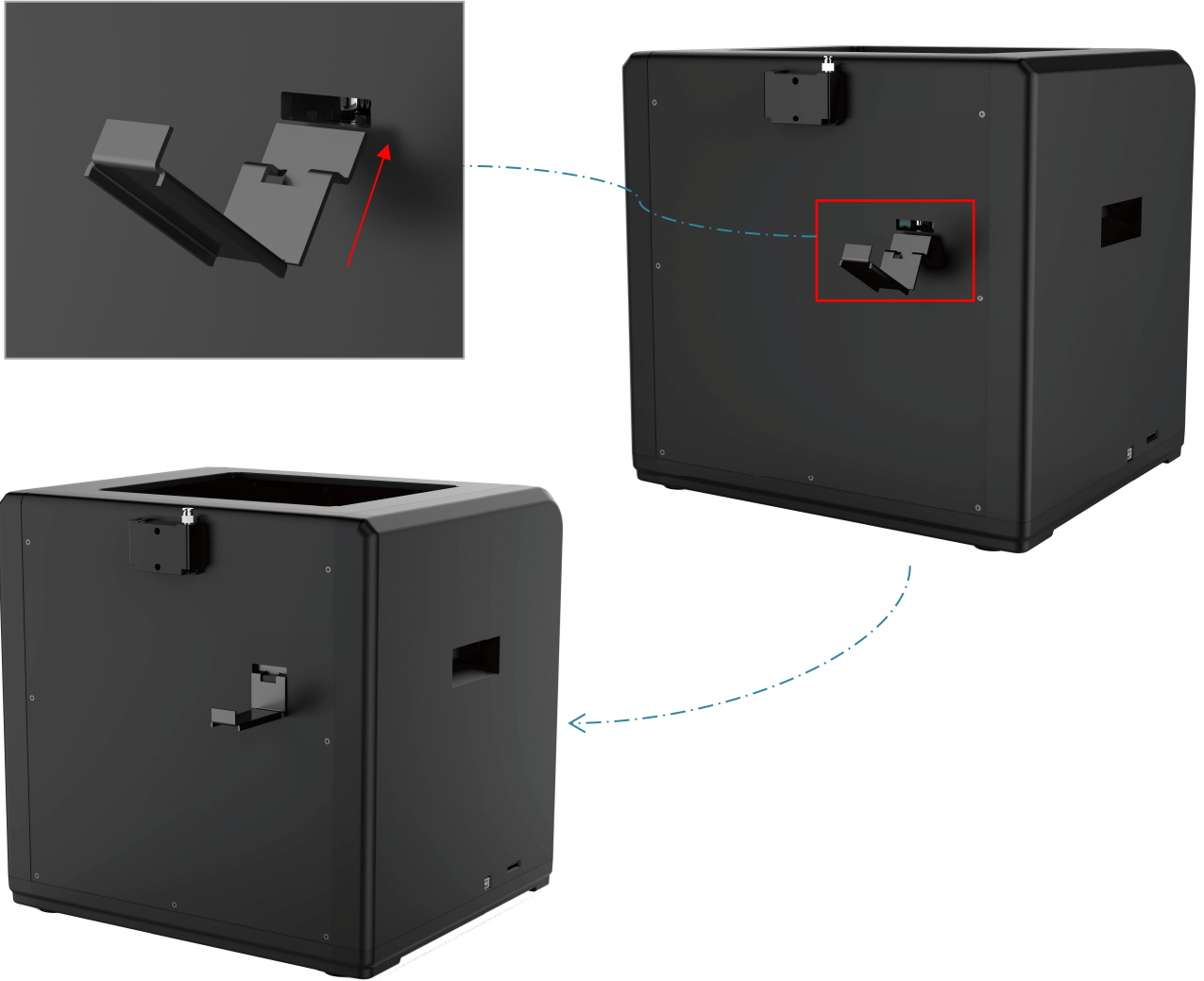

(2) Place the filament on filament holder, note the feeding direction of the spool.

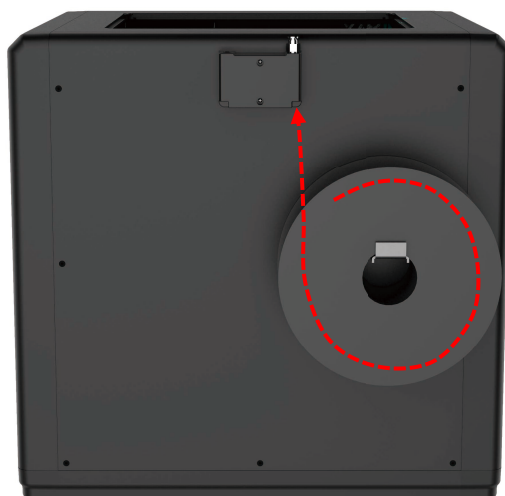



# Installation

## (3) Install filament

- ① Free and straighten the tip of filament, pass it through the filament sensor.  
(For easier passing through, you may need to rotate the filament tip when pass it)



- ② After the filament passing through the Teflon tubing, press the handle on the extruder to insert the filament till the filament reaches down to the end.

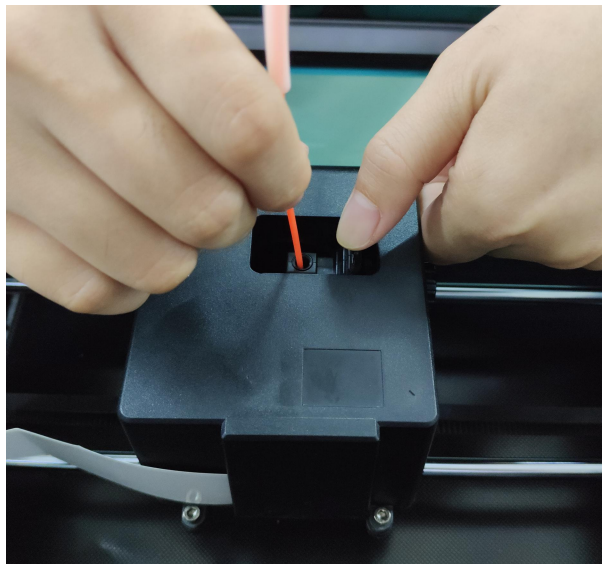

# Installation

- ③ Now, insert the teflon tubing to the extruder. **Insert it well to prevent it from coming off during printing.**

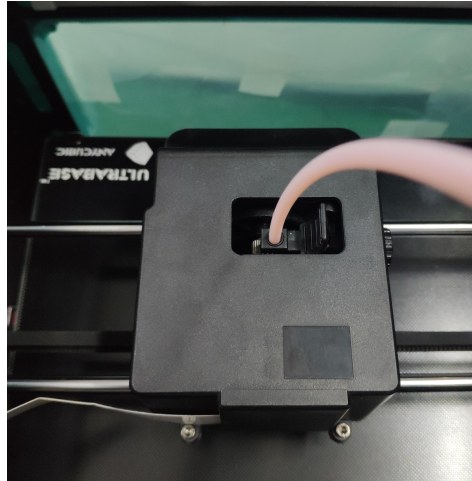

- ④ Click “Tools”→ “Axis” to drop the platform about 50mm.



Click 5 times

- ⑤ Click “Tools”→ “Filament”→ “Filament in”, and click “OK” on the pop-up window to heat the nozzle.

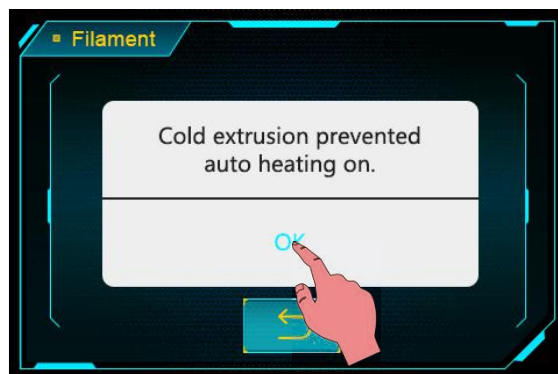



# Installation

(4) When the nozzle reaches to the target temperature (i.e. 230°C), click “Filament in” **again**, the filament would be automatically fed in by the extruder and it would be melted through the nozzle. Now, click “STOP”. You may use tweezers to clean the filament residue on the nozzle tip.

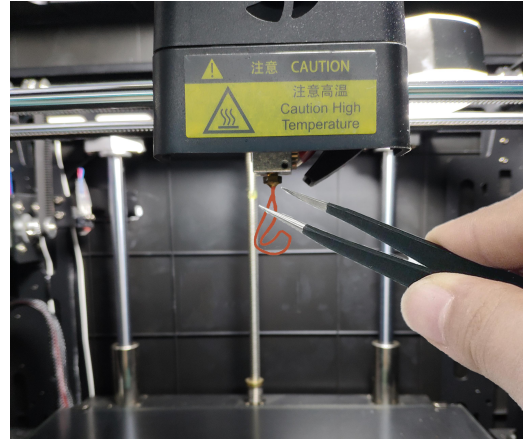

During “Filament in”, the feeding speed maybe much faster than average. The filament may be stopped at the Teflon tubing due to too much pushing. That means the filament is reaching to the nozzle and now please click stop.

Note: During feeding, if the melted filament is not smooth or too thin, please adjust the extrusion force by rotating the knob as shown below.

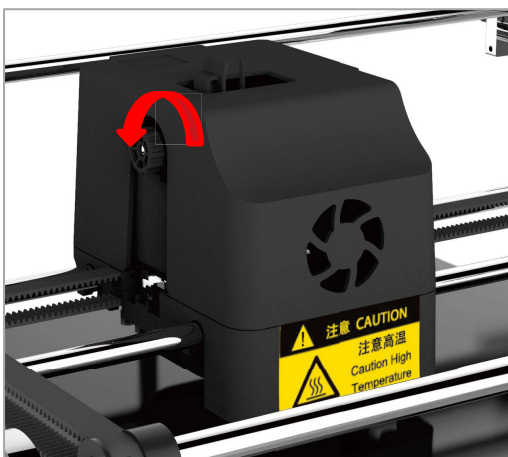

Increase the extrusion force by rotating counterclockwise

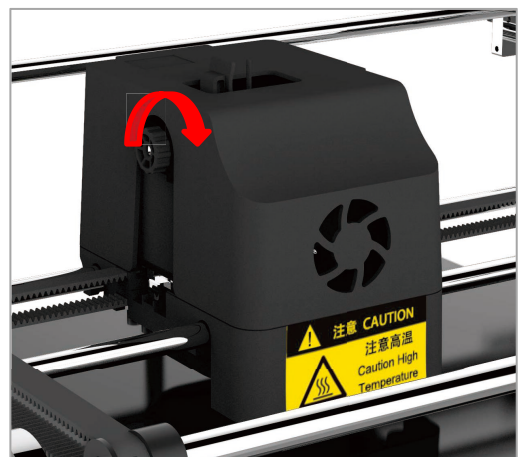

Reduce the extrusion force by rotating clockwise

# Leveling

**It is essential to level the print platform of a 3D printer. Once leveled, it is not necessary to level every time before each prints. Please follow the procedures below:**

## 1. Manual Leveling

**Step 1.** Before leveling, in order to avoid burns from a hot nozzle, **it is highly recommended to cool down first.** Click “Tools” → “Cooling” on the screen, wait the temperature in the highlighted box to drop down to below 60°C.

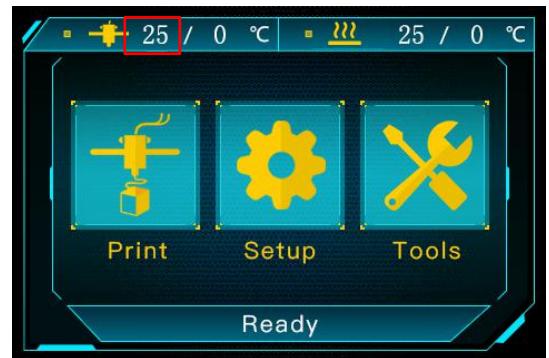
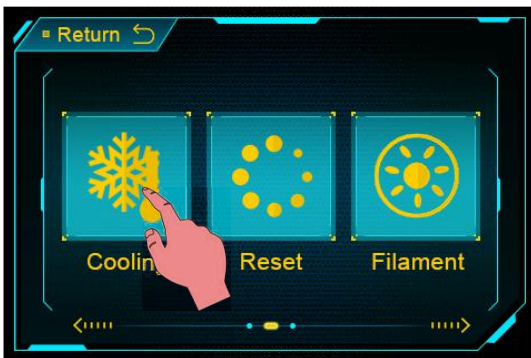

**Step 2.** On Home Menu, click “Tools”-->“Home”-->“Home All”.

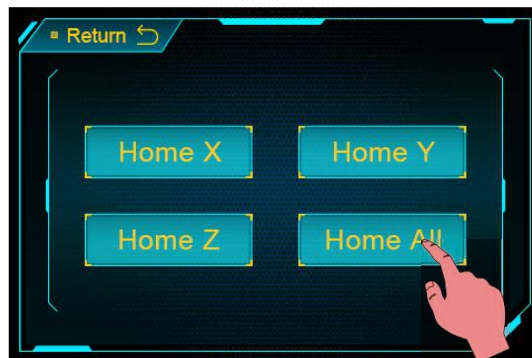

**Step 3.** Return to the “Home Menu”, click “Setup”-->“Motor” to disable the motors so the motors/axis could be moved freely.

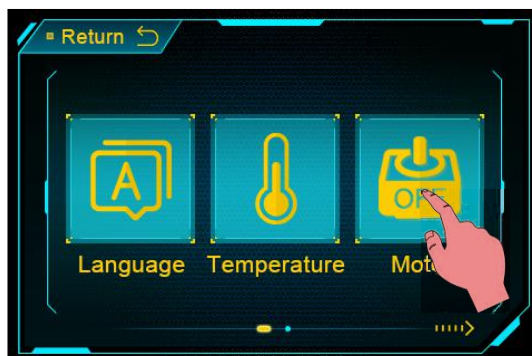

# Leveling

**Step 4.** Return to the “Home Menu”, click “Tools”-->“Home”-->“Home Z”. **Lock the Z axis to prevent the Z axis from falling during leveling.**

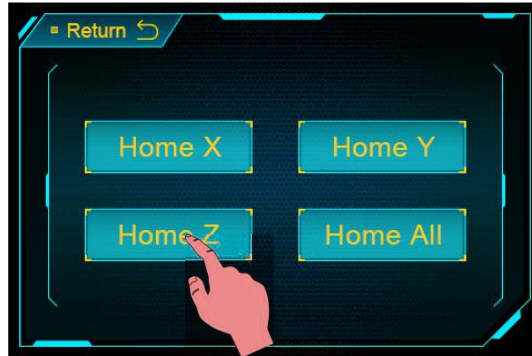

**Step 5.** As shown below, Put a leveling paper (average A4 paper) onto the print platform, and then manually move the print head back and forth to let the print head travel to 4 corners and center one by one (①→②→③→④→⑤). When nozzle has been moved to point ①, manually adjust (tighten or loose) the corresponding knob underneath the print platform.

**(Avoid nozzle rub against the platform directly without the paper in-between)**

Loosen the knob clockwise, the platform rises.  
Tighten the knob, the platform descends.

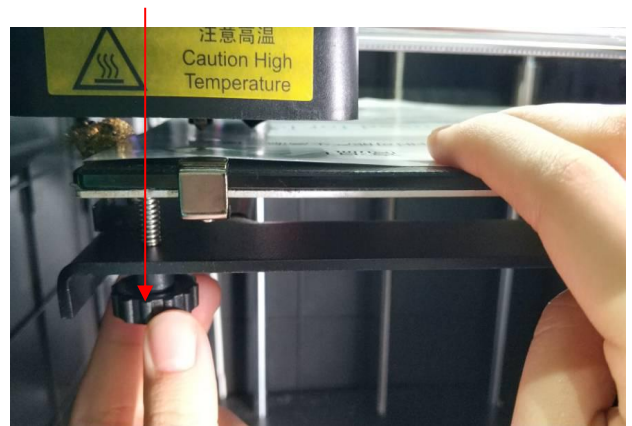
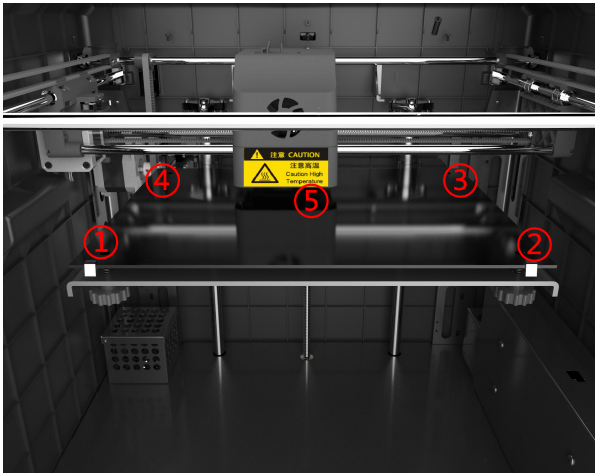

Leveling is to **adjust the distance between nozzle and print platform to about a piece of paper thin (~0.1-0.2mm)**. Therefore, when just feel the drag resistance as pulling the paper, it means good leveling for this particular point.

*(Note: “just feel the drag resistance” means the paper can be moved, but with resistance)*

Please do so to the rest points and the center spot.

# Leveling



Do the same operation at point ③ and point ④.

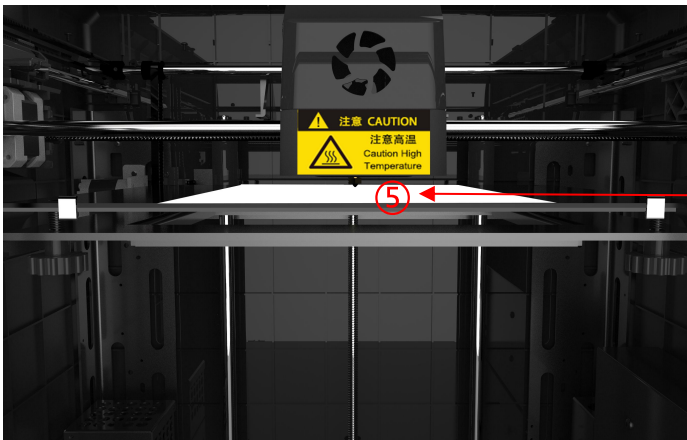

For point 5, adjust all the 4 nuts underneath until feeling the drag resistance as pulling the paper.

Perform double check to ensure the results, and **check the points in diagonal order: ①→③, ②→④.**

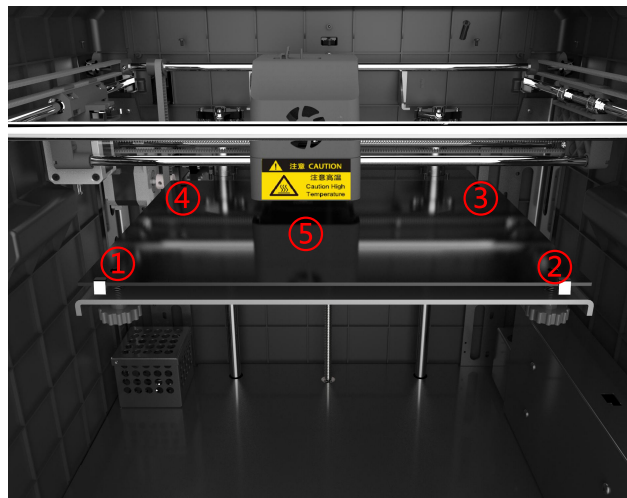

**Poor leveling will affect the print results, please be patient to level and verify the platform's 4 corners and center spot, so that the distance between nozzle and print platform is about a piece of paper thin (~0.1-0.2mm).**



# Leveling

## 2. Print test

Insert the memory card into the memory card slot. Click on the Home Menu “Print” to enter the file list. There is a printable test file included -- “owl\_pair” (author: etotheipi, [www.thingiverse.com](http://www.thingiverse.com)). Single click on “owl\_pair”, and click “Print”. The machine will be automatically heating the platform and nozzle before printing.

There might be 3 kinds of results for the first layer of the test prints

**A:** Lack of extrusion, the nozzle rub against the platform.



Nozzle too close

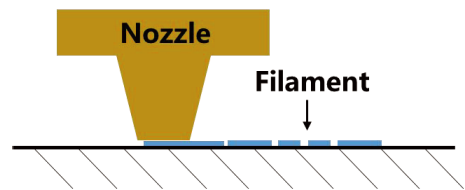

**B:** Good extrusion and adhesion



Proper nozzle height

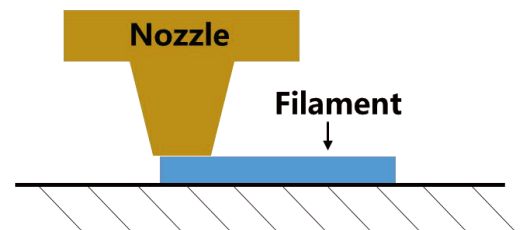

# Leveling

**C:** Large gap, filaments are not even adhere to the platform

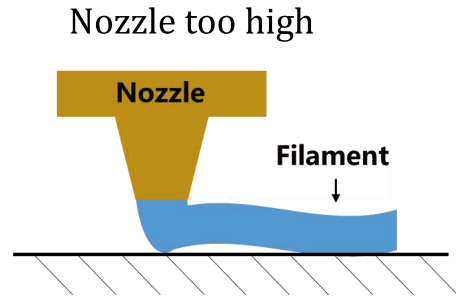
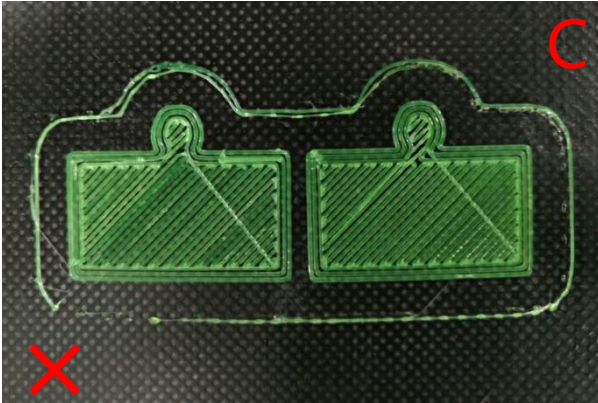

In case of “nozzle too close” or “nozzle too high”(A or C), please manually fine tune the corresponding nuts under the platform.

*It may need adjustment for few times until satisfying results such as B.*

**Note:** It is recommended leave the top open while print PLA filament, because PLA needs heat dissipation, opening the top cover could help improving the printing quality; On the other hand, for printing ABS filament, it is recommended to cover the top to maintain a relative high environment temperature, which helps improving the printing quality, and also keep the ABS odor inside the chamber.

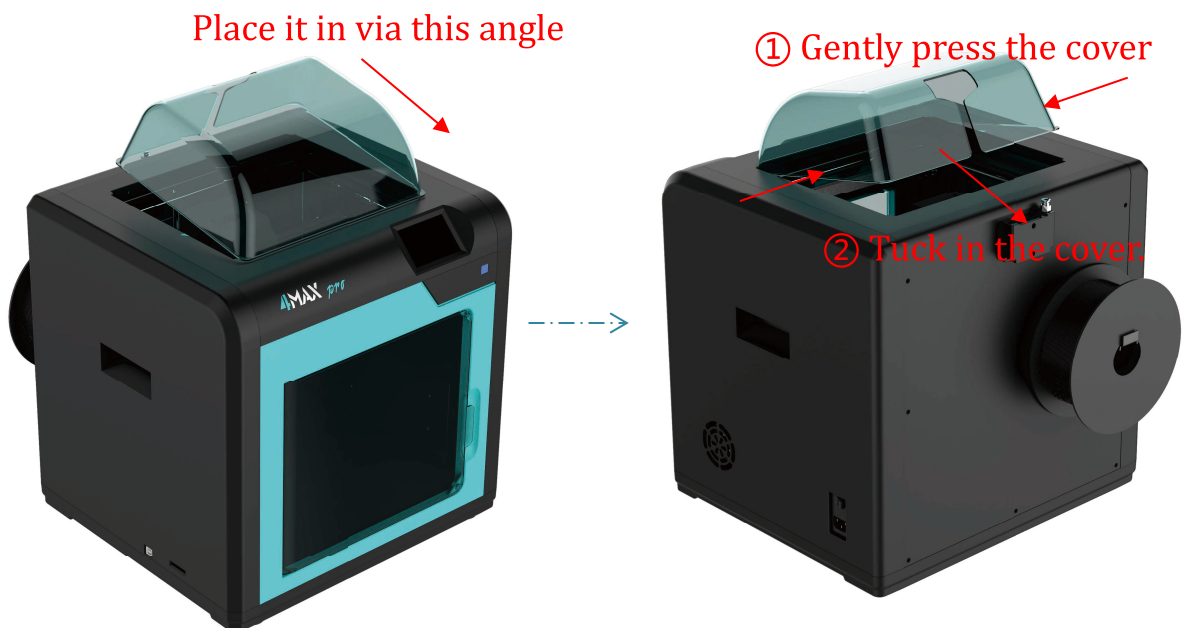

**How to install the cover**

# Driver installation

There are two operational mode for **ANYCUBIC** 4Max Pro : print offline and print online.

**Print offline:** As shown previously, after insert memory card, platform leveled, click “Print” on the display and print a selected file (GCode files ONLY).

**Print online:** Install CP2102 driver to bridging PC and machine, and install Cura for slicing and control the machine to print via data cable.

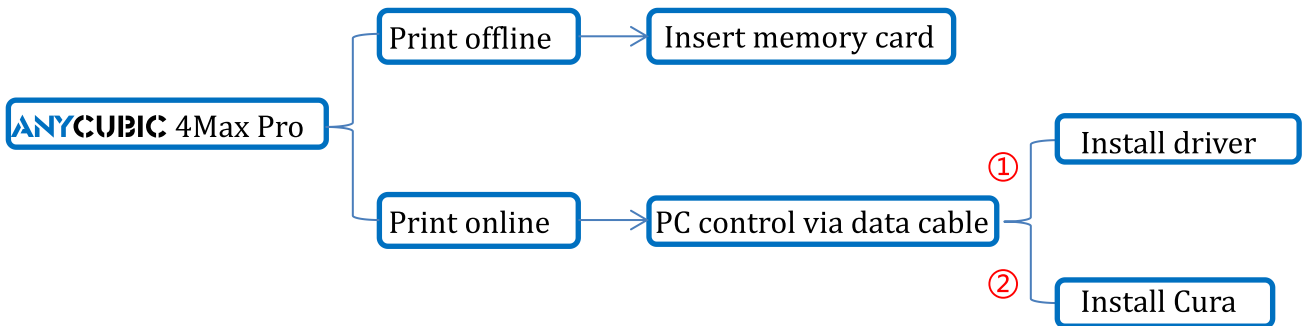

It is suggested to use **Print Offline** mode to minimize the noisy signal via data cable.

## How to install the software to enable PC control (print online).

First, turn on the machine, connect the printer (data cable port) and your PC via data cable. **ANYCUBIC** 4Max Pro uses CP2102 chip for communication. The CP2102 driver may not be installed automatically, so it is required to check that. Right click “This PC” → “Properties” → “Device manager”, if there is an exclamation mark as shown below, then it needs to be installed manually.

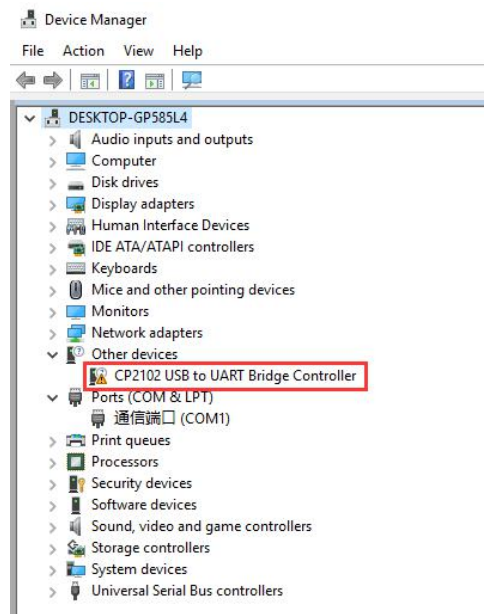

# Driver installation

CP2102 driver files are located in the memory card (or visit our website to download). “Files\_English\_4MAX PRO”→“Driver\_CP2102”→“Windows” (“CP210xVCPInstaller\_x64” is for 64 bit system and “CP210xVCPInstaller\_x86” is for 32 bit system). Here Windows 7 64 bit PC is taken for example:

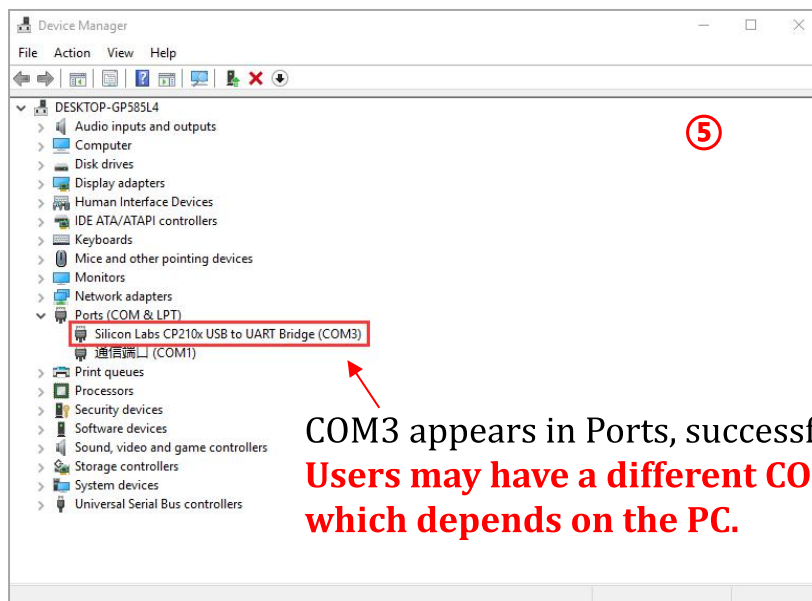
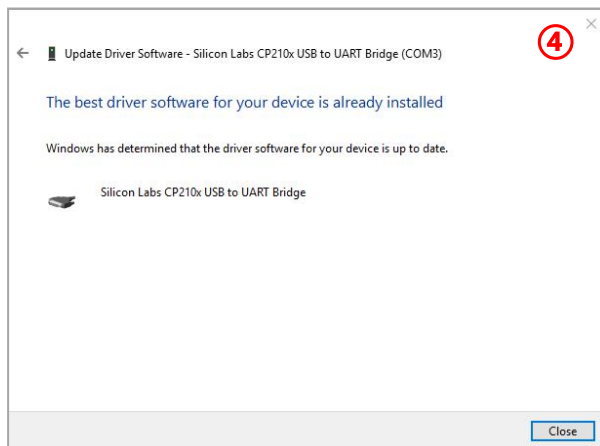
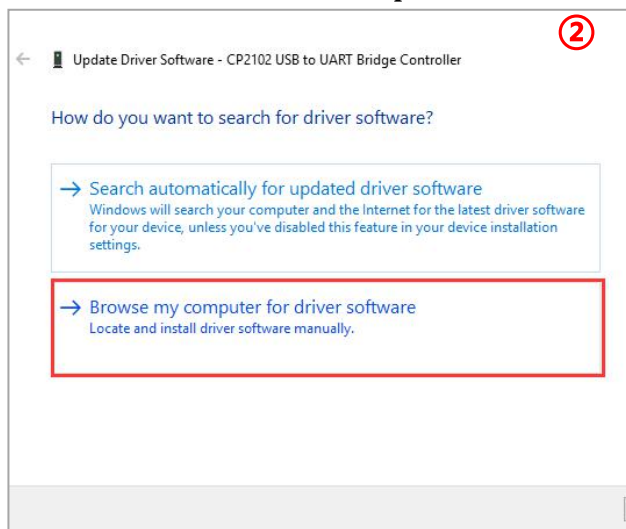
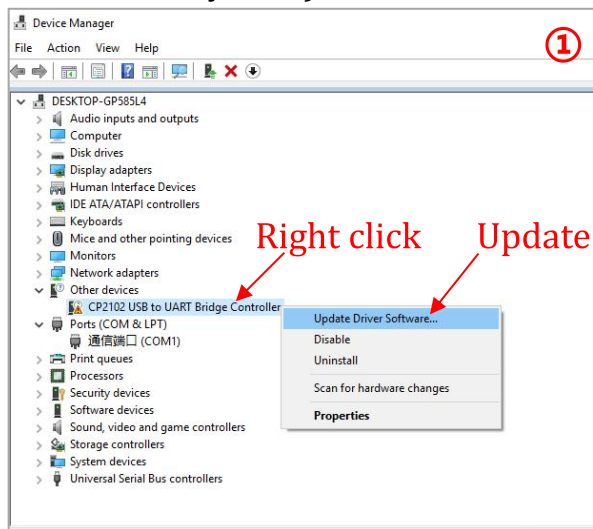



# Introduction to slicing software

Introduction of slicing software: ①Cura installation, ②Manipulate 3D model in Cura, ③Cura settings, ④Print online, ⑤ Print offline

## 1. Cura installation

Cura15.04.6 is used for example here (Users may use their own slicer software).

It is located in memory card→“ Files\_English\_4MAX PRO”→“ Cura”→

“ Windows”. Double click “Cura\_15.04.6”, and follow the steps as shown below.

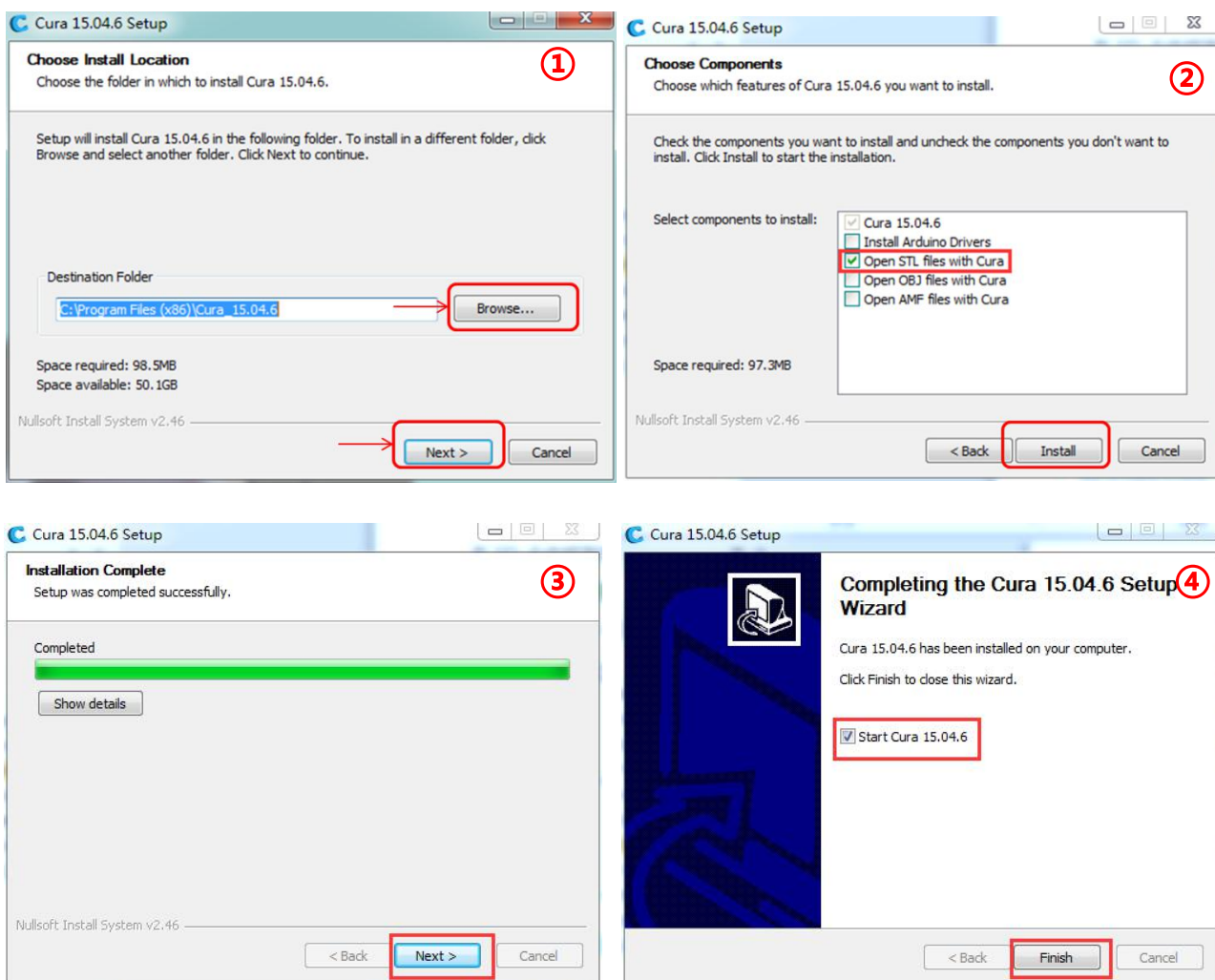

Next, before start Cura for the first time, there will be more settings about the language and machine types, as shown below:

# Introduction to slicing software

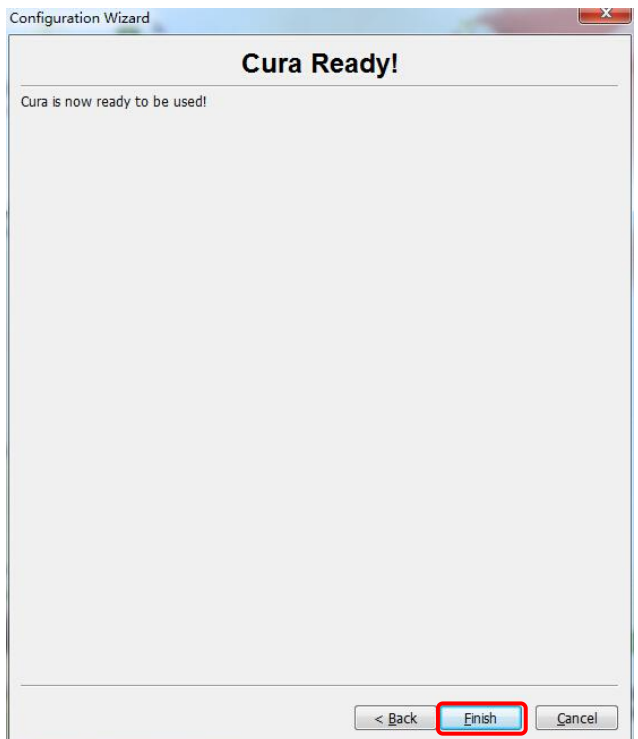
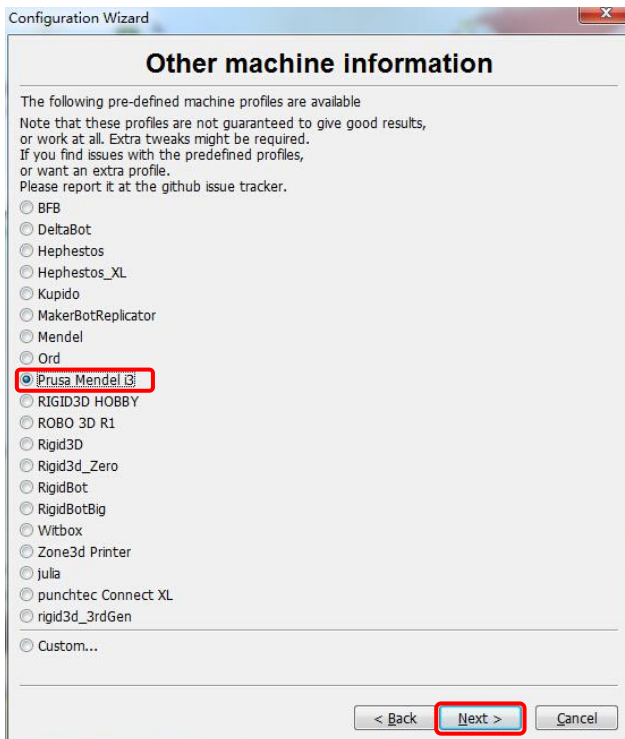
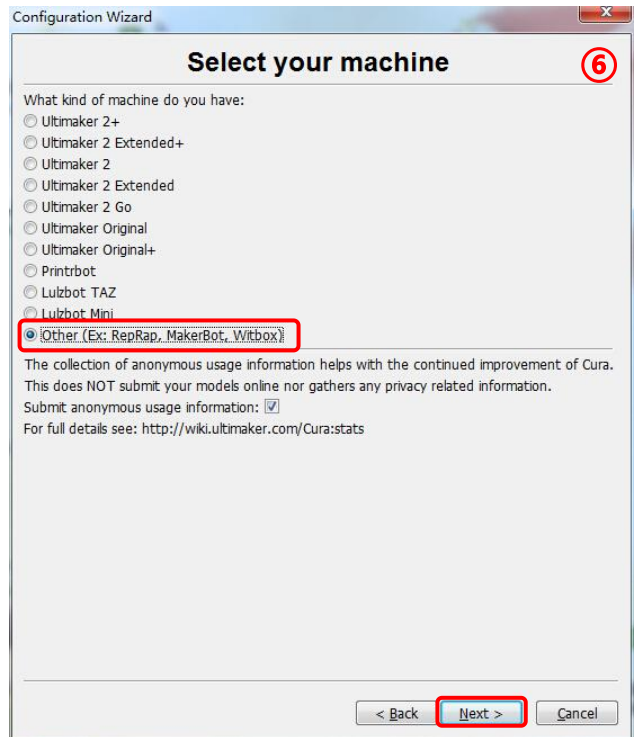

Upon finishing, open Cura for the first time, there might be a default robot model, customers may click “File”→ “Clear platform” to delete it.

# Introduction to slicing software

## 2. Manipulate 3D model in Cura

In the Cura software interface, click on the “File” → “Load model file” to import your own three-dimensional format model (such as .stl file). Users can “Rotate” “Scale” “Mirror” the model. As shown below:

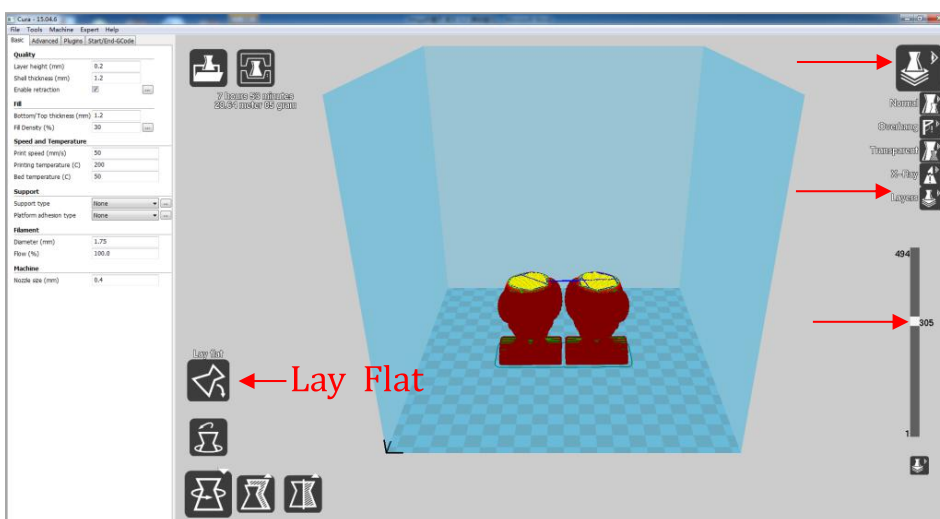
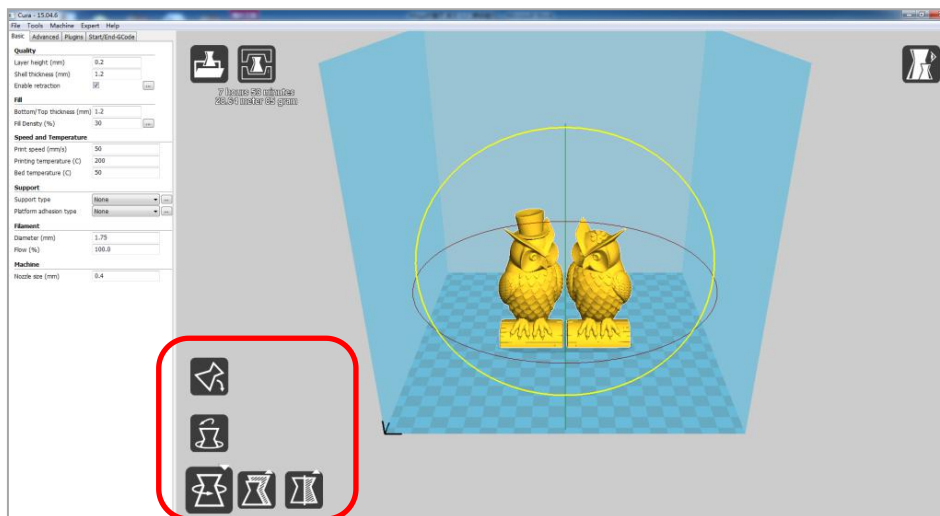

### Other operations:

- (1) Change viewing angle : right click the model, hold on and move the mouse.
- (2) Zoom in/out : scroll the mouse wheel.
- (3) Position change : left click on the model, hold on and drag the model to move.
- (4) After rotating the model, it is strongly recommended to click on the 'Lay Flat' icon to ensure that flat portion of the model is well attached to the platform.

# Introduction to slicing software

## 3. Cura settings

(1) In the menu bar, select “Machine” → “Machine settings”. Please choose the same Serial (COM) Port as shown in your PC → Device Manager → Port (customers may have a different COMx other than the example COM2 below).

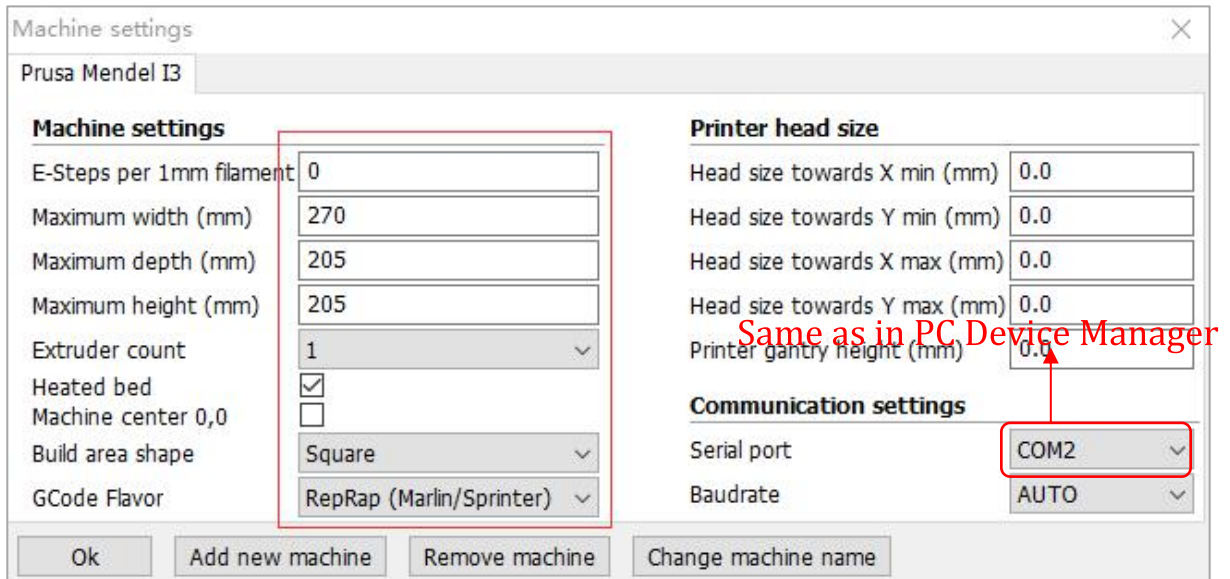

(2) Click “OK” for the settings to return to the main interface, and then set the “Basic” and “Advanced” parameters separately (For PLA filament), as shown below:

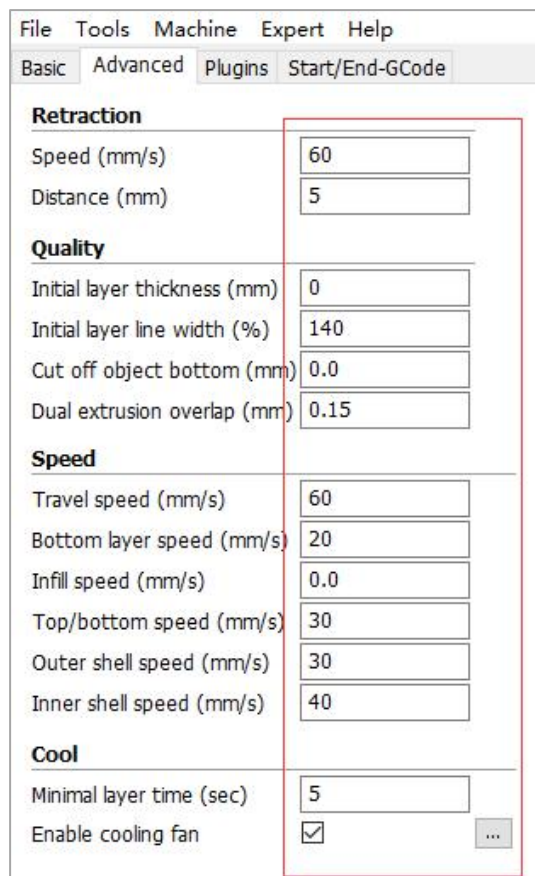
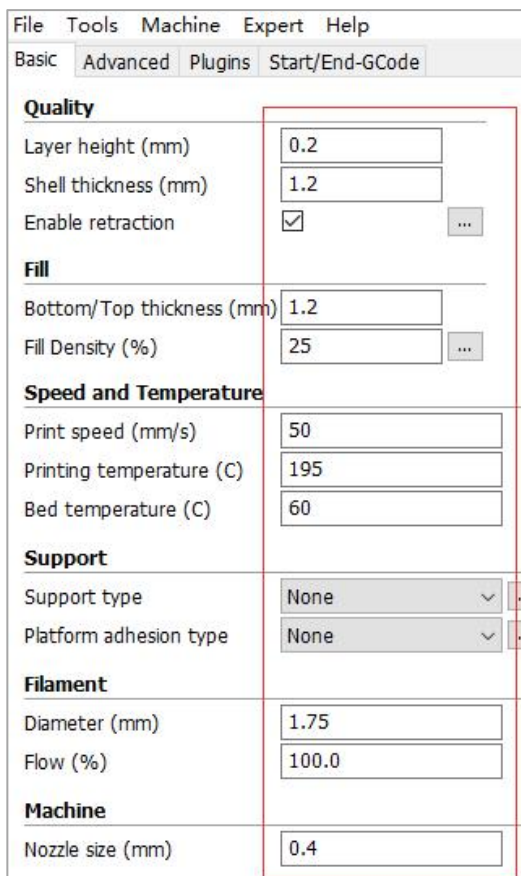

# Introduction to slicing software

(3) In the menu bar, select “Expert” → “Open expert settings ”, and then set the parameters separately, as shown below:

**Those parameters are just for example and reference, users may have to fine tune those parameters to gain the best printing results.**

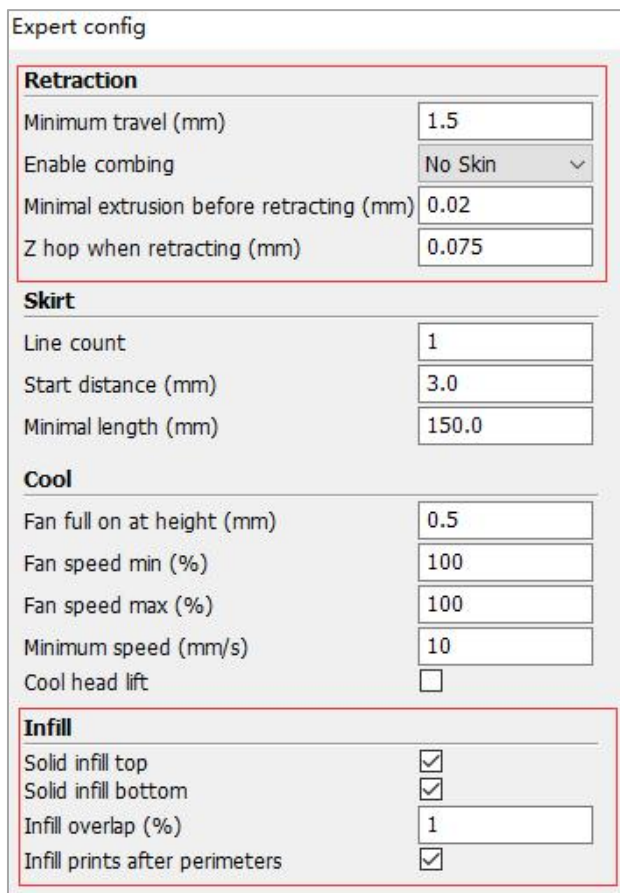
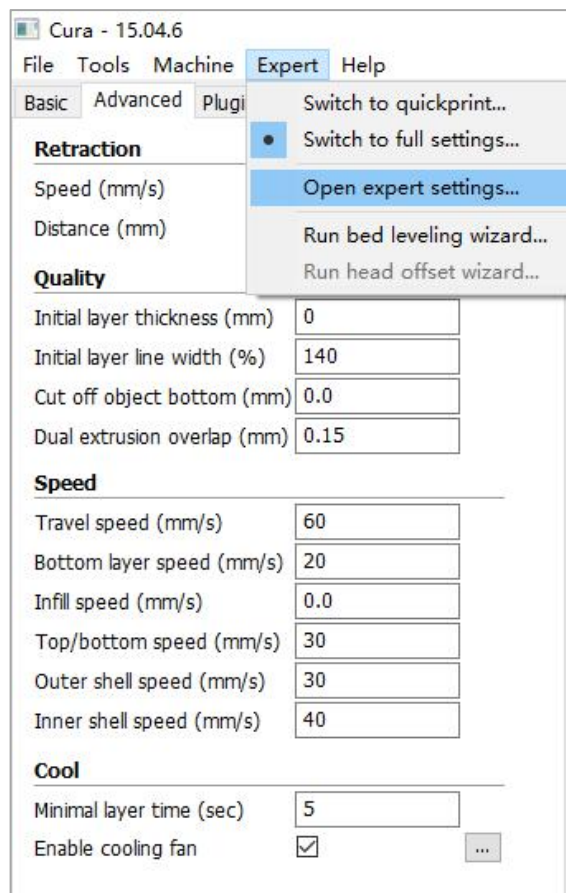



# Introduction to slicing software

4Max Pro is compatible with ABS filament, and we provide the settings as shown below (It is recommended to print in places with good air circulation)

File Tools Machine Expert Help	
Basic Advanced Plugins Start/End-GCode	
<b>Quality</b>	
Layer height (mm)	<input type="text" value="0.2"/>
Shell thickness (mm)	<input type="text" value="1.2"/>
Enable retraction	<input checked="" type="checkbox"/> ...
<b>Fill</b>	
Bottom/Top thickness (mm)	<input type="text" value="1.2"/>
Fill Density (%)	<input type="text" value="25"/> ...
<b>Speed and Temperature</b>	
Print speed (mm/s)	<input type="text" value="50"/>
Printing temperature (C)	<input type="text" value="240"/>
Bed temperature (C)	<input type="text" value="100"/>
<b>Support</b>	
Support type	None ▾ ...
Platform adhesion type	<b>Brim</b> ▾ ...
<b>Filament</b>	
Diameter (mm)	<input type="text" value="1.75"/>
Flow (%)	<input type="text" value="100.0"/>
<b>Machine</b>	
Nozzle size (mm)	<input type="text" value="0.4"/>

Add brim

File Tools Machine Expert Help	
Basic Advanced Plugins Start/End-GCode	
<b>Retraction</b>	
Speed (mm/s)	<input type="text" value="60"/>
Distance (mm)	<input type="text" value="5"/>
<b>Quality</b>	
Initial layer thickness (mm)	<input type="text" value="0"/>
Initial layer line width (%)	<input type="text" value="140"/>
Cut off object bottom (mm)	<input type="text" value="0.0"/>
Dual extrusion overlap (mm)	<input type="text" value="0.15"/>
<b>Speed</b>	
Travel speed (mm/s)	<input type="text" value="60"/>
Bottom layer speed (mm/s)	<input type="text" value="20"/>
Infill speed (mm/s)	<input type="text" value="0.0"/>
Top/bottom speed (mm/s)	<input type="text" value="30"/>
Outer shell speed (mm/s)	<input type="text" value="30"/>
Inner shell speed (mm/s)	<input type="text" value="40"/>
<b>Cool</b>	
Minimal layer time (sec)	<input type="text" value="5"/>
Enable cooling fan	<input type="checkbox"/> ...

Disable cooling fan

In the menu bar, select “Expert” → “Open expert settings”, and then set the parameters separately, as shown below:

# Introduction to slicing software

Cura - 15.04.6

File Tools Machine Expert Help

Basic Advanced Plugi Switch to quickprint...  
Switch to full settings...  
Open expert settings...  
Run bed leveling wizard...  
Run head offset wizard...

**Retraction**

Speed (mm/s)

Distance (mm)

**Quality**

Initial layer thickness (mm) 0

Initial layer line width (%) 140

Cut off object bottom (mm) 0.0

Dual extrusion overlap (mm) 0.15

**Speed**

Travel speed (mm/s) 60

Bottom layer speed (mm/s) 20

Infill speed (mm/s) 0.0

Top/bottom speed (mm/s) 30

Outer shell speed (mm/s) 30

Inner shell speed (mm/s) 40

**Cool**

Minimal layer time (sec) 5

Enable cooling fan

Expert config

**Retraction**

Minimum travel (mm) 1.5

Enable combing No Skin

Minimal extrusion before retracting (mm) 0.02

Z hop when retracting (mm) 0.075

**Skirt**

Line count 1

Start distance (mm) 3.0

Minimal length (mm) 150.0

**Cool**

Fan full on at height (mm) 0.5

Fan speed min (%) 100

Fan speed max (%) 100

Minimum speed (mm/s) 10

Cool head lift

**Infill**

Solid infill top

Solid infill bottom

Infill overlap (%) 1

Infill prints after perimeters

When setting the parameters of ABS filament, adding birm and disabling cooling fan helps the filament adhere the platform.

# Introduction to slicing software

4Max Pro is compatible with flexible filament, and we provide the settings as shown below if using **ANYCUBIC** flexible filaments (**users may have to fine-tune the settings based on the actual printing conditions, and type of filaments, etc.**).

File Tools Machine Expert Help	
Basic Advanced Plugins Start/End-GCode	
<b>Quality</b>	
Layer height (mm)	<input type="text" value="0.2"/>
Shell thickness (mm)	<input type="text" value="1.2"/>
Enable retraction	<input checked="" type="checkbox"/> ...
<b>Fill</b>	
Bottom/Top thickness (mm)	<input type="text" value="1.2"/>
Fill Density (%)	<input type="text" value="25"/> ...
<b>Speed and Temperature</b>	
Print speed (mm/s)	<input type="text" value="50"/>
Printing temperature (C)	<input type="text" value="195"/>
Bed temperature (C)	<input type="text" value="60"/>
<b>Support</b>	
Support type	None ▾ ...
Platform adhesion type	None ▾ ...
<b>Filament</b>	
Diameter (mm)	<input type="text" value="1.75"/>
Flow (%)	<input type="text" value="100.0"/>
<b>Machine</b>	
Nozzle size (mm)	<input type="text" value="0.4"/>

File Tools Machine Expert Help	
Basic Advanced Plugins Start/End-GCode	
<b>Retraction</b>	
Speed (mm/s)	<input type="text" value="60"/>
Distance (mm)	<input type="text" value="8"/>
<b>Quality</b>	
Initial layer thickness (mm)	<input type="text" value="0"/>
Initial layer line width (%)	<input type="text" value="140"/>
Cut off object bottom (mm)	<input type="text" value="0.0"/>
Dual extrusion overlap (mm)	<input type="text" value="0.15"/>
<b>Speed</b>	
Travel speed (mm/s)	<input type="text" value="60"/>
Bottom layer speed (mm/s)	<input type="text" value="20"/>
Infill speed (mm/s)	<input type="text" value="0.0"/>
Top/bottom speed (mm/s)	<input type="text" value="30"/>
Outer shell speed (mm/s)	<input type="text" value="30"/>
Inner shell speed (mm/s)	<input type="text" value="40"/>
<b>Cool</b>	
Minimal layer time (sec)	<input type="text" value="5"/>
Enable cooling fan	<input checked="" type="checkbox"/> ...

In the menu bar, select “Expert” → “Open expert settings”, and then set the parameters separately, as shown below:



# Introduction to slicing software

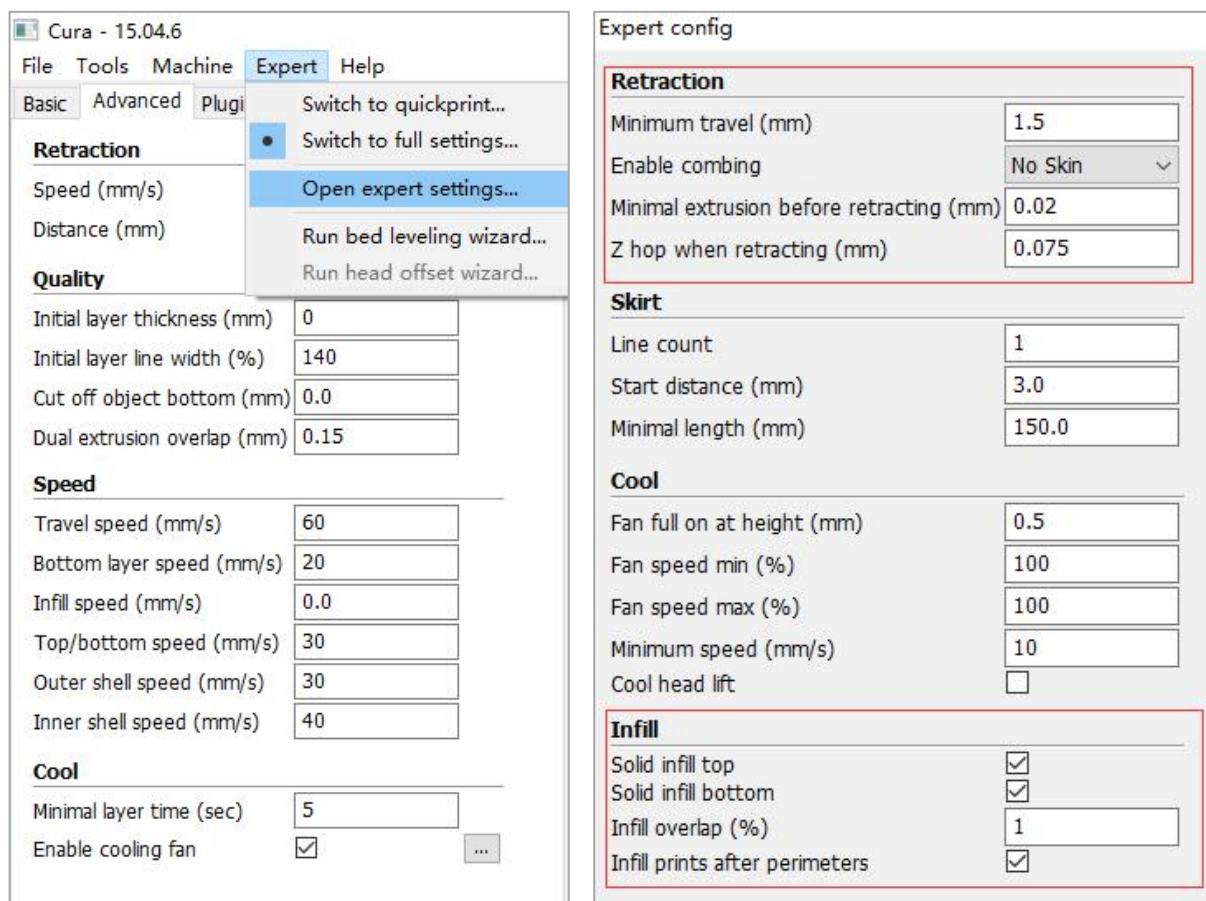

## Explanation:

**Layer height:** determine the important parameters for print quality, usually set to 0.1-0.3.

**Shell thickness:** usually set to a multiple of the nozzle diameter.

**Fill density:** The larger the parameter, the more solid the model is.

**Print speed:** printing too fast may make printer shaky, 30-60 is suggested.

**Printing temperature:** PLA should be 190-210°C, ABS should be 230-240°C, and TPU should be 190-220 °C .

**Filament diameter:** 1.75mm.

**Nozzle size:** 0.4mm.

**Retraction speed:** Increasing the retraction speed and distance can reduce the stringing problem, but set it too high may cause clogging.

**Travel speed:** 60mm/s is suggested, the printing accuracy would be affected if it is too fast.

**Outer shell speed:** Reducing the outer shell print speed would create a more smooth model surface.

# Introduction to slicing software

## 4. Print online

After the parameters have been set up, you can print online via Cura. As shown below, click on the upper left corner “File” → “Print”, Cura will automatically connect to the printer. The user can click “Print” icon when it is available. Then the temperature would rise and it will start to print when reaching to the target temperature. Use tweezers to carefully get rid of the pre-extruded filament at the nozzle tip.

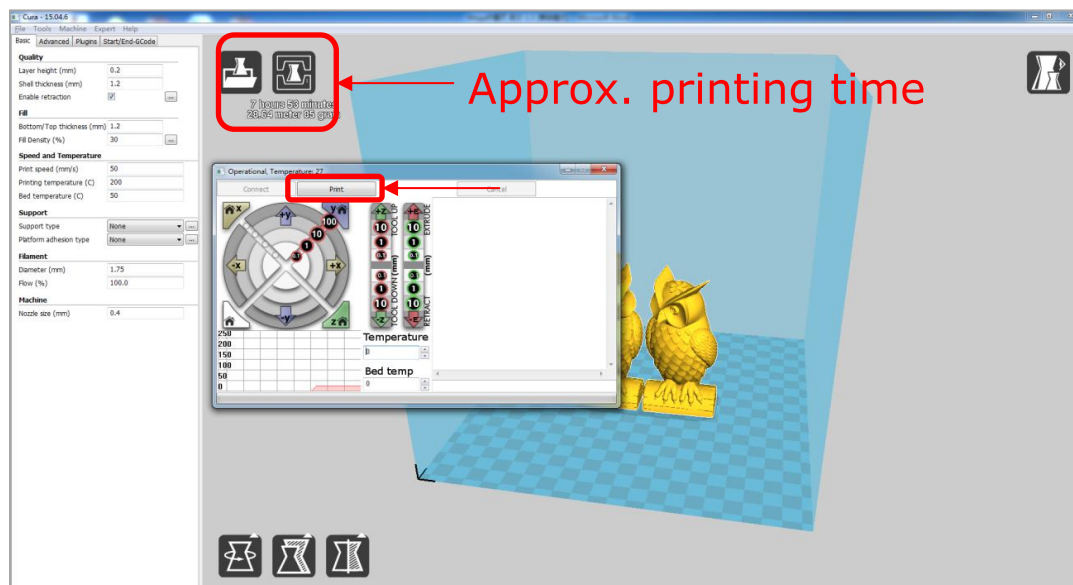

## 5. Print offline

After completing all the parameter settings, click on the Cura software main interface “File” → “Save GCode”. Save the model GCode file to the **memory card**, and then insert the memory card to the printer and control via the touch screen for offline printing.

**Note:** the file name should only contain English letters, underscore and space. File name contains special characters could not be recognized by the printer.

# Introduction to filament sensor

1. **ANYCUBIC** 4Max Pro alarms when filament break during an ongoing print, the interface shown below will be popped up.

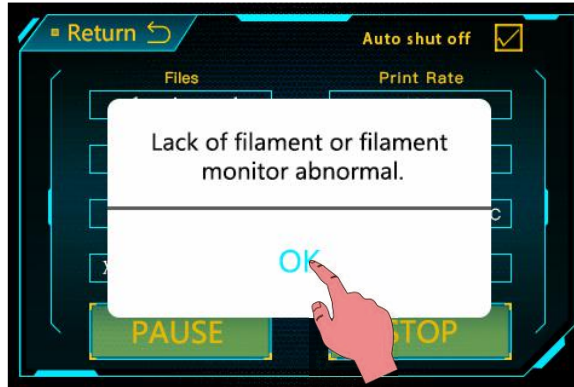

2. Click “OK”, remove the remaining filaments and re-installing new filaments.

**Remove the remaining filaments:** pull out the teflon feeding tube, then press the handle on the extruder and firstly push the filament in till the filament is just melted through the nozzle, then pull it out quickly.

**Re-install new filaments:** see page 14 “Install filament”.

3. After the filaments re-installed, use tweezers to clean the filament residue on nozzle tip. Then click “CONTINUE”, the print will start again from the last position.

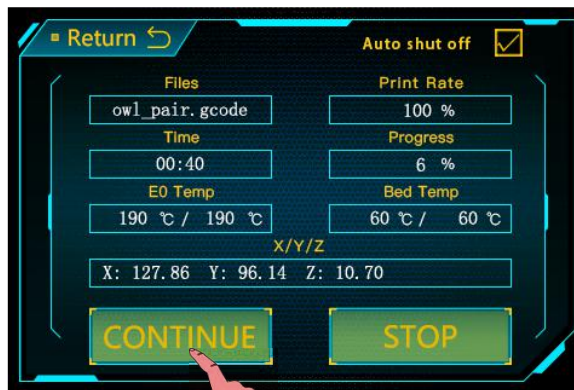

# Introduction to nozzle brush

The nozzle would pass through the nozzle brush when home, which helps to clean the nozzle tip.

For the first time of using the nozzle brush, users are required to add the bottom right code (gray) to the start.gcode in Slicing Software (Cura here for example), as shown below.

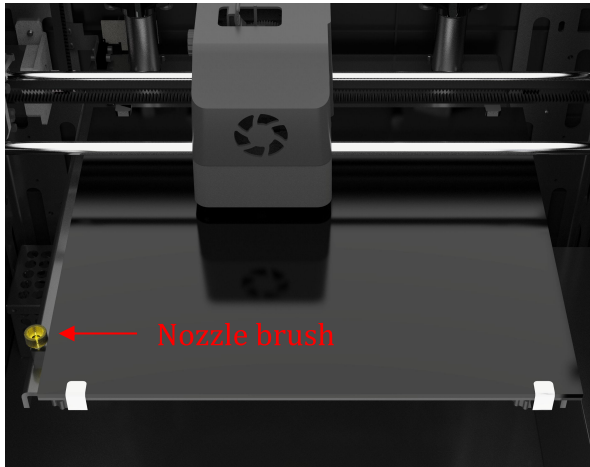

```
File Tools Machine Expert Help
Basic Advanced Plugins Start/End-GCode
start.gcode
end.gcode

;Sliced at: {day} {date} {time}
;Basic settings: Layer height: {la
;Print time: {print_time}
;Filament used: {filament_amount}m
;Filament cost: {filament_cost}
;M190 S{print_bed_temperature} ;Un
;M109 S{print_temperature} ;Uncomm
G21 ;metric values
G90 ;absolute positioning
M82 ;set extruder to absolu
M107 ;start with the fan off
G28 X0 Y0 ;move X/Y to min endstop
G28 Z0 ;move Z to min endstops
G1 X-3 Y40
G1 X-3 Y5
G1 X-3 Y40
G1 X-3 Y5
G1 Z15.0 F{travel_speed} ;move the
G92 E0 ;zero the
G1 F200 E3 ;extrude 3
G92 E0 ;zero the
G1 F{travel_speed}
;Put printing message on LCD screen
M117 Printing...
```

# Resume from outage

**ANYCUBIC 4Max Pro** allows resume print after accidentally power outage (**This function only valid when print offline, via memory card only**).

1. As shown in Fig.(1)(2) , in slicing software (i.e. Cura), it is required to place the model at the rear of the platform. Because during “RESUME”, machine will home first and could touch/interfere with the unfinished object if the model was placed in the front area.

2. For the first time of using this function, users are required to add “G5” to the start.gcode, as shown in Fig. (3). Then, save the model as GCode file to the memory card by “File” → “Save GCode”.

**Note:** ① “Resume from outage” is valid only for offline printing;

② Just type the “G5” when you use it for the first time, G5 will be automatically added later, without having to manually type it again.

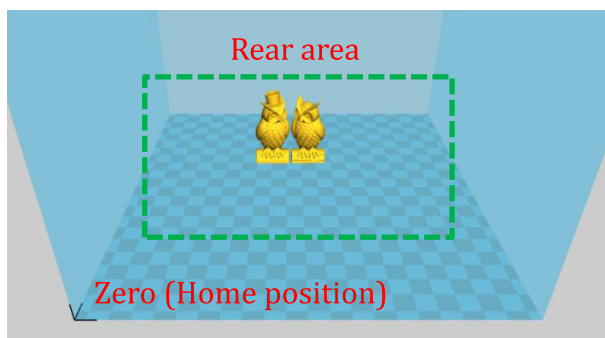

(1)

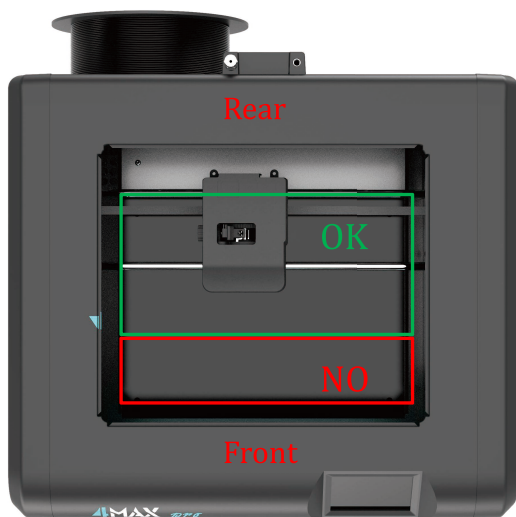

(2)

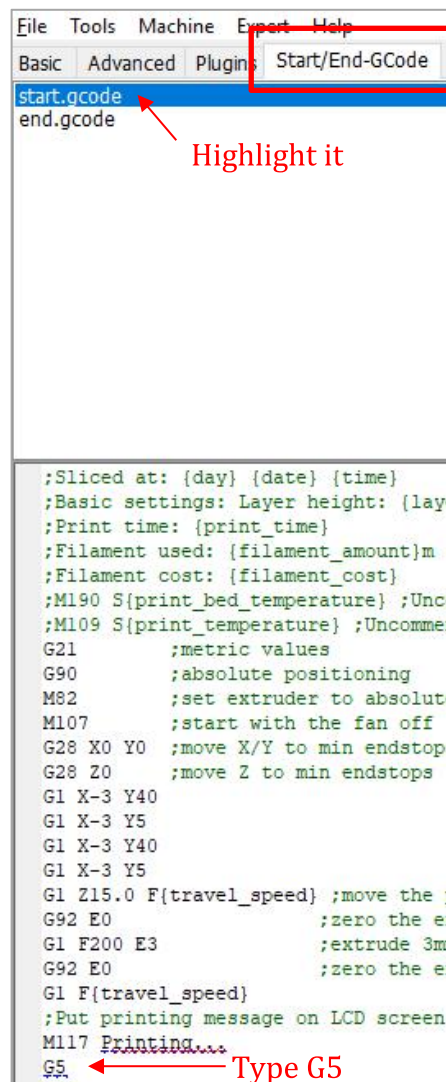

(3)



## Resume from outage

3. During printing, if there is an accident power loss, the print will stop immediately. But after power comes back, customers could choose “Print” → select the unfinished file → “RESUME”, machine will home first and continuing on the unfinished object.

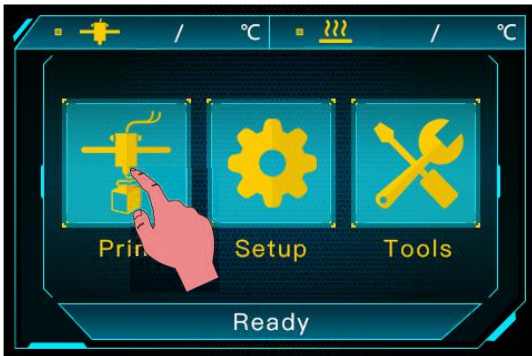

### Note:

- ① In order to get smooth surface, use tweezers to carefully remove the excessive filament at nozzle before continuing print upon the last point.
- ② Do not move Z axis after power off otherwise resume will be invalid.
- ③ **ANYCUBIC** 4Max Pro supports resume from outage only when print offline
- ④ This function is developed based on Cura. We could not guarantee this function compatible with other slicing software.
- ⑤ Due to the differences of models, filaments, temperature, extrusion settings, etc...we could not always guarantee a perfect surface finish at the point of “RESUME”, especially for small objects.



# Troubleshooting

## 1. Motor shaking or abnormal sound

- ① The corresponding end stop could not be triggered when home, check the wirings, and inspect any obstacles by manually moving the corresponding axis
- ② The motor cable are not connected properly, check each connection and then inspect the cable routing for any faults
- ③ The motor is damaged.
- ④ The motor driving wheel is loose.
- ⑤ The belt is loose, please check the belt tension at each position of X/Y/Z. And whether the belt is slippery during motor movement or not.

## 2. File not printing or memory card failure

- ① Remove the memory card and insert into PC. Open the GCode files using text editor (eg. Notepad), and inspect if GCode is readable or not. If files contains of multiple “ÿÿÿ” symbol, then file has been corrupted. Try reformatting the memory card to FAT32 format and reloading the GCode file
- ② Memory card is not readable, ensure file name does not contain special characters or Change memory card
- ③ Touch screen freeze, reboot the machine and try again

## 3. No extrusion or extrusion motor knocking

- ① Ensure that the nozzle temperature has been set to match the filament
- ② Filament tangled on spool
- ③ Not enough cooling for the hotend
- ④ Nozzle clogged please try to replace it or clean it with the nozzle cleaning needles
- ⑤ Teflon tubing has been tangled, squeezed or bent

## 4. Filament leaking

Nozzle or throat tube is not tightened properly, try to fix/change it after cooling

## 5. Layer shifting

- ① Print head moving too fast, slow down the print speed.
- ② Check the belts and driving wheels and ensure they are properly installed.
- ③ Grease the rods and check all nuts and bolts remain tightened.

# Troubleshooting

## 6. The print head falls during the printing process, scratch the platform or crush the model

① please remove the plastic cover of the print head and check whether the screws attached to the print head are loose (please consult customer service for more details)

## 7. No sticking to the bed

① The nozzle is too far from the platform, please try to re-level; at the same time set the "initial layer thickness" to 0 in Cura, and set the "initial layer line width" (for example, set to 150) to improve the first layer adhesion.

② Print too fast at the bottom layer speed, reduce it to ~20mm/s

③ Ensure that the print platform is clean (use alcohol if necessary)

④ Add a brim or raft to the model in slicing software

## 8. Freezing screen

① Please check if the soft cable above the screen is loose (you need to open the plastic base to check if the screen cable is loose)

① Inspect if the touch screen has been pressed by something

② Check if screen has cracks, if so, please contact our after sale service via official website [www.anycubic.com](http://www.anycubic.com)

## 9. T0 sensor abnormal

① Check the wiring of the hotend and ensure a good connection

② Check if there is any pins bent inside the connector

## 10. Print head move abnormal

① Check if choosing the right machine type in slicing software

② Check if any plugins in the slicing software

**11. When leveling, if the adjustable nut is completely loose (tightened), the platform is still far away (near) from the print head, this time you need to adjust the Z end stop up (down).**

## 12. Print stopped halfway

- ① Check if the GCode file is corrupted
- ② Delete plugins in the GCode file
- ③ Use print offline mode (memory card) instead of print online via data cable
- ④ The quality of the memory card is unstable. Try changing another brand memory card.
- ⑤ The power supply voltage is unstable. Please print again when the voltage is stable.

Thank you for purchasing **ANYCUBIC** products! Under normal usage and service, the products and its parts have a warranty period up to one year. Please visit **ANYCUBIC** official website ([www.anycubic.com](http://www.anycubic.com)) for more details and report any issues with **ANYCUBIC** products. Our professional after-sale service team would response within 24 hours and help you to solve the issue.





FOT034